

Responder LE Quick Reference Wiring Guide

For additional information, please see the Install Guide

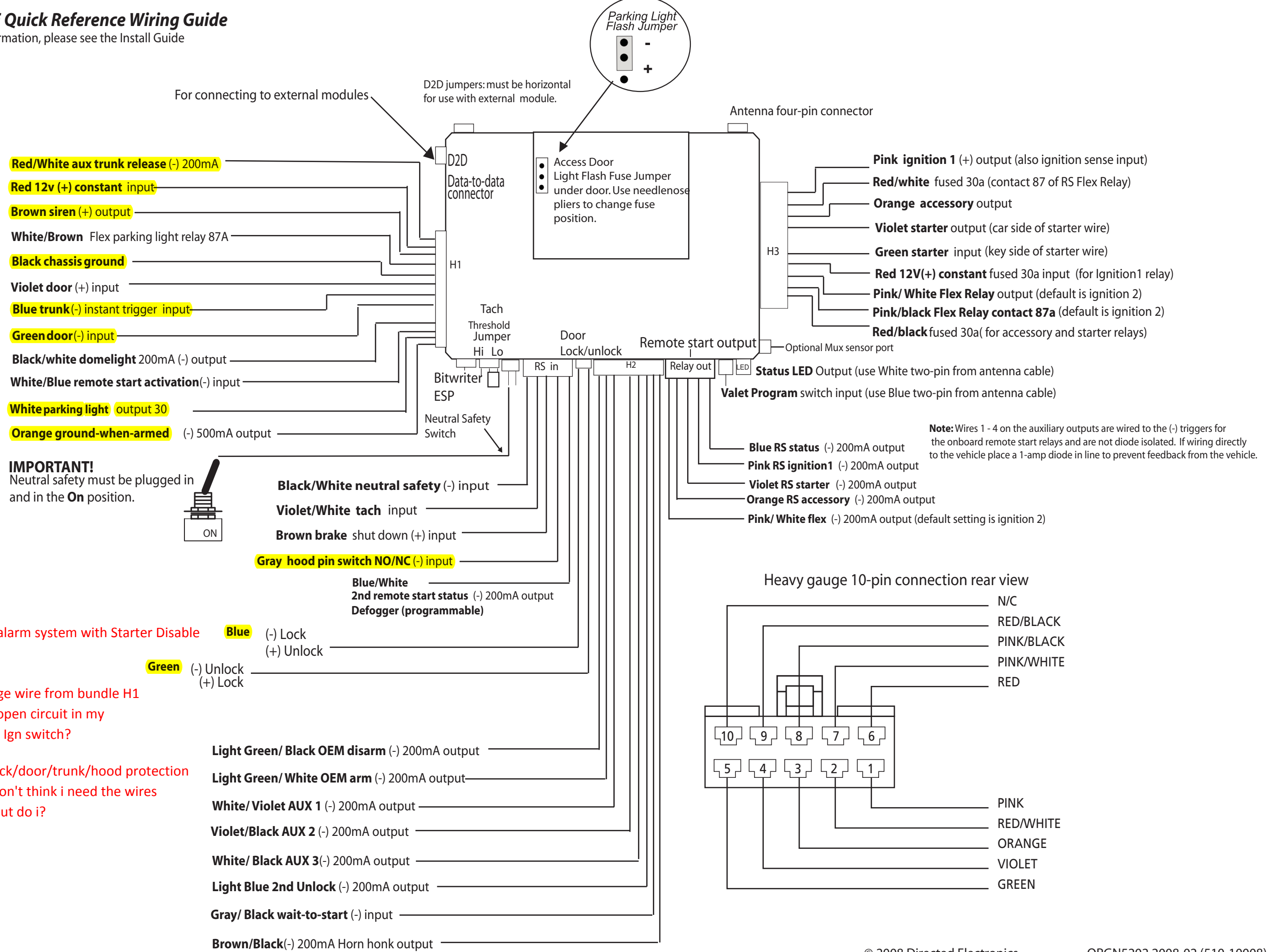

- Red/White aux trunk release (-) 200mA**
- Red 12v (+) constant input**
- Brown siren (+) output**
- White/Brown Flex parking light relay 87A**
- Black chassis ground**
- Violet door (+) input**
- Blue trunk(-) instant trigger input**
- Green door(-) input**
- Black/white domelight 200mA (-) output**
- White/Blue remote start activation(-) input**
- White parking light output 30**
- Orange ground-when-armed (-) 500mA output**

IMPORTANT!
Neutral safety must be plugged in and in the **On** position.

- Black/White neutral safety (-) input**
- Violet/White tach input**
- Brown brake shut down (+) input**
- Gray hood pin switch NO/NC (-) input**
- Blue/White 2nd remote start status (-) 200mA output Defogger (programmable)**
- Blue (-) Lock (+) Unlock**
- Green (-) Unlock (+) Lock**
- Light Green/ Black OEM disarm (-) 200mA output**
- Light Green/ White OEM arm (-) 200mA output**
- White/ Violet AUX 1 (-) 200mA output**
- Violet/Black AUX 2 (-) 200mA output**
- White/ Black AUX 3(-) 200mA output**
- Light Blue 2nd Unlock (-) 200mA output**
- Gray/ Black wait-to-start (-) input**
- Brown/Black(-) 200mA Horn honk output**

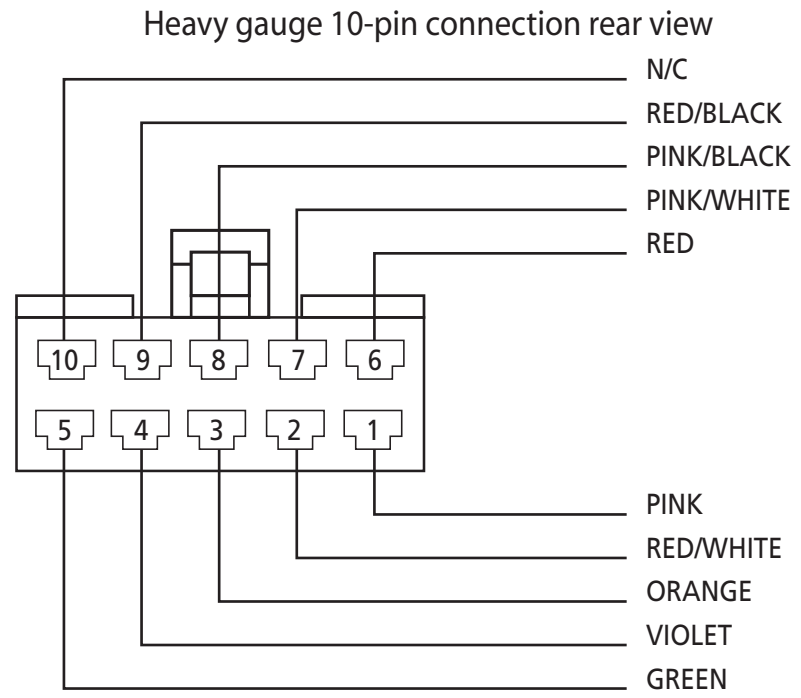

Goal is to have a basic alarm system with Starter Disable but no Remote Start.

Can I just use the Orange wire from bundle H1 to a relay to create an open circuit in my starter output from my Ign switch?

Basically only want shock/door/trunk/hood protection with starter disable, I don't think i need the wires in bundle H3 or Relay out do i?