

REMOVAL STEPS (Continued)

- ENGINE FRONT MOUNTING BRACKET (REFER TO GROUP 32, ENGINE MOUNT P.32-3.)
- >>G<< • VALVE TIMING BELT TENSION ADJUSTMENT
- <<A>> >>F<< 6. VALVE TIMING BELT
- >>E<< 7. TIMING BELT TENSIONER PULLEY
- 8. TIMING BELT TENSIONER ARM
- >>D<< 9. TIMING BELT TENSIONER ADJUSTER

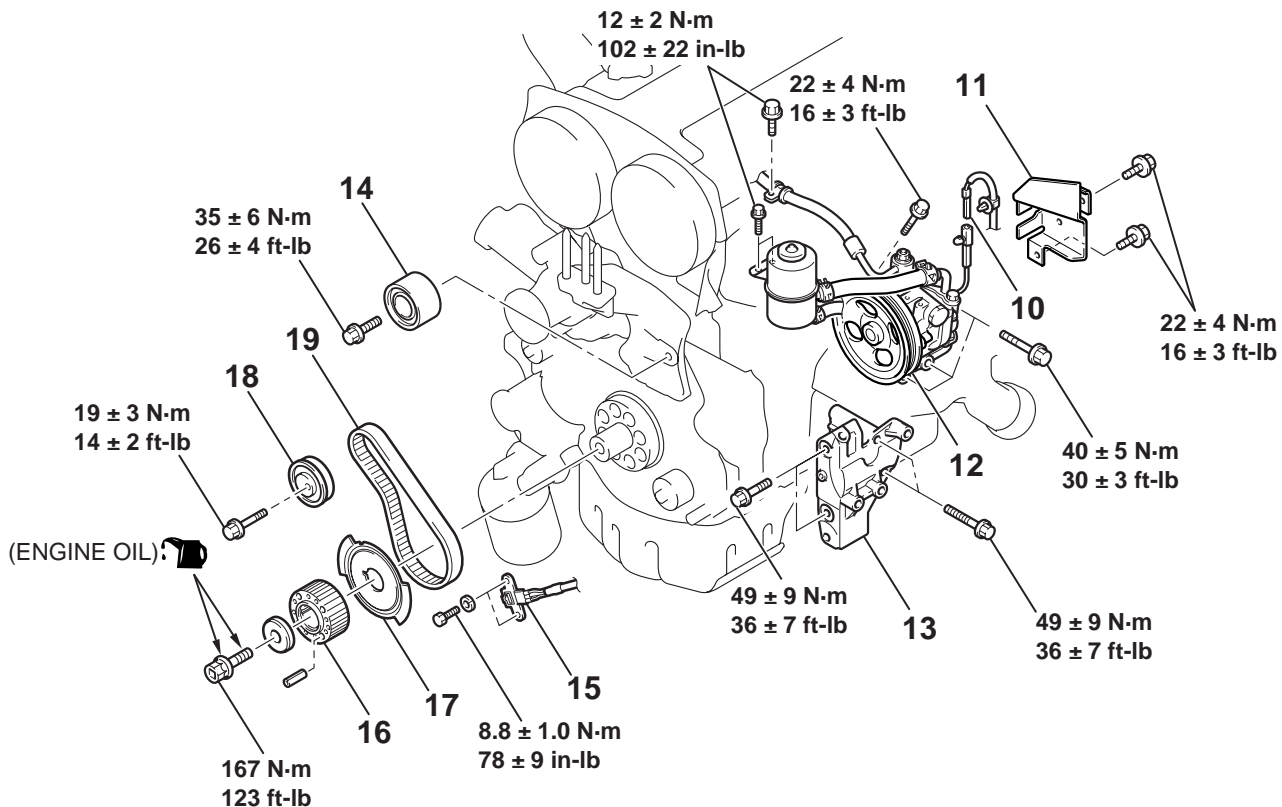

AC211076AB

REMOVAL STEPS

- 10. POWER STEERING PRESSURE SWITCH CONNECTOR
- 11. POWER STEERING OIL PUMP HEAT PROTECTOR
- <> 12. POWER STEERING OIL PUMP, BRACKET AND RESERVOIR ASSEMBLY
- 13. POWER STEERING OIL PUMP BRACKET
- 14. TIMING BELT IDLER PULLEY

REMOVAL STEPS (Continued)

- 15. CRANKSHAFT POSITION SENSOR
- <<C>> >>C<< 16. CRANKSHAFT CAMSHAFT DRIVE SPROCKET
- >>C<< 17. CRANKSHAFT ANGLE SENSING BLADE
- >>B<< • BALANCER TIMING BELT TENSION ADJUSTMENT
- >>A<< 18. BALANCER TIMING BELT TENSIONER
- <<D>> >>A<< 19. BALANCER TIMING BELT

Required Special Tools:

- MB991367: Special Spanner
- MB991385: Pin
- MD998738: Adjusting Bolt
- MD998767: Tensioner Wrench