

>>F<< VALVE TIMING BELT INSTALLATION

1. Align the timing marks on the camshaft sprocket, crankshaft camshaft drive sprocket and engine oil pump sprocket.

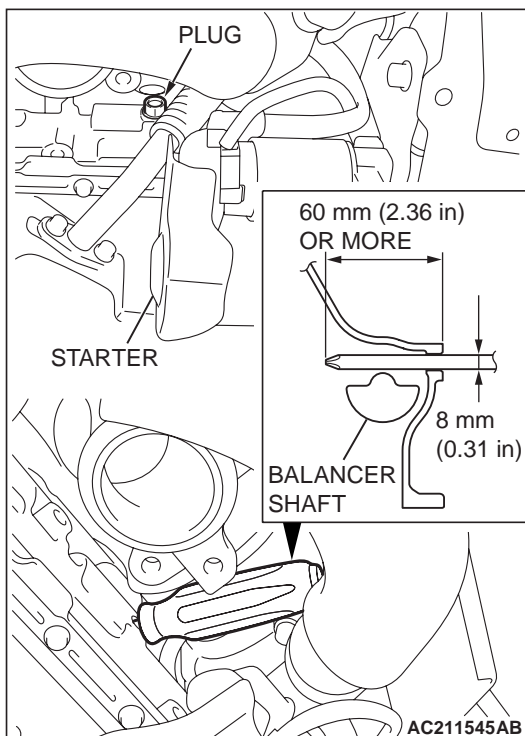
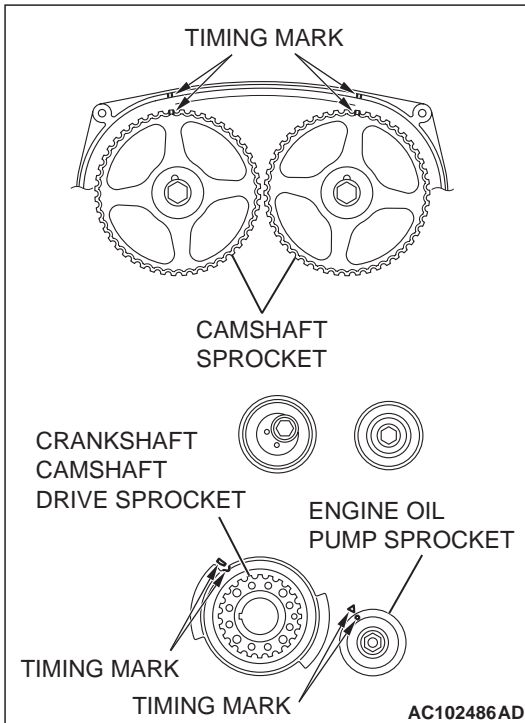

2. After aligning the timing marks of the engine oil pump sprocket, remove the cylinder block plug and insert a Phillips screw driver with a shaft diameter of 8 mm (0.31 inch) through the plug hole to check that the shaft of the screw driver can be inserted for 60 mm (2.36 inches) or more. If the screw driver makes contact with the balancer shaft and can be inserted for only 20 – 25 mm (0.79 – 0.98 inch), turn the engine oil pump sprocket for one round and align timing marks again to check that screw driver can be inserted for 60 mm or more. Do not take the screw driver out before completing installation of the valve timing belt.
3. Install the valve timing belt as follows: