

If the projection of timing belt tensioner adjuster rod is within the standard value, appropriate tension is applied.

Standard value (A): 3.8 – 4.5 mm (0.15 – 0.17 inch)

11. If wire or pin cannot be easily pulled out, repeat Step 1 through Step 9 to reach proper valve timing belt tension.

CAUTION

Always check the tightening torque of the crank shaft pulley center bolt when turning the crack shaft pulley center bolt counterclockwise. Re-tighten if it is loose.

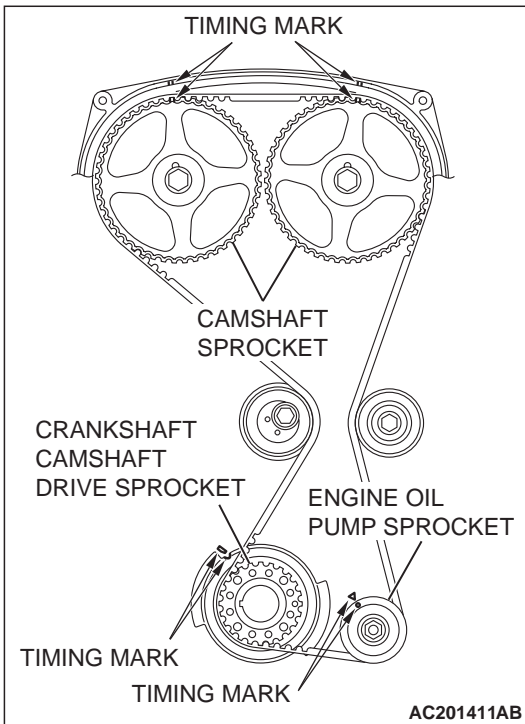

12. Check again that the timing marks on sprockets are aligned.

INSPECTION

M1112004400299

TIMING BELT TENSIONER ADJUSTER CHECK

1. Check for oil leak from seal, and replace it if leak is detected.
2. Check for wear or damage at the top of the rod. Replace it, if required.
3. Hold the timing belt tensioner adjuster by hand, and press the top end of the rod onto the metal (e.g. cylinder block) under a pressure of 98 – 196 N (22 – 44 pounds) to measure the movement of the rod.

Standard value: Within 1 mm (0.039 inch)

A: Length when it is free (not pressed)

B: Length when it is pressed

A – B: Movement

4. If the measured value is out of the standard value, replace the timing belt tensioner adjuster.

