

GROUP 17

ENGINE AND EMISSION CONTROL

CONTENTS

ENGINE CONTROL	17-3	AUTO-CRUISE CONTROL*	17-6
GENERAL DESCRIPTION	17-3	GENERAL DESCRIPTION	17-6
ENGINE CONTROL SYSTEM DIAGNOSIS	17-3	SPECIAL TOOLS	17-7
INTRODUCTION TO ENGINE CONTROL SYSTEM DIAGNOSIS	17-3	AUTO-CRUISE CONTROL SYSTEM DIAGNOSIS	17-7
ENGINE CONTROL SYSTEM DIAGNOSTIC TROUBLESHOOTING STRATEGY	17-3	INTRODUCTION TO AUTO-CRUISE CONTROL SYSTEM DIAGNOSIS	17-7
SYMPTOM CHART	17-3	AUTO-CRUISE CONTROL SYSTEM DIAGNOSTIC TROUBLESHOOTING STRATEGY	17-7
SYMPTOM PROCEDURES	17-3	AUTO-CRUISE CONTROL SYSTEM DIAGNOSTIC TROUBLE CODE DIAGNOSIS	17-8
ON-VEHICLE SERVICE	17-4	DIAGNOSTIC TROUBLE CODE CHART	17-11
ACCELERATOR CABLE CHECK AND ADJUSTMENT	17-4	DIAGNOSTIC TROUBLE CODE PROCEDURES	17-11
ACCELERATOR CABLE	17-5		
REMOVAL AND INSTALLATION	17-5		

Continued on next page

WARNINGS REGARDING SERVICING OF SUPPLEMENTAL RESTRAINT SYSTEM (SRS) EQUIPPED VEHICLES

⚠ WARNING

- *Improper service or maintenance of any component of the SRS, or any SRS-related component, can lead to personal injury or death to service personnel (from inadvertent firing of the air bag) or to the driver and passenger (from rendering the SRS inoperative).*
- *Service or maintenance of any SRS component or SRS-related component must be performed only at an authorized MITSUBISHI dealer.*
- *MITSUBISHI dealer personnel must thoroughly review this manual, and especially its GROUP 52B - Supplemental Restraint System (SRS) before beginning any service or maintenance of any component of the SRS or any SRS-related component.*

NOTE

The SRS includes the following components: SRS air bag control unit, SRS warning light, front impact sensors, air bag module, clock spring, and interconnecting wiring. Other SRS-related components (that may have to be removed/installed in connection with SRS service or maintenance) are indicated in the table of contents by an asterisk (*).

SYMPTOM CHART	17-57	SOLENOID CHECK	17-114
SYMPTOM PROCEDURES	17-58	VOLUME AIR FLOW SENSOR CHECK	17-115
DATA LIST REFERENCE TABLE	17-98	BAROMETRIC PRESSURE SENSOR	
CHECK AUTO-CRUISE CONTROL-ECU		CHECK	17-115
TERMINALS	17-99	ENGINE COOLANT TEMPERATURE	
ON-VEHICLE SERVICE	17-101	SENSOR CHECK	17-115
AUTO-CRUISE CONTROL SWITCH		INTAKE AIR TEMPERATURE SENSOR	
CHECK	17-101	CHECK	17-115
AUTO-CRUISE CONTROL SYSTEM		FUEL TANK DIFFERENTIAL PRESSURE	
COMPONENT CHECK	17-102	SENSOR CHECK	17-115
AUTO-CRUISE CONTROL	17-105	EVAPORATIVE EMISSION VENTILATION	
REMOVAL AND INSTALLATION	17-105	SOLENOID CHECK	17-115
EMISSION CONTROL	17-107	EXHAUST GAS RECIRCULATION (EGR)	
GENERAL DESCRIPTION	17-107	SYSTEM	17-115
DIAGNOSIS	17-107	GENERAL INFORMATION	17-115
SPECIAL TOOLS	17-108	COMPONENT LOCATION	17-116
VACUUM HOSES	17-108	EGR SYSTEM CHECK	17-117
VACUUM HOSE ROUTING	17-108	VACUUM CONTROL VALVE CHECK ..	17-117
VACUUM CIRCUIT DIAGRAM	17-109	EGR VALVE CHECK	17-118
VACUUM HOSE INSTALLATION	17-109	EGR PORT VACUUM CHECK	17-118
VACUUM HOSE CHECK	17-110	EGR SOLENOID CHECK	17-119
POSITIVE CRANKCASE VENTILATION		VOLUME AIR FLOW SENSOR CHECK	17-119
SYSTEM	17-110	ENGINE COOLANT TEMPERATURE	
GENERAL INFORMATION (POSITIVE		SENSOR CHECK	17-119
CRANKCASE VENTILATION SYSTEM)	17-110	CRANKSHAFT POSITION SENSOR	
COMPONENT LOCATION	17-111	CHECK	17-119
CRANKCASE VENTILATION SYSTEM		EVAPORATIVE EMISSION CANISTER	
CHECK	17-111	AND FUEL TANK PRESSURE RELIEF	
POSITIVE CRANKCASE VENTILATION (PCV)		VALVE	17-120
VALVE CHECK	17-111	REMOVAL AND INSTALLATION	17-120
EVAPORATIVE EMISSION CONTROL		INSPECTION	17-120
SYSTEM	17-111	CATALYTIC CONVERTER	17-122
GENERAL INFORMATION	17-111	GENERAL INFORMATION (CATALYTIC	
COMPONENT LOCATION	17-113	CONVERTER)	17-122
PURGE CONTROL SYSTEM CHECK		REMOVAL AND INSTALLATION	17-122
(PURGE FLOW CHECK)	17-113	SPECIFICATIONS	17-123
EVAPORATIVE EMISSION PURGE		FASTENER TIGHTENING	
		SPECIFICATIONS	17-123
		SERVICE SPECIFICATIONS	17-123

ENGINE CONTROL

GENERAL DESCRIPTION

M1171000100103

A cable-type accelerator mechanical suspended-type pedal has been adopted.

ENGINE CONTROL SYSTEM DIAGNOSIS

INTRODUCTION TO ENGINE CONTROL SYSTEM DIAGNOSIS

M1171002000102

If there is a malfunction in the engine control system, the accelerator cable, accelerator pedal or throttle lever may be faulty.

ENGINE CONTROL SYSTEM DIAGNOSTIC TROUBLESHOOTING STRATEGY

M1171002100121

Use these steps to plan your diagnostic strategy. If you follow them carefully, you will be sure that you have exhausted most of the possible ways to find an engine control system fault.

1. Gather information from the customer.

2. Verify that the condition described by the customer exists.
3. Find the malfunction by following the Symptom Chart.
4. Verify that the malfunction is eliminated.

SYMPTOM CHART

M1171002200128

SYMPTOMS	INSPECTION PROCEDURE	REFERENCE PAGE
Throttle valve will not fully open or close	1	P.17-3
Accelerator pedal operation not smooth (over acceleration)	2	P.17-4

SYMPTOM PROCEDURES

INSPECTION PROCEDURE 1: Throttle Valve Will Not Fully Open or Close

DIAGNOSIS

STEP 1. Check the accelerator cable adjustment.

Q: Is the accelerator cable properly adjusted?

YES : Go to Step 2.

NO : Adjust the accelerator cable by referring to P.17-4, and then go to Step 4.

STEP 2. Check the return spring.

Q: Is the return spring damaged or deformed?

YES : Go to Step 3.

NO : Replace, then go to Step 4.

STEP 3. Check the throttle lever.

Q: Is the throttle lever damaged or deformed?

YES : Replace, then go to Step 4.

NO : There is no action to be taken.

STEP 4. Check symptom.

Q: Does the throttle valve fully open and close?

YES : This diagnosis is complete.

NO : Return to Step 1.

INSPECTION PROCEDURE 2: Accelerator Pedal Operation Not Smooth (Over Acceleration)**DIAGNOSIS****STEP 1. Check the accelerator pedal.**

- Q: Is the accelerator pedal loose?**
YES : Tighten, then go to Step 4.
NO : Go to Step 2.

STEP 2. Check the accelerator cable wiring.

- Q: Is the accelerator cable routing bent sharply?**
YES : Repair, then go to Step 4.
NO : Go to Step 3.

STEP 3. Check the accelerator cable lubricant.

- Q: Is the accelerator cable lubricated sufficiently?**
YES : There is no action to be taken.
NO : Refill or replace the lubricant, then go to Step 4.

STEP 4. Check symptom.

- Q: Does the accelerator pedal work normally?**
YES : This diagnosis is complete.
NO : Go to Step 1.

ON-VEHICLE SERVICE**ACCELERATOR CABLE CHECK AND ADJUSTMENT**

M1171000900132

1. Turn off air conditioning and all lights. Inspect and adjust at no load.
2. Start engine and allow to idle until it reaches normal operating temperature.
3. Confirm the idle speed is at standard value.
Standard value: 700 ± 50 r/min
4. Stop the engine (ignition switch the "LOCK" (OFF) position).
5. Confirm there are no sharp bends in the accelerator cable.
6. Check the inner cable for correct slack.
Standard value: 1 – 2 mm (0.04 – 0.08 inch)
7. If there is too much slack or no slack, adjust the cable as follows:
 - (1) Loosen the adjusting bolt to release the cable.
 - (2) Move the plate until the inner cable play is at the standard value, and then tighten the adjusting bolt to specified torque.

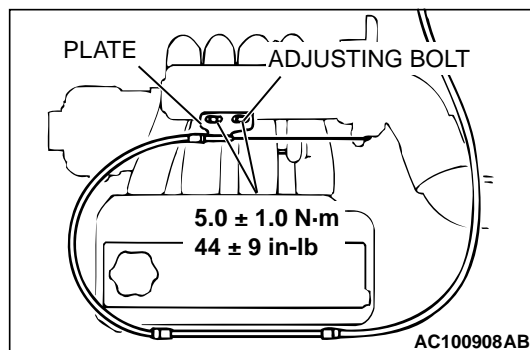

**ACCELERATOR CABLE AND PEDAL
REMOVAL AND INSTALLATION**

M1171001200266

Post-installation Operation

Adjusting the Accelerator Cable (Refer to P.17-4.)

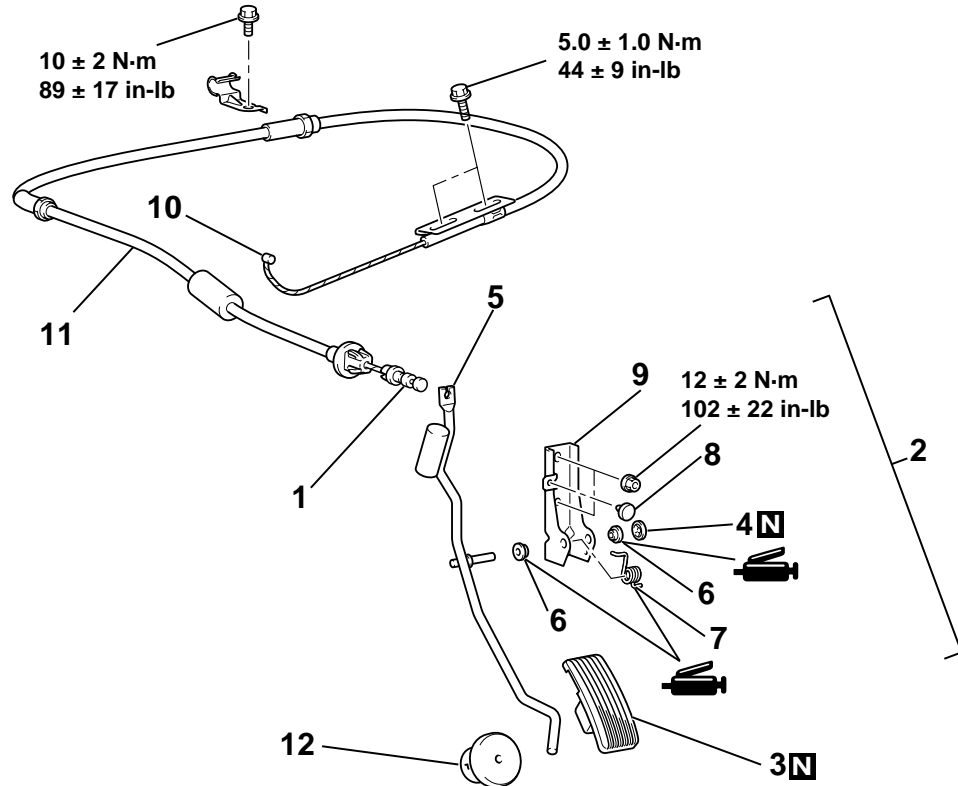

AC100452AB

REMOVAL STEPS

- >>A<<
1. INNER CABLE CONNECTION (ACCELERATOR PEDAL SIDE)
 2. ACCELERATOR PEDAL ASSEMBLY
 3. PEDAL PAD
 4. PUSH-ON SPRING NUT
 5. ACCELERATOR ARM ASSEMBLY
 6. BUSHING

REMOVAL STEPS (Continued)

7. SPRING
8. STOPPER
9. ACCELERATOR PEDAL BRACKET
10. INNER CABLE CONNECTION (THROTTLE LEVER SIDE)
11. ACCELERATOR CABLE ASSEMBLY
12. ACCELERATOR PEDAL STOPPER

INSTALLATION SERVICE POINT

>>A<< ACCELERATOR PEDAL PAD INSTALLATION

Warm the peg of the accelerator pedal pad with a dryer before installing the pad.

NOTE: If it is difficult to fit, apply soapy water to the peg lightly.

AUTO-CRUISE CONTROL

GENERAL DESCRIPTION

M1172000100214

By using the auto-cruise control, the driver can drive at the desired speed [in a range of approximately 40 – 200 km/h (25 – 124 mph)] without depressing the accelerator pedal.

CONSTRUCTION DIAGRAM

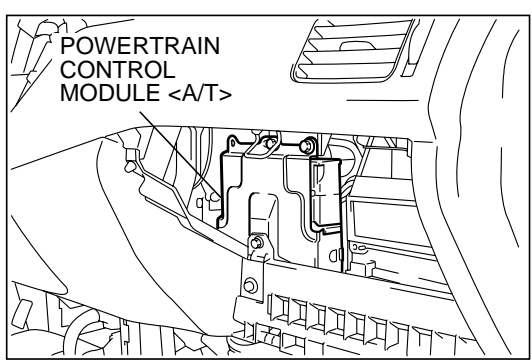
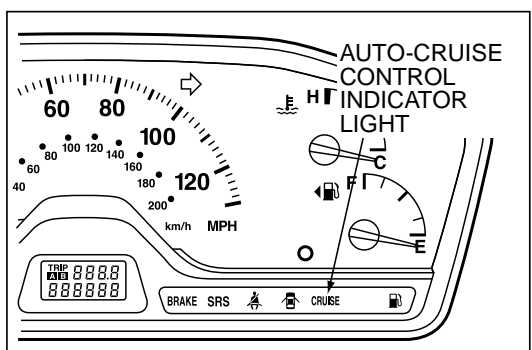
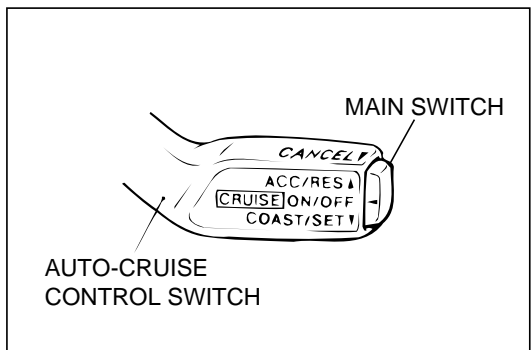
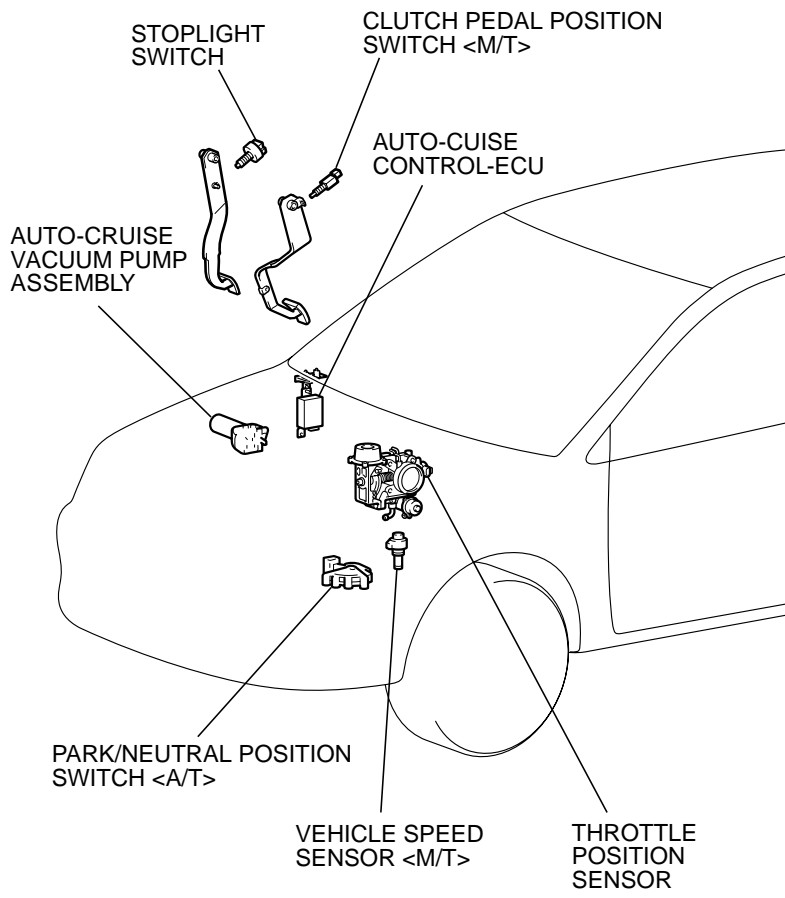

AC100455 AB

cardiagn.com

SPECIAL TOOLS

M1172000600219

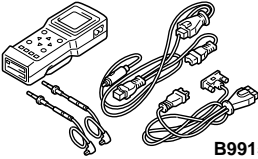
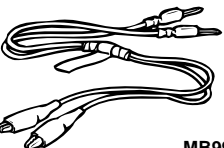
TOOL	TOOL NUMBER AND NAME	SUPERSESSION	APPLICATION
 B991502	MB991502 Scan tool (MUT-II)	MB991496-OD	Diagnostic trouble code check.
 MB991529	MB991529 Diagnostic trouble code check harness	Tool not necessary if scan tool (MUT-II) is available	

AUTO-CRUISE CONTROL SYSTEM DIAGNOSIS

INTRODUCTION TO AUTO-CRUISE CONTROL SYSTEM DIAGNOSIS

M1172003300206

The auto-cruise control system allows driving without stepping on the accelerator pedal by setting a random speed between 40 km/h (25 mph) and 200 km/h (124 mph). Problems in this system can be investigated by the following methods.

Auto-cruise control system diagnostic trouble codes

The auto-cruise control system consists of the auto-cruise control-ECU, control switches, sensors, and vacuum pump. The control switches and sensors monitor the state of the vehicle. Based on input signals from those switches and sensors, the auto-

cruise control-ECU activates the vacuum pump. If the auto-cruise control-ECU detects a problem on any of those components, the ECU estimates where the problem may be occurring, and will output a diagnostic trouble code. Diagnostic trouble codes cover the throttle position sensor, auto-cruise control switch, vehicle speed sensor, auto-cruise control-ECU and vacuum pump.

AUTO-CRUISE CONTROL SYSTEM DIAGNOSTIC TROUBLESHOOTING STRATEGY

M1172002000097

Use these steps to plan your diagnostic strategy. If you follow them carefully, you will check most of the possible causes of an auto-cruise control system problem.

1. Gather information from the customer.
2. Verify that the condition described by the customer exists.
3. Check the vehicle for any auto-cruise control system DTC.
4. If you can verify the condition and there are no auto-cruise control system DTCs, and the malfunction is intermittent, refer to GROUP 00, HOW TO USE TROUBLESHOOTING/ INSPECTION SERVICE POINTS – How to Cope with Intermittent Malfunctions P.00-6.

- If the same Auto-cruise Control System DTC sets again, perform the diagnostic procedures for the

5. If you can verify the condition but there are no auto-cruise control system DTCs, or the system cannot communicate with the scan tool, check that the auto-cruise control system is operating properly.
 - If the auto-cruise control system is operating properly, refer to, Auto-cruise Control System Data List Reference Table.
 - If the auto-cruise control system is operating properly, refer to, Auto-cruise Control System Diagnostic Trouble Code Chart.
6. If there is an auto-cruise control system DTC, record the number of the code, then erase the code from vehicle memory using the scan tool.
7. Re-create the auto-cruise control system DTC set conditions to see if the same Auto-cruise Control System DTC will set again.
 - set code. Refer to, Auto-cruise Control System Diagnostic Trouble Code Chart.

**AUTO-CRUISE CONTROL SYSTEM DIAGNOSTIC
TROUBLE CODE DIAGNOSIS**

M1172002100209

Retrieving Auto-cruise Control System Diagnostic Trouble Codes.

Using scan tool MB991502**Required Special Tool:**

- MB991502: Scan Tool (MUT-II)

⚠ CAUTION

To prevent damage to scan tool MB991502, always turn the ignition switch to the "LOCK" (OFF) position before connecting or disconnecting scan tool MB991502.

1. Connect scan tool MB991502 to the data link connector.
2. Turn the ignition switch to the "ON" position.
3. Use scan tool MB991502 to check for auto-cruise control system diagnostic trouble codes.
4. Turn the ignition switch to the "LOCK" (OFF) position.
5. Disconnect scan tool MB991502.

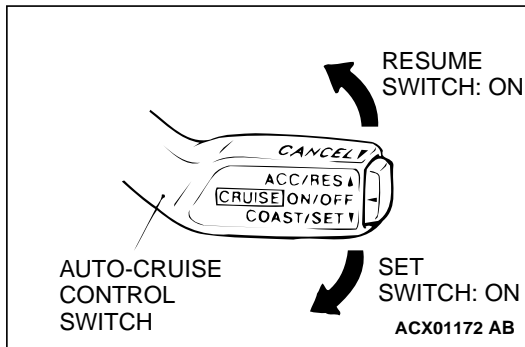
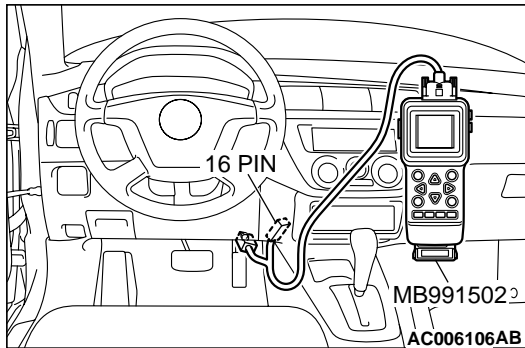
**Using a Auto-cruise Control Indicator Light**

1. Turn the ignition switch to the "ON" position while holding the auto-cruise control switch in the "SET" position (down). Then, within one second, move the cruise control switch up to the "RES" position.
2. Read a diagnostic trouble code by observing the flash display pattern of the auto-cruise control indicator light in the combination meter.

DIAGNOSTIC RESULT DISPLAY METHOD WHEN USING THE AUTO-CRUISE CONTROL INDICATOR LIGHT

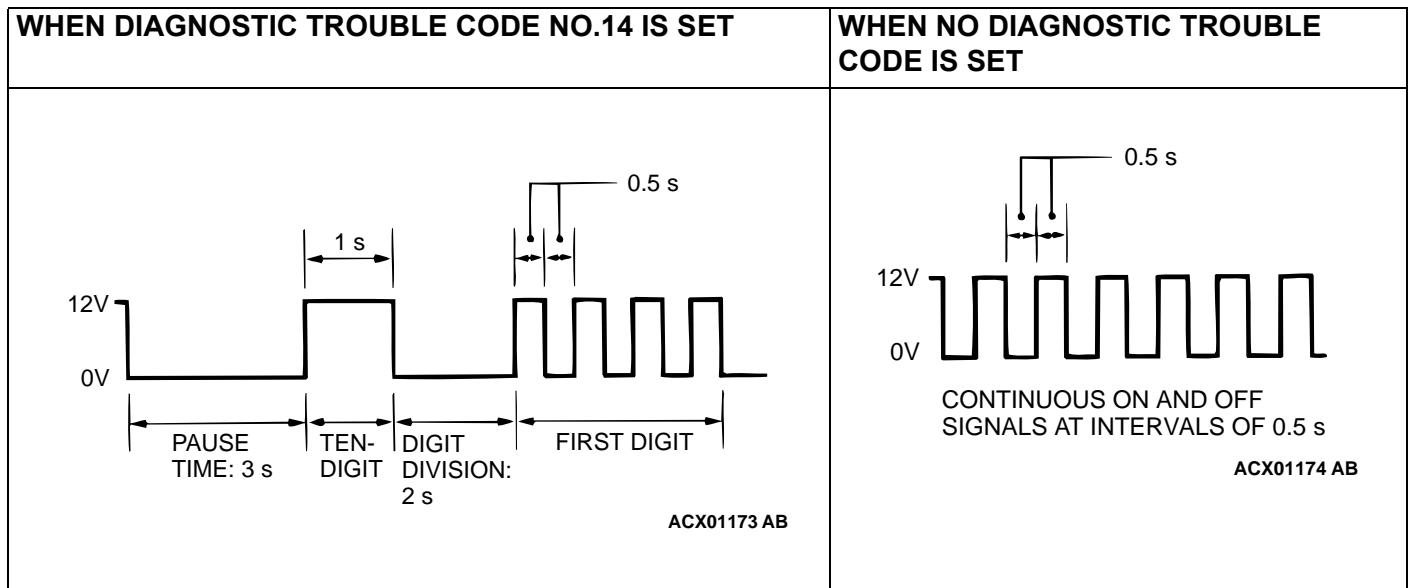

NOTE: Other on-board diagnostic items are also output as voltage waveforms corresponding to diagnostic trouble code numbers.

Erasing Diagnostic Trouble Codes

The diagnostic trouble codes can be erased by the following procedure.

NOTE: The diagnostic trouble code will not be erased even if the negative battery terminal is disconnected.

Using scan tool MB991502

Required Special Tool:

- MB991502: Scan Tool (MUT-II)

CAUTION

To prevent damage to scan tool MB991502, always turn the ignition switch to the "LOCK" (OFF) position before connecting or disconnecting scan tool MB991502.

1. Connect scan tool MB991502 to the data link connector.
2. Turn the ignition switch to the "ON" position.
3. Use scan tool MB991502 to check for auto-cruise control system diagnostic trouble codes.
4. Turn the ignition switch to the "LOCK" (OFF) position.
5. Disconnect scan tool MB991502.

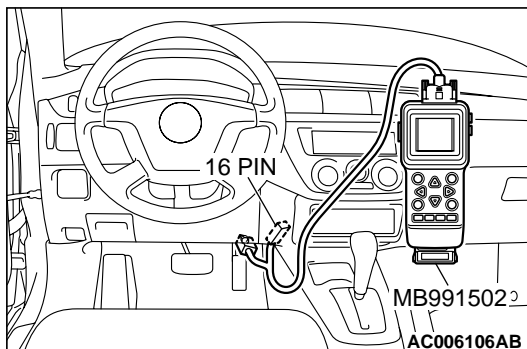

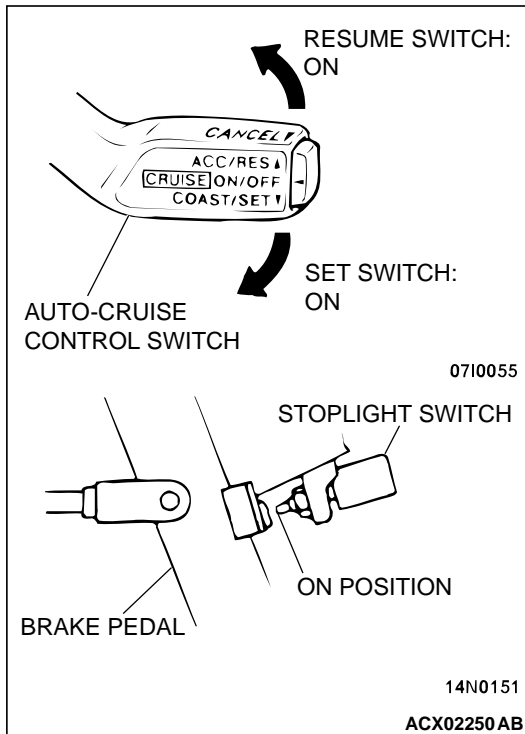
**Without using scan tool MB991502**

1. Turn the ignition switch to the "ON" position while holding the auto-cruise control switch in the "SET" (down) position. Then, within one second, move the cruise control switch up to the "RES" position.
2. Check to make sure the "CRUISE" light on the instrument panel is flashing.
3. Put the auto-cruise control switch in the "SET" (down) position. Depress the brake pedal and hold for five seconds or more. Release the brake pedal, auto-cruise control switch, then turn the ignition switch to the "LOCK" (OFF) position. The DTC(s) are now erased.

**INSPECTION USING SCAN TOOL MB991502,
DATA LIST****Required Special Tool:**

- MB991502: Scan Tool (MUT-II)

CAUTION

To prevent damage to scan tool MB991502, always turn the ignition switch to the "LOCK" (OFF) position before connecting or disconnecting scan tool MB991502.

1. Connect scan tool MB991502 to the data link connector.
2. Turn the ignition switch to the "ON" position.
3. Carry out inspection by means of the data list. If there is an abnormality, check and repair the chassis harnesses and components. (Refer to P.17-98, Data List Reference Table.)
4. Re-check using scan tool MB991502 and check to be sure that the abnormal input and output have returned to normal because of the repairs.
5. Erase the diagnostic trouble code(s).
6. Turn the ignition switch to the "LOCK" (OFF) position.
7. Disconnect scan tool MB991502 from the data link connector.
8. Start the engine again and do a test drive to confirm that the problem is eliminated.

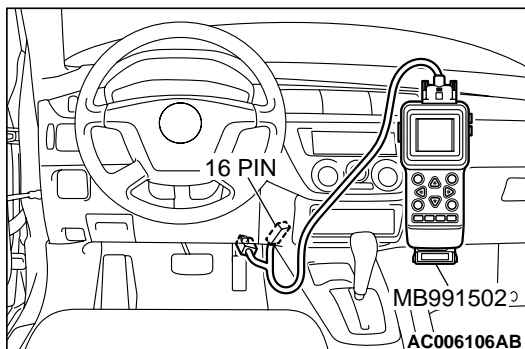

DIAGNOSTIC TROUBLE CODE CHART

M1172002200239

Check according to the inspection chart that is appropriate for the diagnostic trouble code.

DTC	INSPECTION ITEM	REFERENCE PAGE
11	Auto-cruise vacuum pump drive system	P.17-11
12	Vehicle speed signal system <M/T>	P.17-17
	Vehicle speed signal system <A/T>	P.17-20
14	Auto-cruise vacuum pump power supply system	P.17-22
15	Auto-cruise control switch system	P.17-36
16	Auto-cruise control-ECU system	P.17-44
17	Throttle position sensor and, idle position signal system <M/T>	P.17-44
	Throttle position sensor and, idle position signal system <A/T>	P.17-51

DIAGNOSTIC TROUBLE CODE PROCEDURES

DTC 11: Auto-cruise Vacuum Pump Drive System

Auto-cruise Vacuum Pump Drive System Circuit

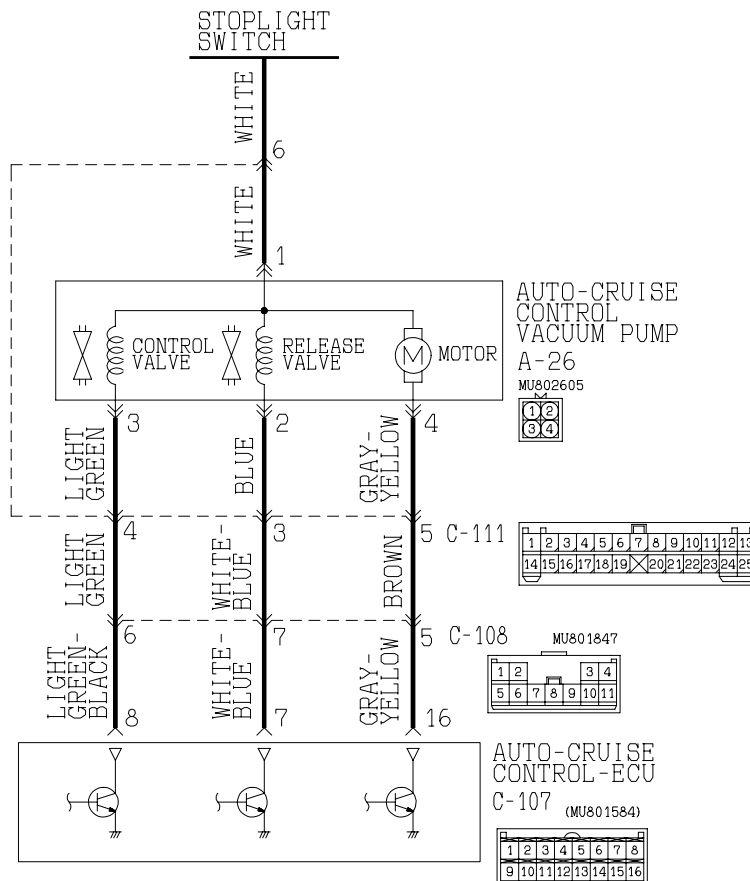

W2J09M05AA

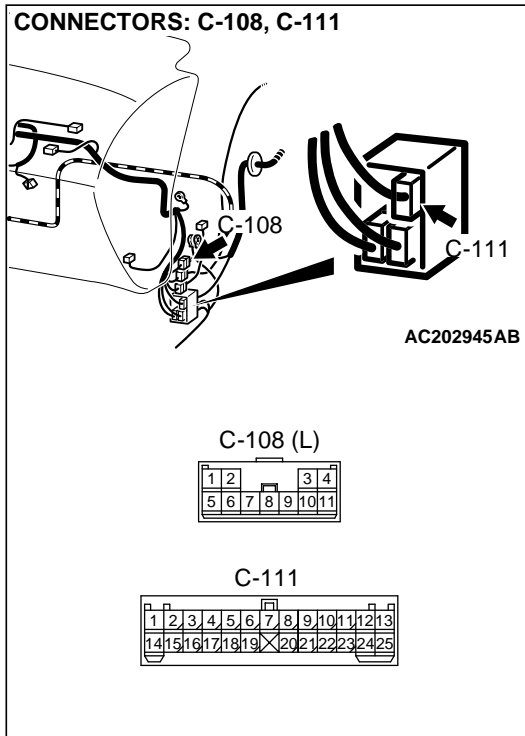
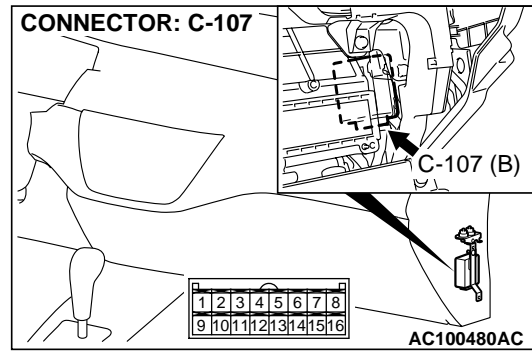
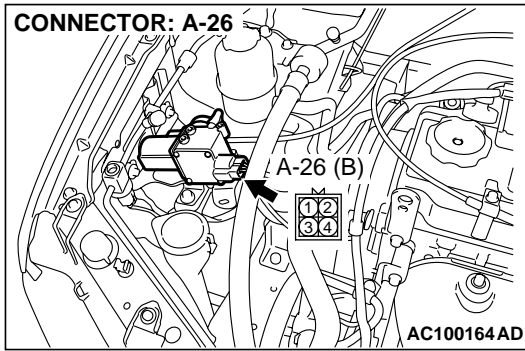

CIRCUIT OPERATION

This circuit activates the vacuum pump used to accelerate/decelerate, set, and cancel the vehicle speed.

The auto-cruise control-ECU controls the control valve, release valve, and motor by turning the transistor in the ECU on and off.

DTC SET CONDITIONS

Any drive signal for the release valve, control valve or motor is not input to the auto-cruise control-ECU.

TROUBLESHOOTING HINTS

The most likely causes for this code to be set are:

- Malfunction of the auto-cruise vacuum pump.
- Damaged harness or connector.
- Malfunction of the auto-cruise control-ECU.

DIAGNOSIS

Required Special Tool:

- MB991223: Harness Set

STEP 1. Measure the signal voltage at auto-cruise control-ECU connector C-107 by backprobing.

- (1) Remove the auto-cruise control-ECU mounting nut. Refer to [P.17-105](#).
- (2) Do not disconnect auto-cruise control-ECU connector C-107.
- (3) Turn the ignition switch to the "ON" position and the auto-cruise control main switch to the "ON" position.

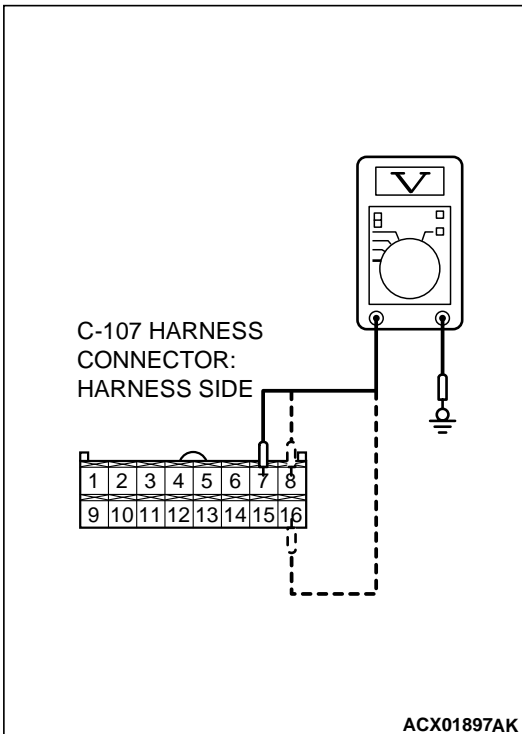
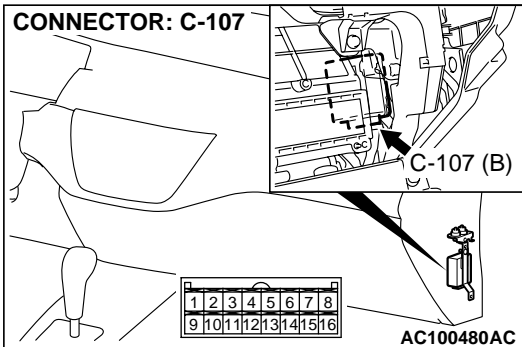

- (4) Measure the voltage between auto-cruise control-ECU connector C-107 terminal 7 and ground by backprobing.
 - voltage should measure battery positive voltage. [When decelerating with the "SET" switch while driving at constant speed (Release valve open).]
- (5) Measure the voltage between terminal 8 and ground by backprobing.
 - voltage should measure battery positive voltage. [When decelerating with the "SET" switch while driving at constant speed. (Control valve open).]
- (6) Measure the voltage between terminal 16 and ground by backprobing.
 - voltage should measure battery positive voltage. (When the motor is stopped during a constant road speed.)
- (7) Turn the ignition switch to the "LOCK" (OFF) position.

Q: Are all of the measured voltages satisfied?

YES : Check that diagnostic trouble code 11 is not output. If diagnostic trouble code 11 is output, replace the auto-cruise control-ECU. (Refer to [P.00E-2](#).) Then check that diagnostic trouble code 11 is not output.

NO : Go to Step 2.

STEP 2. Check auto-cruise control-ECU connector C-107 and intermediate connector C-108, C-111 for loose, corroded or damaged terminals, or terminals pushed back in the connector.

Q: Are the connectors and terminals in good condition?

YES : Go to Step 3.

NO : Repair or replace connector. Refer to GROUP 00E, Harness Connector Inspection [P.00E-2](#). Then check that diagnostic trouble code 11 is not output.

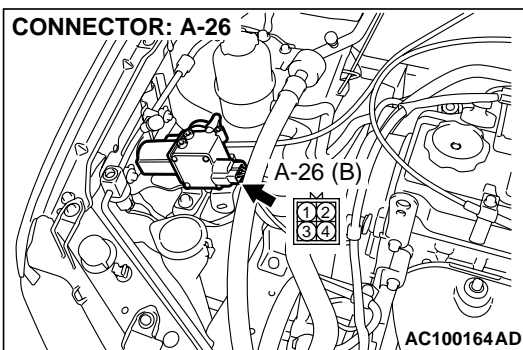
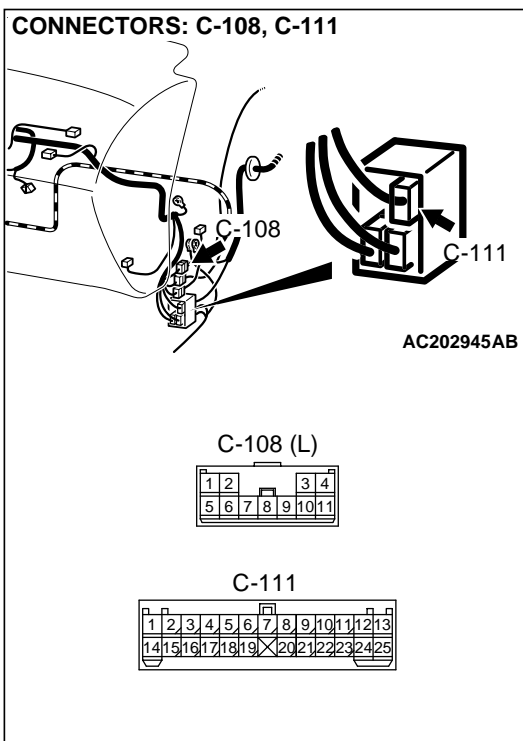
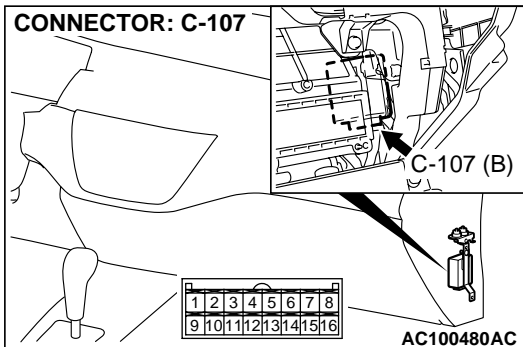

STEP 3. Check auto-cruise control vacuum pump connector A-26 for loose, corroded or damaged terminals, or terminals pushed back in the connector.

Q: Are the connector and terminals in good condition?

YES : Go to Step 4.

NO : Repair or replace connector. Refer to GROUP 00E Harness Connector Inspection [P.17-105](#). Then check that diagnostic trouble code 11 is not output.

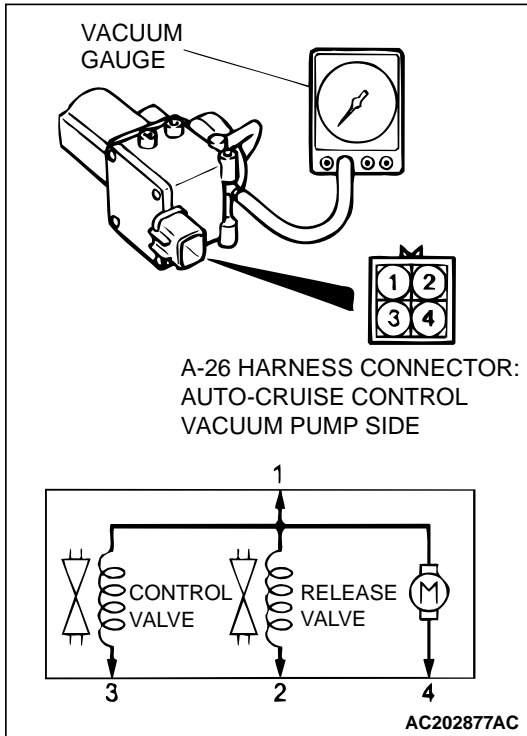

STEP 4. Check the auto-cruise control vacuum pump.

- (1) Disconnect the vacuum hose from the auto-cruise control vacuum pump and connect a vacuum gauge to the vacuum pump.
- (2) Disconnect the vacuum pump connector.
- (3) Check the auto-cruise control vacuum pump and valves according to the following procedure:
 - a. Connect the positive battery terminal to auto-cruise control vacuum pump connector terminal 1, and the negative battery terminal to terminals 2, 3, and 4. The vacuum gauge should read 27 kPa (8.0 in Hg) or more.
 - b. The vacuum should be maintained when terminal 4 is disconnected from the negative battery terminal while terminals 1, 2, and 3 remain connected. Then the vacuum gauge should read 0 kPa (0 in Hg) when terminal 2 is disconnected from the negative battery terminal while terminals 1, and 3 remain connected.
 - c. The vacuum should be maintained when terminal 4 is disconnected from the negative battery terminal while terminals 1, 2, and 3 remain connected. Then the vacuum gauge should read 0 kPa (0 in Hg) when terminal 3 is disconnected from the negative battery terminal while terminals 1, and 2 remain connected.

Q: Are all of the above values satisfied?

YES : Go to Step 5.

No : Replace the auto-cruise control vacuum pump. (Refer to P.17-105.) Then check that diagnostic trouble code 11 is not output.

STEP 5. Check the harness wires between auto-cruise control vacuum pump connector A-26 terminal 2, 3, 4 and auto-cruise control-ECU connector C-107 terminal 7, 8, 16 for damage.

Q: Are the harness wires in good condition?

YES : Check that diagnostic trouble code 11 is not output. If diagnostic trouble code 11 is output, replace the auto-cruise control-ECU. (Refer to [P.17-105](#)). Then check that diagnostic trouble code 11 is not output.

NO : Repair the harness wire and then check that diagnostic trouble code 11 is not output.

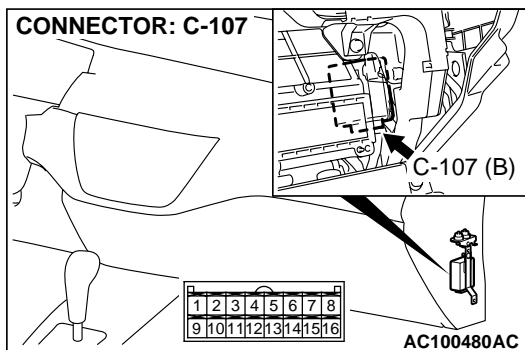
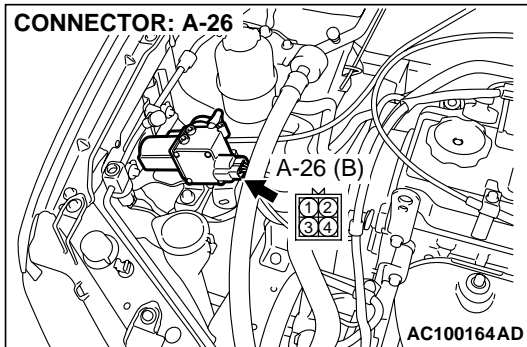

DTC 12: Vehicle Speed Signal System <M/T>

Vehicle Speed Signal System Circuit

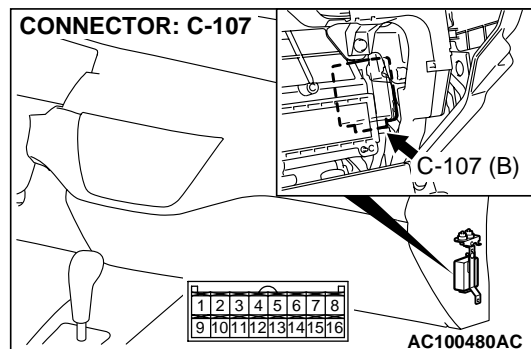
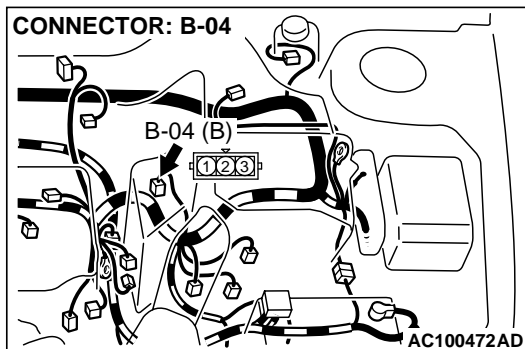
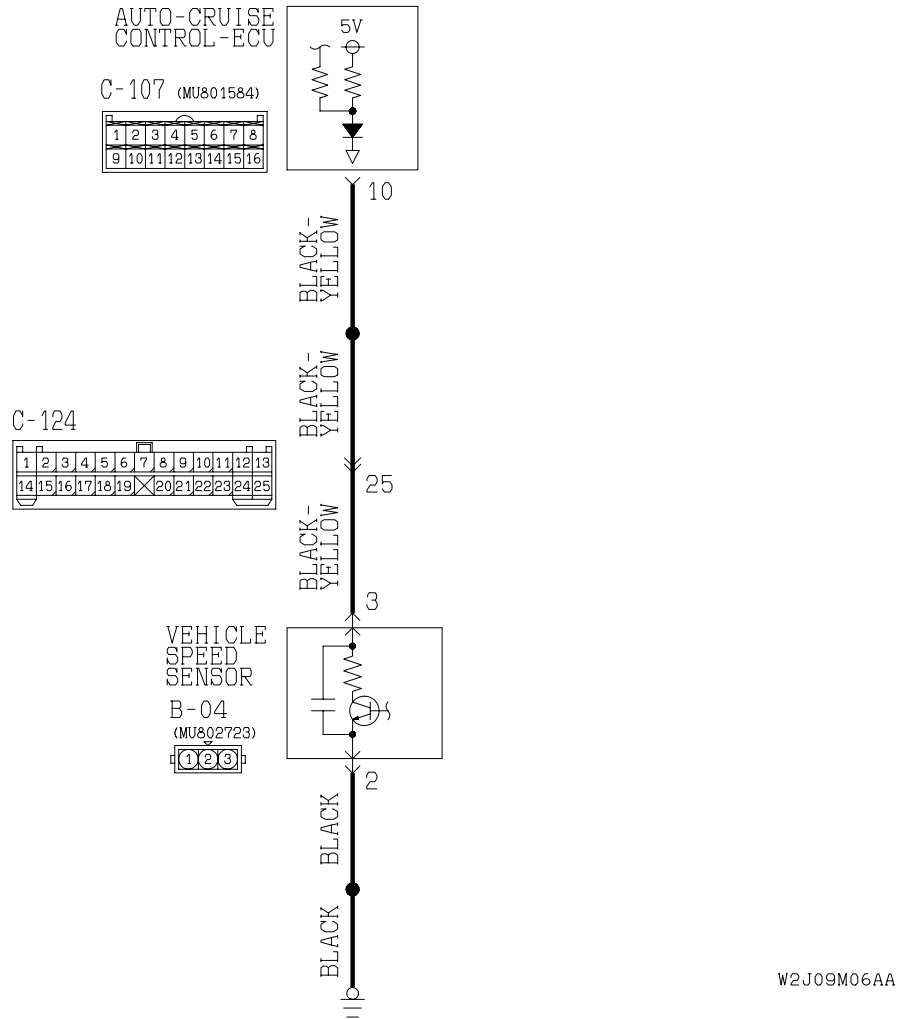

cardiagn.com

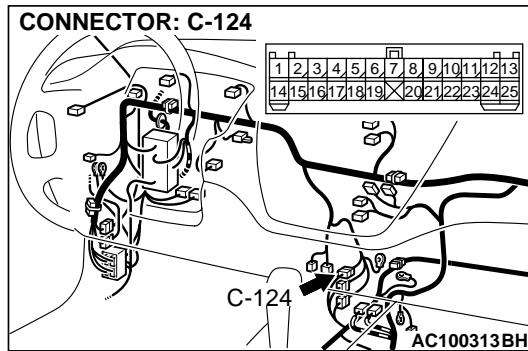
**CIRCUIT OPERATION**

This circuit checks the operation of the vehicle speed sensor.

When the vehicle moves forward and reverses, the sensor turns ON and OFF repeatedly.

DTC SET CONDITIONS

The vehicle speed signals from the vehicle speed sensor are not input to the auto-cruise control-ECU when the vehicle speed is 40 km/h (25 mph) or more.

TROUBLESHOOTING HINTS

The most likely causes for this code to be set are:

- Malfunction of the vehicle speed sensor.
- Damaged harness or connector.
- Malfunction of the auto-cruise control-ECU.

DIAGNOSIS**Required Special Tool:**

- MB991223: Harness Set

STEP 1. Check the speedometer.**Q: Does the speedometer work normally?**

YES : Go to Step 2.

NO : Check the speedometer circuit and repair or replace as required. (Refer to GROUP 54A, Combination Meter Assembly and Vehicle Speed Sensor [P.54A-15.](#))

STEP 2. Check intermediate connector C-124 for loose, corroded or damaged terminals, or terminals pushed back in the connector.**Q: Are the connector and terminals in good condition?**

YES : Go to Step 3

NO : Repair or replace connector. Refer to GROUP 00E, Harness Connector Inspection [P.00E-2.](#) Then check that diagnostic trouble code 12 is not output.

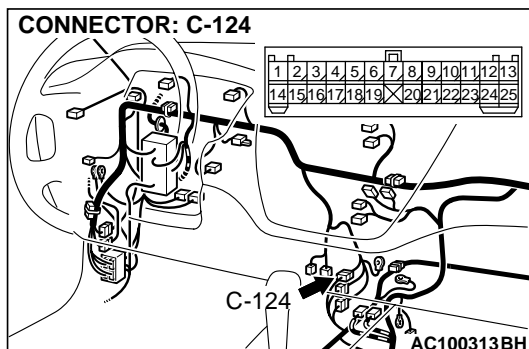

STEP 3. Check the harness wire between auto-cruise control-ECU connector C-107 terminal 10 and intermediate connector C-124 terminal 25 for damage.

Q: Is the harness wire in good condition?

- YES :** Check that diagnostic trouble code 12 is not output. If diagnostic trouble code 12 is output, replace the auto-cruise control-ECU. (Refer to [P.17-105.](#)) Then check that diagnostic trouble code 12 is not output.
- NO :** Repair the harness wire and then check that diagnostic trouble code 12 is not output.

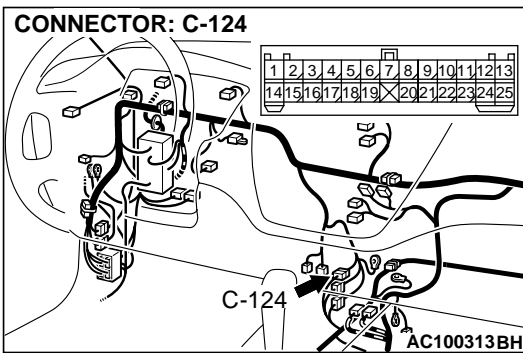
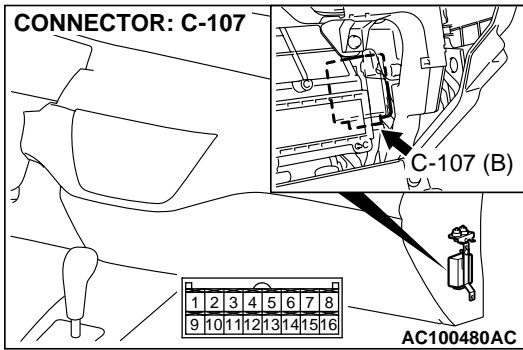

DTC 12: Vehicle Speed Signal System <A/T>

Vehicle Speed Signal System Circuit

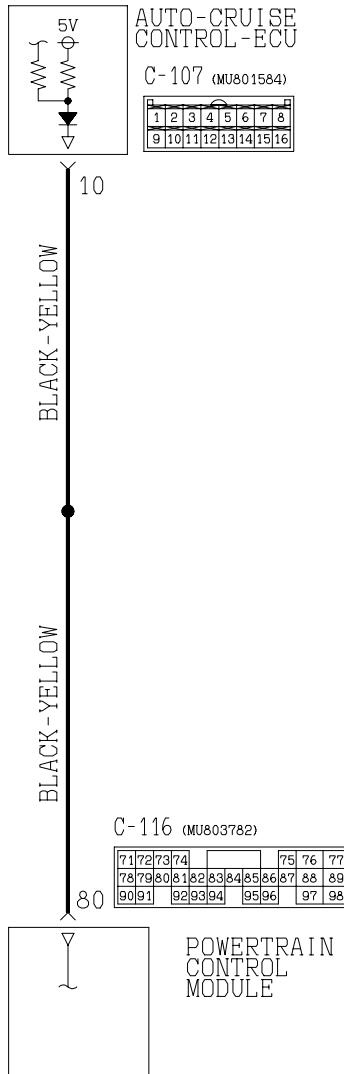

W2J09M08AA

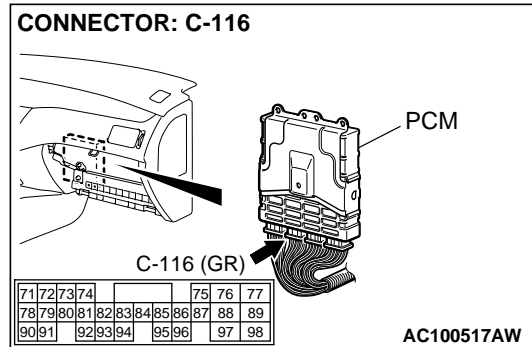
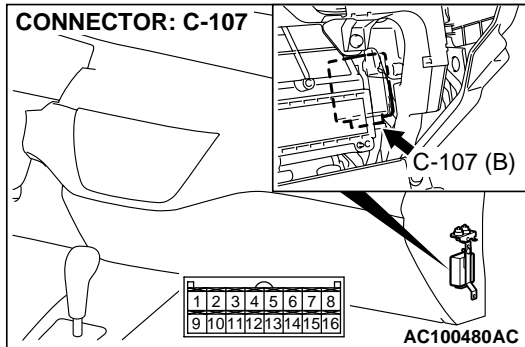

cardiagn.com

CIRCUIT OPERATION

This circuit checks the vehicle speed signal. When the vehicle moves forward and reverses, the sensor turns ON and OFF repeatedly.

DTC SET CONDITIONS

The vehicle speed signals from the PCM are not input to the auto-cruise control-ECU when the vehicle speed is 40 km/h (25 mph) or more.

TROUBLESHOOTING HINTS

The most likely causes for this code to be set are:

- Malfunction of the output shaft speed sensor.
- Malfunction of the PCM.
- Damaged harness or connector.
- Malfunction of the auto-cruise control-ECU.

DIAGNOSIS

Required Special Tool:

- MB991223: Harness Set

STEP 1. Check the speedometer.

Q: Does the speedometer work normally?

YES : Go to Step 2.

NO : Check the speedometer circuit and repair or replace as required. (Refer to GROUP 54A, Combination Meter Assembly and Vehicle Speed Sensor P.54A-10.)

STEP 2. Check the harness wire between auto-cruise control-ECU connector C-107 terminal 10 and PCM connector C-116 terminal 80 for damage.

Q: Is the harness wire in good condition?

YES : Check that diagnostic trouble code 12 is not output. If diagnostic trouble code 12 is output, replace the auto-cruise control-ECU. (Refer to P.17-105.) Then check that diagnostic trouble code 12 is not output.

NO : Repair the harness wire and then check that diagnostic trouble code 12 is not output.

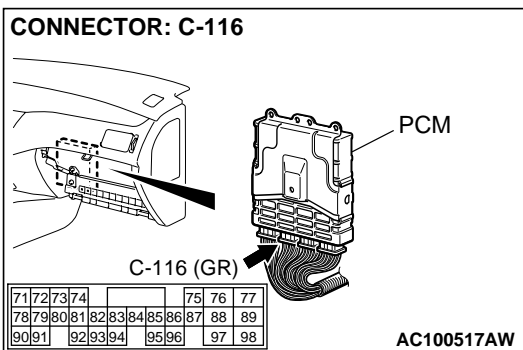
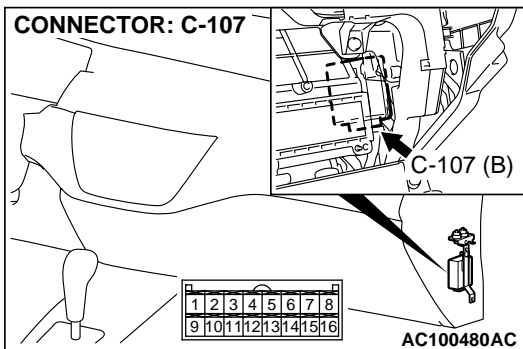

DTC 14 Auto-cruise Vacuum Pump Power Supply System

Auto-cruise Vacuum Pump Power Supply

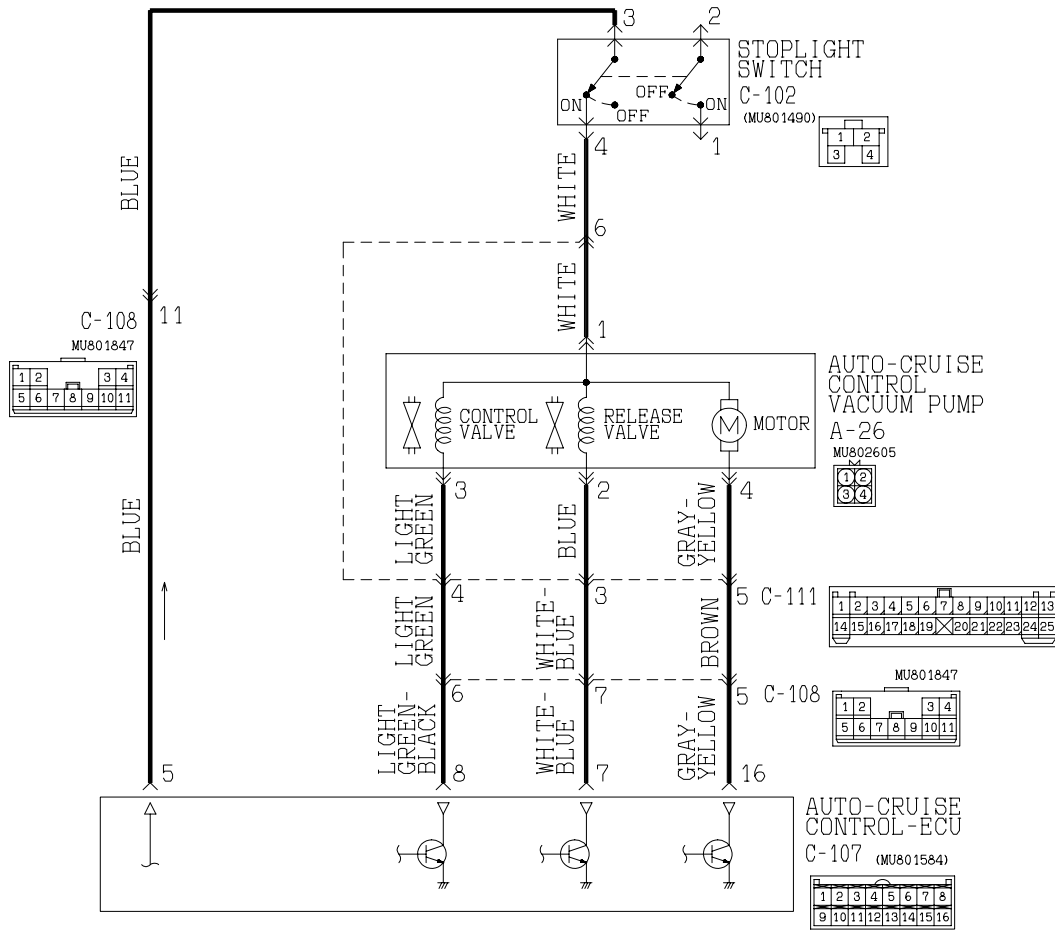

W2J09M04AA

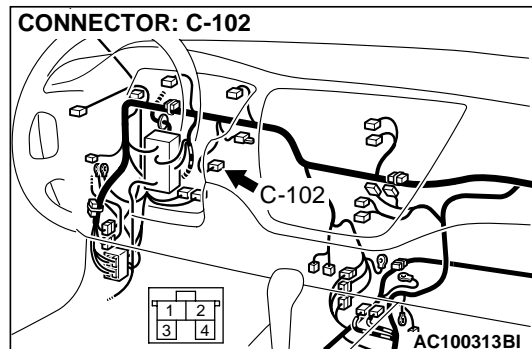
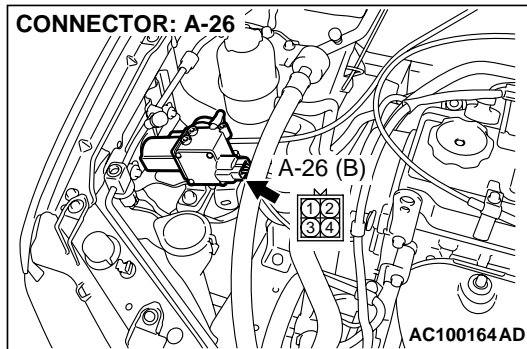

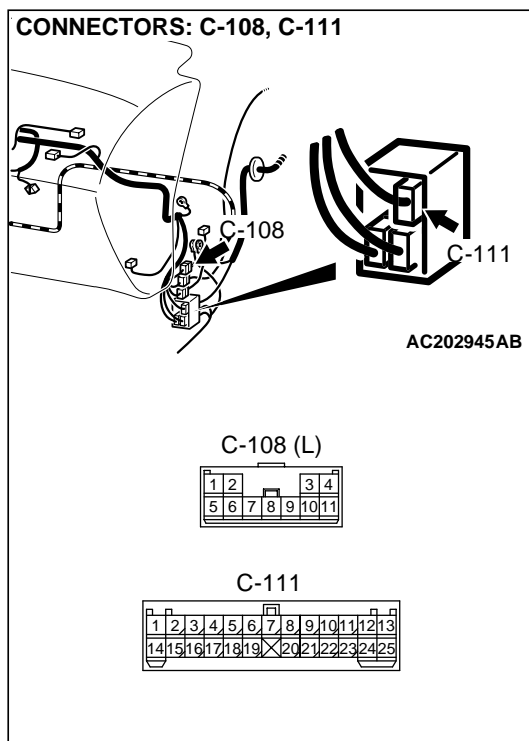
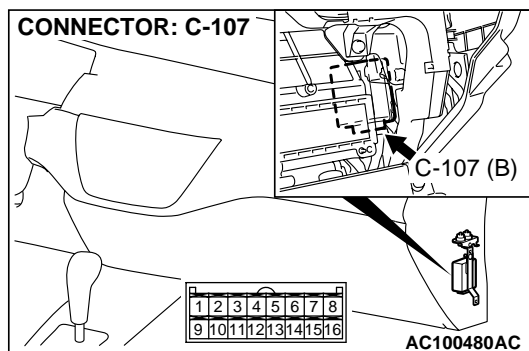

CIRCUIT OPERATION

This circuit supplies the power to the vacuum pump. The battery positive voltage is supplied to the auto-cruise control vacuum pump by turning on the transistor at terminal number 16 of the auto-cruise control-ECU. The conditions for turning on the transistor at terminal number 16 of the auto-cruise control-ECU are as follows.

- Ignition switch "ON"
- Auto-cruise control main switch "ON"
- Stoplight switch ON

DTC SET CONDITIONS

None of the drive signals from release valve, control valve and motor of the auto-cruise vacuum pump are input to the auto-cruise control-ECU.

TROUBLESHOOTING HINTS

The most likely causes for this code to be set are:

- Malfunction of the stoplight switch
- Malfunction of the auto-cruise vacuum pump
- Damaged harness or connector.
- Malfunction of the auto-cruise control-ECU

cardiagn.com

DIAGNOSIS**Required Special Tool:**

- MB991223: Harness Set

STEP 1. Measure the signal voltage at stoplight switch connector C-102 by backprobing.

- (1) Do not disconnect stoplight switch connector C-102.
- (2) Turn the ignition switch to the "ON" position.

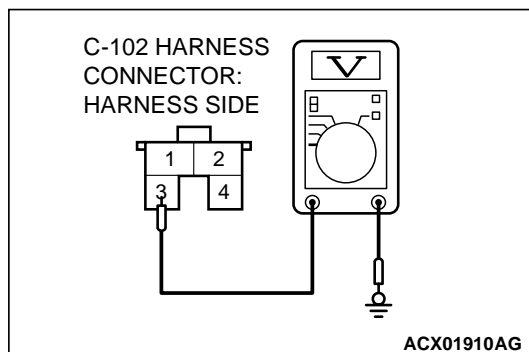
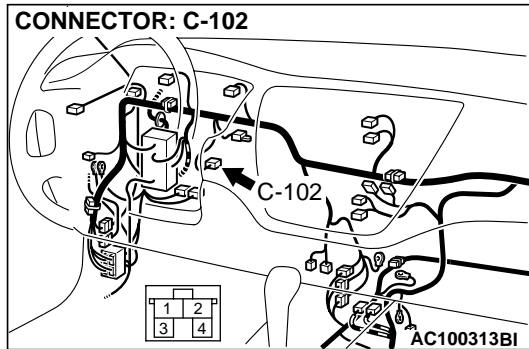

- (3) Measure the voltage between stoplight switch connector C-102 terminal 3 and ground by backprobing.
 - The measured voltage should measure battery positive voltage. (When brake pedal is depressed).
 - The measured voltage should measure 0 V. (When brake pedal is not depressed).
- (4) Turn the ignition switch to the "LOCK" (OFF) position.

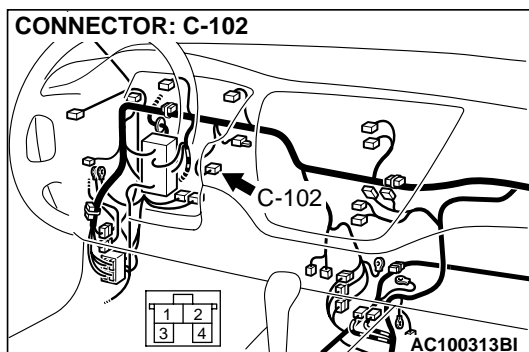
Q: Are all of the measured voltages satisfied?**YES** : Go to Step 3.**NO** : Go to Step 2.**STEP 2. Check stoplight switch connector C-102 for loose, corroded or damaged terminals, or terminals pushed back in the connector.****Q: Are the connector and terminals in good condition?****YES** : Go to Step 14.**NO** : Repair or replace connector. Refer to GROUP 00E, Harness Connector Inspection P.00E-2. Then check that diagnostic trouble code 14 is not output.

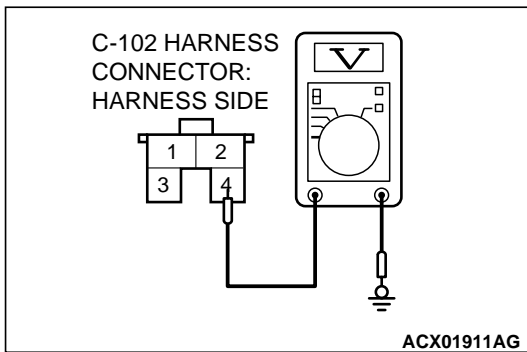
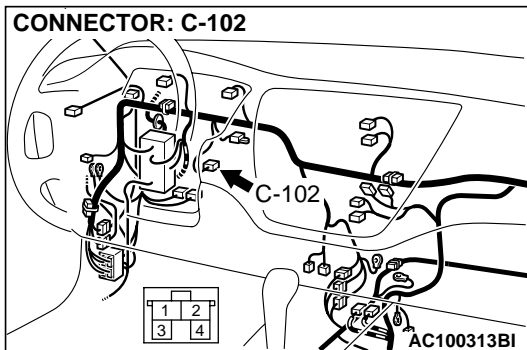

STEP 3. Measure the signal voltage at stoplight switch connector C-102 by backprobing.

- (1) Do not disconnect stoplight switch connector C-102.
- (2) Turn the ignition switch to the "ON" position and the auto-cruise control main switch to the "ON" position.

- (3) Measure the voltage between stoplight switch connector C-102 terminal 4 and ground by backprobing.

- The measured voltage should measure battery positive voltage. (When brake pedal is depressed).
- The measured voltage should measure 0 V. (When brake pedal is not depressed).

- (4) Turn the ignition switch to the "LOCK" (OFF) position.

Q: Are all of the measured voltages satisfied?

YES : Go to Step 6.

NO : Go to Step 4.

STEP 4. Check stoplight switch connector C-102 for loose, corroded or damaged terminals, or terminals pushed back in the connector.

Q: Are the connector and terminals in good condition?

YES : Go to Step 5.

NO : Repair or replace connector. Refer to GROUP 00E, Harness Connector Inspection [P.00E-2](#). Then check that diagnostic trouble code 14 is not output.

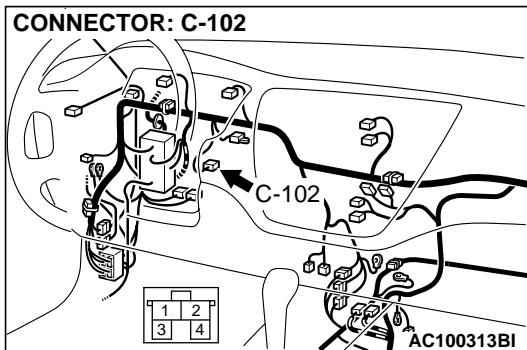

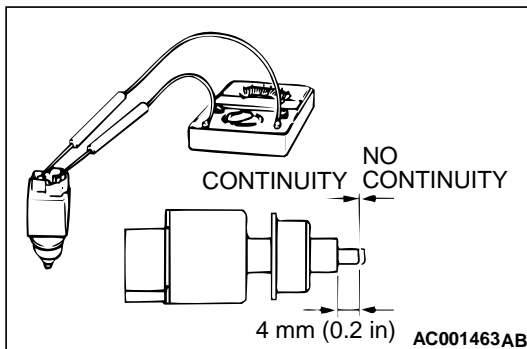
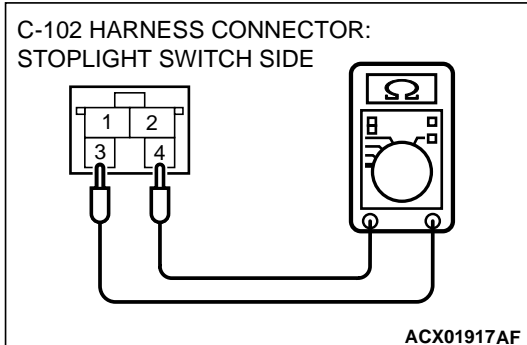
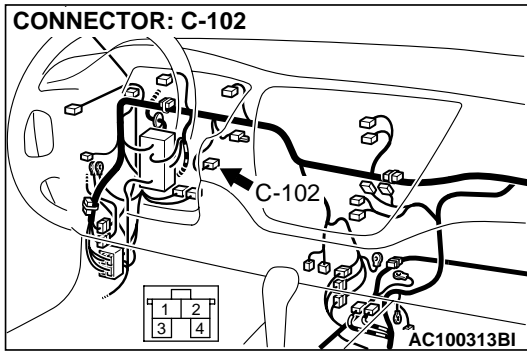
**STEP 5. Check the stoplight switch.**

(1) Disconnect stoplight switch connector C-102.

- (2) Connect an ohmmeter to the stoplight switch between terminals 3 and 4, and check whether there is continuity when the plunger of the stoplight switch is pushed in and an open circuit when it is released.
- (3) The stoplight switch is in good condition if the circuit is open when the plunger is pushed in to a depth of within 4 mm (0.2 inch) from the outer case edge surface, and if there is continuity when it is released.

Q: Is the stoplight switch in good condition?

YES : Check that diagnostic trouble code 14 is not output. If diagnostic trouble code 14 is output, replace the auto-cruise control-ECU. (Refer to [P.17-105.](#)) Then check that diagnostic trouble code 14 is not output.

NO : Replace the stoplight switch. Refer to GROUP 35A, Brake Pedal [P.35A-27.](#) Then check that a diagnostic trouble code 14 is not output.

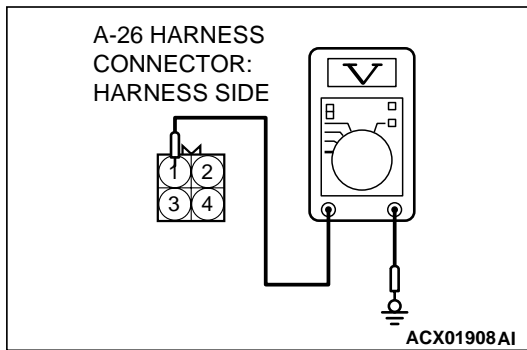
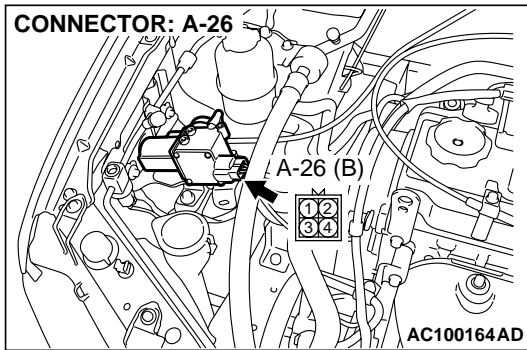

STEP 6. Measure the signal voltage at auto-cruise control vacuum pump connector A-26 by backprobing.

- (1) Do not disconnect auto-cruise control vacuum pump connector A-26.
- (2) Turn the ignition switch to the "ON" position and the auto-cruise control main switch to the "ON" position.

- (3) Measure the voltage between auto-cruise control vacuum pump connector A-26 terminal 1 and ground by backprobing.
 - The measured voltage should measure battery positive voltage. (When brake pedal is depressed).
 - The measured voltage should measure 0 V. (When brake pedal is not depressed).
- (4) Turn the ignition switch to the "LOCK" (OFF) position.

Q: Are all of the measured voltages satisfied?

YES : Go to Step 9.

NO : Go to Step 7.

STEP 7. Check auto-cruise control vacuum pump connector A-26, stoplight switch connector C-102 and intermediate connector C-111 for loose, corroded or damaged terminals, or terminals pushed back in the connector.

Q: Are the connectors and terminals in good condition?

YES : Go to Step 8.

NO : Repair or replace connector. Refer to GROUP 00E, Harness Connector Inspection [P.00E-2](#). Then check that diagnostic trouble code 14 is not output.

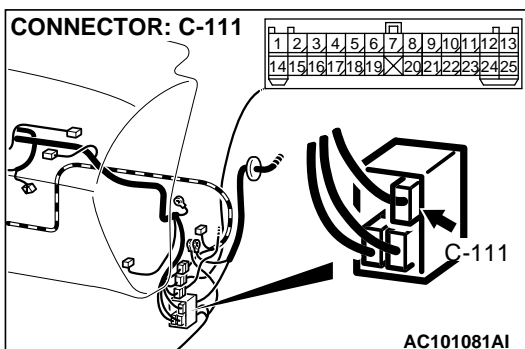
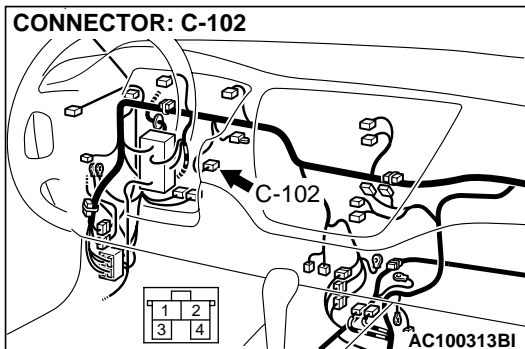
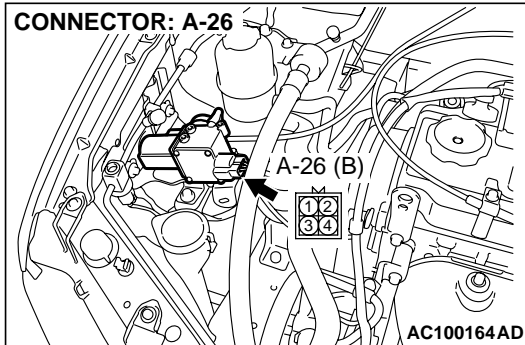

STEP 8. Check the harness auto-cruise control vacuum pump connector A-26 terminal 1 and wire between stoplight switch connector C-102 terminal 4 for damage.

Q: Is the harness wire in good condition?

- YES :** Check that diagnostic trouble code 14 is not output. If diagnostic trouble code 14 is output, replace the auto-cruise control-ECU. (Refer to [P.17-105](#)). Then check that diagnostic trouble code 14 is not output.
- NO :** Repair the harness wire and then check that diagnostic trouble code 14 is not output.

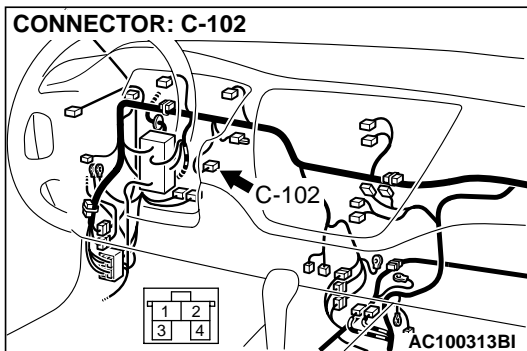
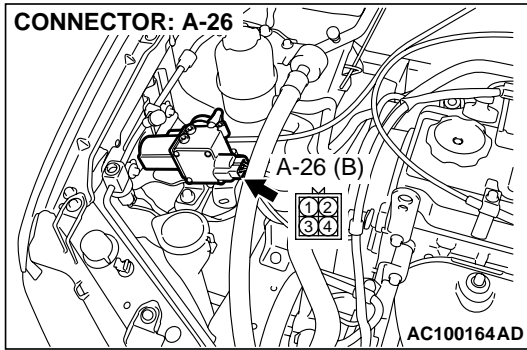

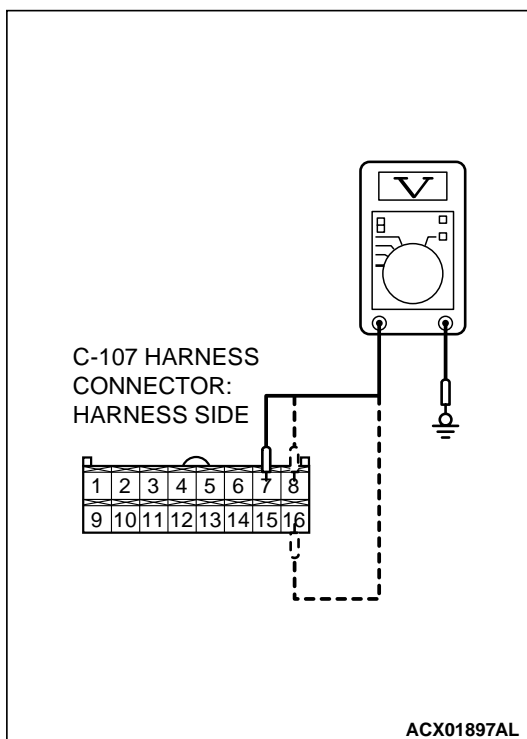
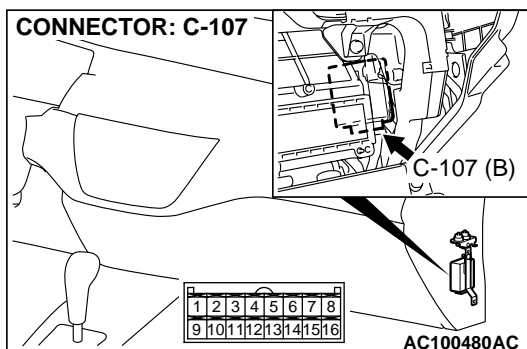

STEP 9. Measure the signal voltage at auto-cruise control-ECU connector C-107 by backprobing.

- (1) Remove the auto-cruise control-ECU mounting nut. Refer to [P.17-105](#).
- (2) Do not disconnect auto-cruise control-ECU connector C-107.
- (3) Turn the ignition switch to the "ON" position and the auto-cruise control main switch to the "ON" position.

- (4) Measure the voltage between auto-cruise control-ECU connector C-107 terminal 7 and ground by backprobing.
 - The measured voltage should measure greater than 10 V. (When cancelling constant speed driving with the auto-cruise control CANCEL switch).
- (5) Measure the voltage between auto-cruise control-ECU connector C-107 terminal 8 and ground by backprobing.
 - The measured voltage should measure greater than 10 V. (When decelerating with the auto-cruise control SET switch while driving at constant speed).
- (6) Measure the voltage between auto-cruise control-ECU connector C-107 terminal 16 and ground by backprobing.
 - The measured voltage should measure battery positive voltage. (When the motor is stopped during a constant road speed).
- (7) Turn the ignition switch to the "LOCK" (OFF) position.

Q: Are all of the measured voltages satisfied?

YES : Check that diagnostic trouble code 14 is not output. If diagnostic trouble code 14 is output, replace the auto-cruise control-ECU. (Refer to [P.17-105](#).) Then check that diagnostic trouble code 14 is not output.

NO : Go to Step 10.

STEP 10. Check auto-cruise control-ECU connector C-107 and intermediate connector C-108, C-111 for loose, corroded or damaged terminals, or terminals pushed back in the connector.

Q: Are the connectors and terminals in good condition?

YES : Go to Step 11.

NO : Repair or replace connector. Refer to GROUP 00E, Harness Connector Inspection [P.00E-2](#). Then check that diagnostic trouble code 14 is not output.

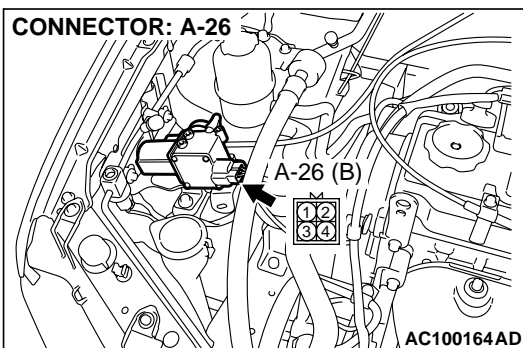
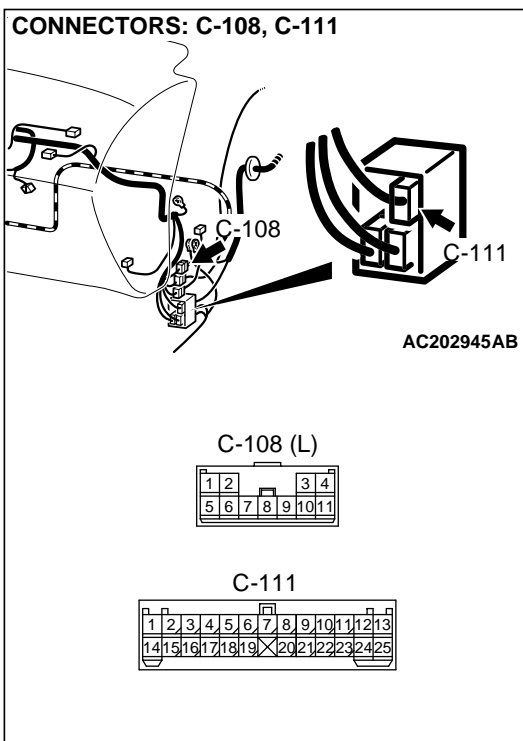
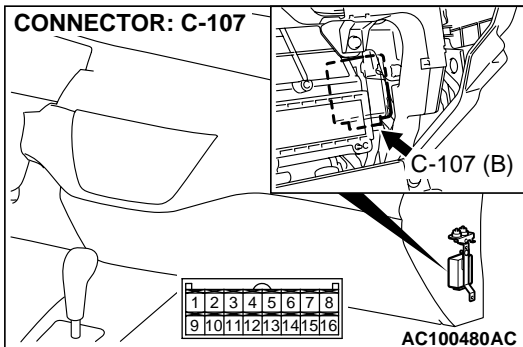

STEP 11. Check auto-cruise control vacuum pump connector A-26 for loose, corroded or damaged terminals, or terminals pushed back in the connector.

Q: Are the connector and terminals in good condition?

YES : Go to Step 12.

NO : Repair or replace connector. Refer to GROUP 00E, Harness Connector Inspection [P.00E-2](#). Then check that diagnostic trouble code 14 is not output.

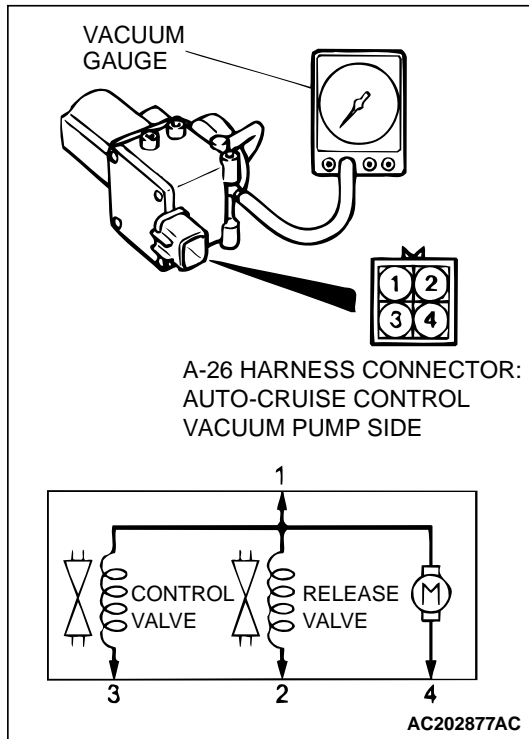
**STEP 12. Check the auto-cruise vacuum pump.**

- (1) Disconnect the vacuum hose from the auto-cruise vacuum pump and connect a vacuum gauge to the vacuum pump.
- (2) Disconnect the vacuum pump connector.
- (3) Check the auto-cruise vacuum pump and valves according to the following procedure:
 - a. Connect the positive battery terminal to auto-cruise vacuum pump connector terminal 1, and the negative battery terminal to terminals 2, 3, and 4. The vacuum gauge should read 27 kPa (8.0 in Hg) or more.
 - b. The vacuum should be maintained when terminal 4 is disconnected from the negative battery terminal while terminals 1, 2, and 3 remain connected. Then the vacuum gauge should read 0 kPa (0 in Hg) when terminal 2 is disconnected from the negative battery terminal while terminals 1, and 3 remain connected.
 - c. The vacuum should be maintained when terminal 4 is disconnected from the negative battery terminal while terminals 1, 2, and 3 remain connected. Then the vacuum gauge should read 0 kPa (0 in Hg) when terminal 3 is disconnected from the negative battery terminal while terminals 1, and 2 remain connected.

Q: Are all of the above values satisfied?**YES :** Go to Step 13.**No :** Replace the auto-cruise vacuum pump. (Refer to [P.17-105.](#)) Then check that diagnostic trouble code 14 is not output.

STEP 13. Check the harness wires between auto-cruise control vacuum pump connector A-26 terminal 2, 3, 4 and auto-cruise control-ECU connector C-107 terminal 7, 8, 16 for damage.

Q: Are the harness wires in good condition?

YES : Check that diagnostic trouble code 14 is not output. If diagnostic trouble code 14 is output, replace the auto-cruise control-ECU. (Refer to [P.17-105.](#)) Then check that diagnostic trouble code 14 is not output.

NO : Repair harness wire and then check that diagnostic trouble code 14 is not output.

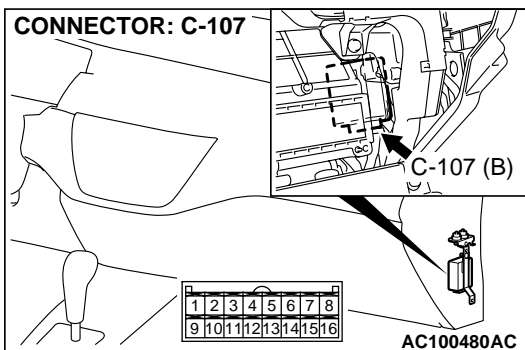
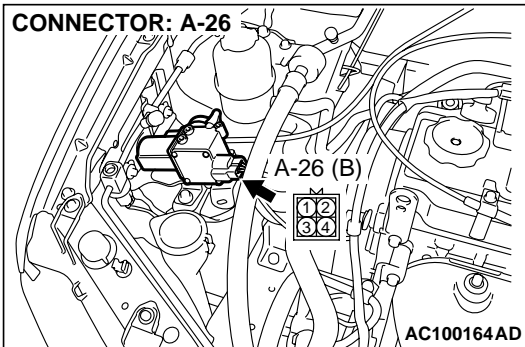

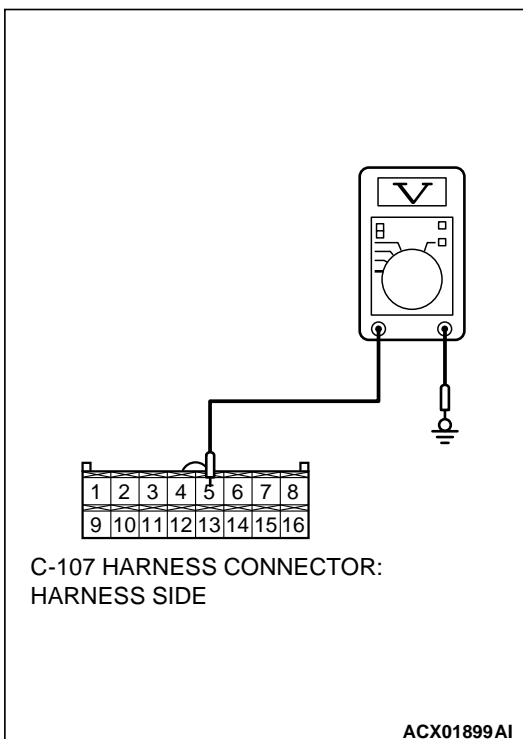
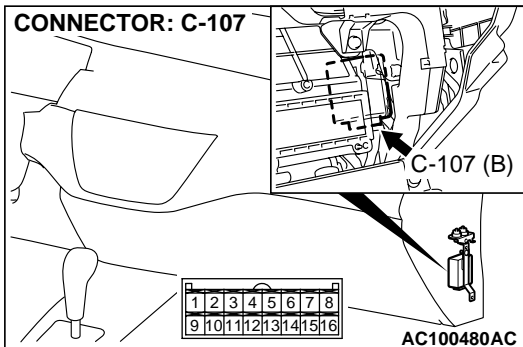

STEP 14. Measure the signal voltage at auto-cruise control-ECU connector C-107 by backprobing.

- (1) Remove the auto-cruise control-ECU mounting nut. Refer to [P.17-105](#).
- (2) Do not disconnect auto-cruise control-ECU connector C-107.
- (3) Turn the ignition switch to the "ON" position and the auto-cruise control main switch to the "ON" position.

- (4) Measure the voltage between auto-cruise control-ECU connector C-107 terminal 5 and ground by backprobing.
 - The measured voltage should measure battery positive voltage. (When brake pedal is depressed).
 - The measured voltage should measure 0 V. (When brake pedal is not depressed).
- (5) Turn the ignition switch to the "LOCK" (OFF) position.

Q: Are all of the measured voltages satisfied?

YES : Go to Step 15.

NO : Go to Step 17.

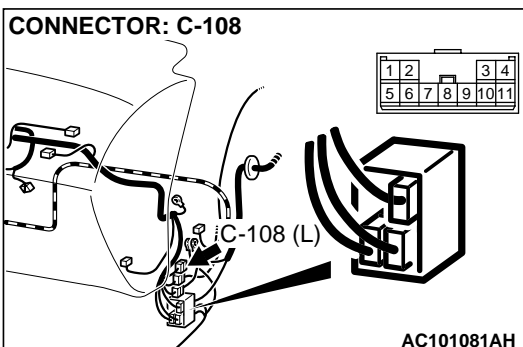

STEP 15. Check intermediate connector C-108 for loose, corroded or damaged terminals, or terminals pushed back in the connector.

Q: Are the connector and terminals in good condition?

YES : Go to Step 16.

NO : Repair or replace connector. Refer to GROUP 00E, Harness Connector Inspection [P.00E-2](#). Then check that diagnostic trouble code 14 is not output.

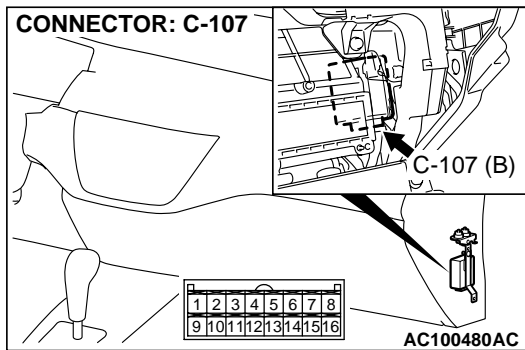
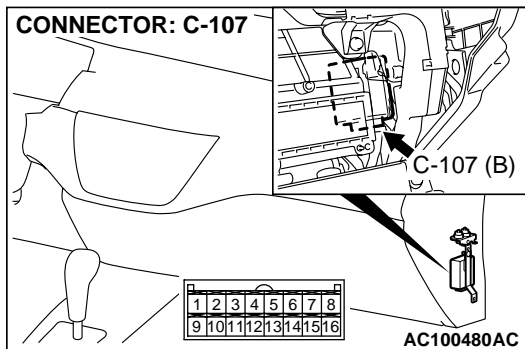
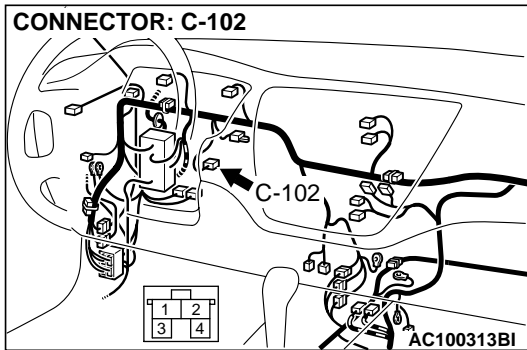

STEP 16. Check the harness wire between stoplight switch connector C-102 terminal 3 and auto-cruise control-ECU connector C-107 terminal 5 for damage.

Q: Is the harness wire in good condition?

- YES :** Check that diagnostic trouble code 14 is not output. If diagnostic trouble code 14 is output, replace the auto-cruise control-ECU. (Refer to [P.17-105](#).) Then check that diagnostic trouble code 14 is not output.
- NO :** Repair the harness wire and then check that diagnostic trouble code 14 is not output.

STEP 17. Check auto-cruise control-ECU connector C-107 for loose, corroded or damaged terminals, or terminals pushed back in the connector.

Q: Are the connector and terminals in good condition?

- YES :** Check that diagnostic trouble code 14 is not output. If diagnostic trouble code 14 is output, replace the auto-cruise control-ECU. (Refer to [P.17-105](#).) Then check that diagnostic trouble code 14 is not output.
- NO :** Repair or replace connector. Refer to GROUP 00E, Harness Connector Inspection [P.00E-2](#). Then check that diagnostic trouble code 14 is not output.

DTC15 : Auto-cruise Control Switch System

Auto-cruise Control Switch System Circuit

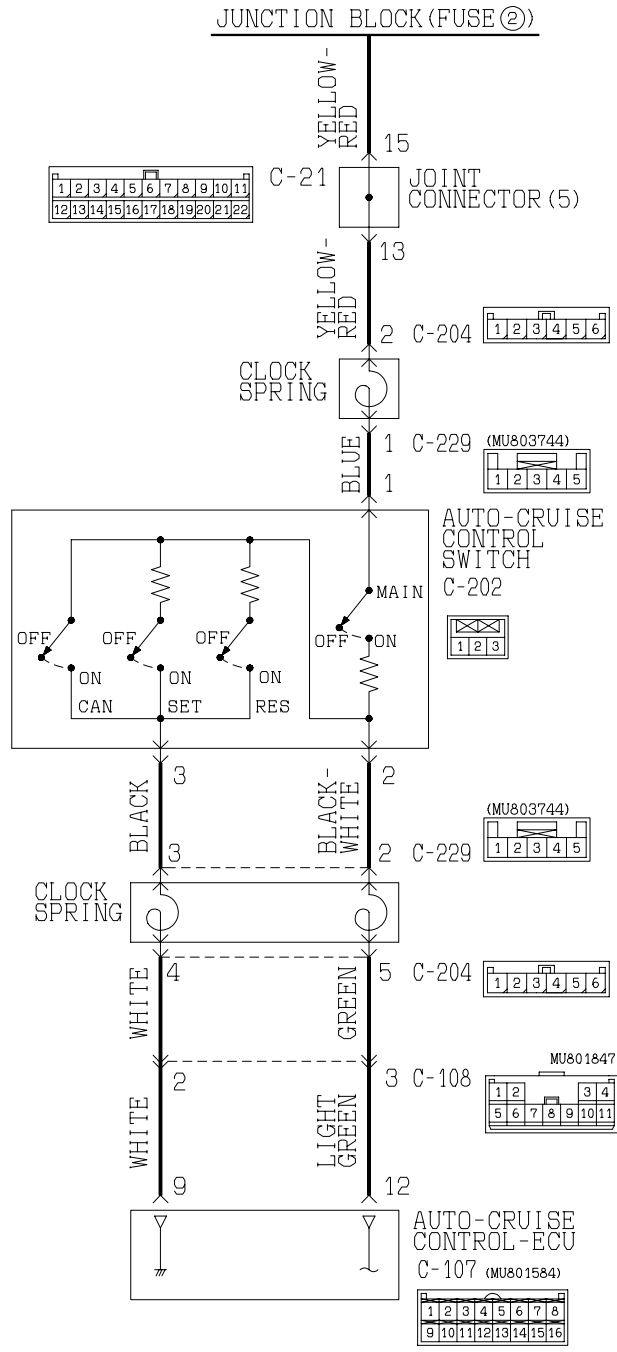

cardiagn.com

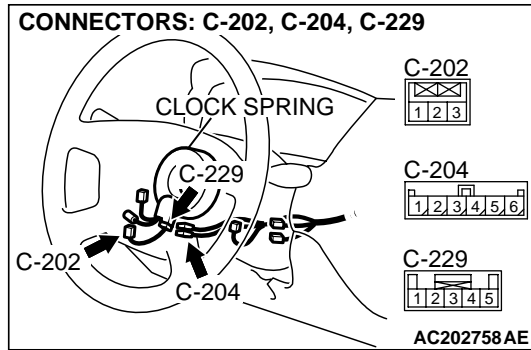
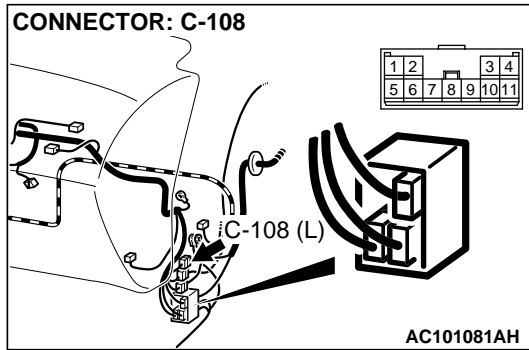
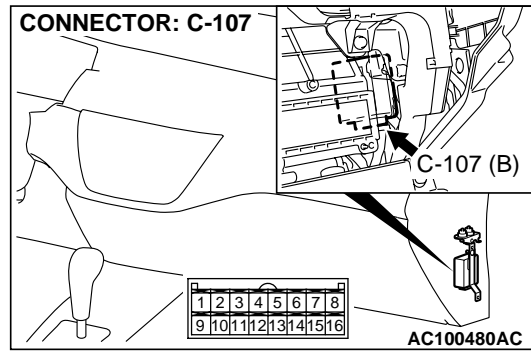
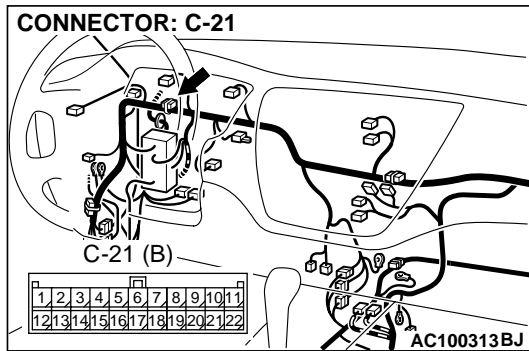

CIRCUIT OPERATION

This circuit judges the signals of each switch ("OFF," "SET," "RESUME," "CANCEL" and "MAIN") of the auto-cruise control switch. The auto-cruise control-ECU detects the state of the auto-cruise control switch by sensing the voltages shown below.

- When all switches are OFF, the ECU detects 3.5 – 5.0 volts.
- When the "SET" switch is ON, the ECU detects 0.4 – 2.3 volts.
- When the "RESUME" switch is ON, the ECU detects 2.3 – 3.5 volts.
- When the "CANCEL" switch is ON, the ECU detects 0.4 volts or less.

- When the main switch is ON, the ECU detects 7.0 volts.

DTC SET CONDITIONS

This code is output when the auto-cruise control switch "RESUME" switch, "SET" switch or "CANCEL" switch stays ON.

TROUBLESHOOTING HINTS

The most likely causes for this code to be set are:

- Malfunction of the auto-cruise control switch.
- Malfunction of the clock spring.
- Damaged harness or connector.
- Malfunction of the auto-cruise control-ECU

DIAGNOSIS**Required Special Tool:**

- MB991223: Harness Set

STEP 1. Measure the 12-Volt supply circuit voltage at auto-cruise control switch connector C-202.

- (1) Disconnect auto-cruise control switch connector C-202.
- (2) Turn the ignition switch to the "ON" position.

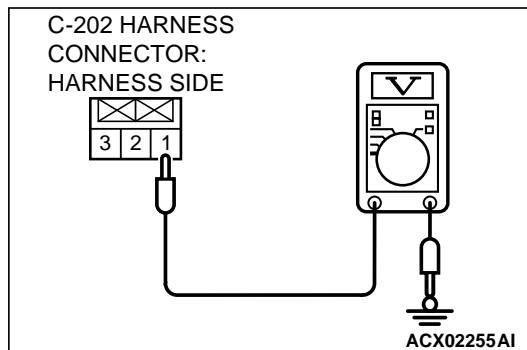
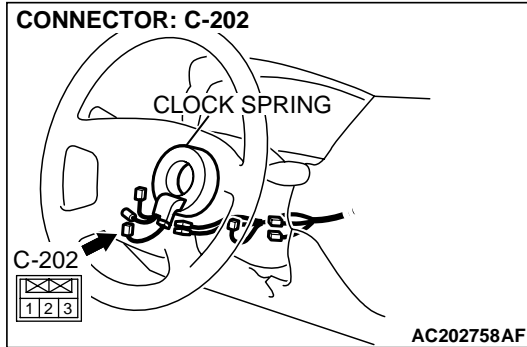

- (3) Measure the voltage between auto-cruise control switch connector C-202 terminal 1 and ground.
 - The measured voltage should measure battery positive voltage.
- (4) Turn the ignition switch to the "LOCK" (OFF) position, connect auto-cruise control switch connector C-202.

Q: Is the measured voltage battery positive voltage?

- YES** : Go to Step 6.
NO : Go to Step 2.

STEP 2. Check auto-cruise control switch connector C-202 for loose, corroded or damaged terminals, or terminals pushed back in the connector.**Q: Are the connector and terminals in good condition?**

- YES** : Go to Step 3.
NO : Repair or replace connector. Refer to GROUP 00E, Harness Connector Inspection [P.00E-2](#). Then check that diagnostic trouble code 15 is not output.

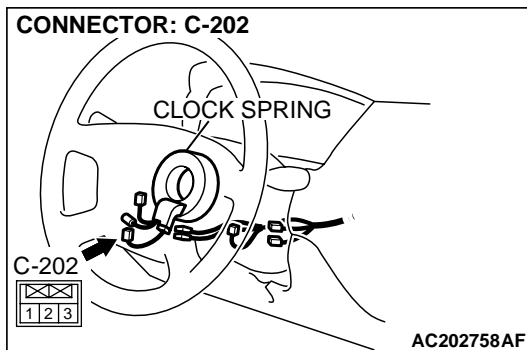
**STEP 3. Check the clock spring.**

Refer to GROUP 52B, Air Bag Modules and Clock Spring [P.52Ba-27](#).

Q: Is the clock spring in good condition?

- YES** : Go to Step 4.
NO : Replace the clock spring. Refer to GROUP 52B, Air Bag Modules and Clock Spring [P.52Ba-27](#). Then check that diagnostic trouble code 15 is not output.

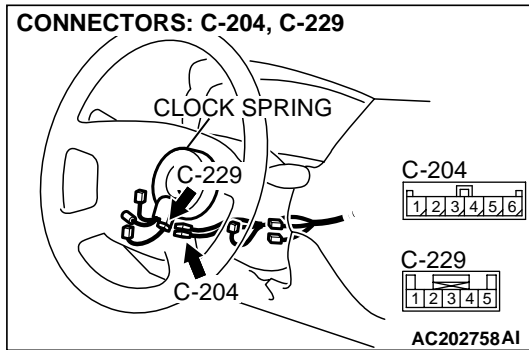

STEP 4. Check clock spring connectors C-204 and C-229 for loose, corroded or damaged terminals, or terminals pushed back in the connector.

Q: Are the connectors and terminals in good condition?

YES : Go to Step 5.

NO : Repair or replace connector. Refer to GROUP 00E, Harness Connector Inspection [P.00E-2](#). Then check that diagnostic trouble code 15 is not output.

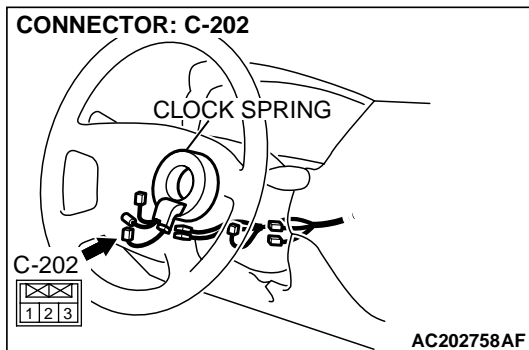

STEP 5. Check the harness wire between junction block (fuse 2) and auto-cruise control switch connector C-202 terminal 1 for damage.

Q: Is the harness wire in good condition?

YES : This malfunction is intermittent. Refer to GROUP 00, How to Use Troubleshooting/Inspection Service Points - How to Cope with Intermittent Malfunction [P.00E-2](#). Then check that diagnostic trouble code 15 is not output.

NO : Repair harness wire and then check that diagnostic trouble code 15 is not output.

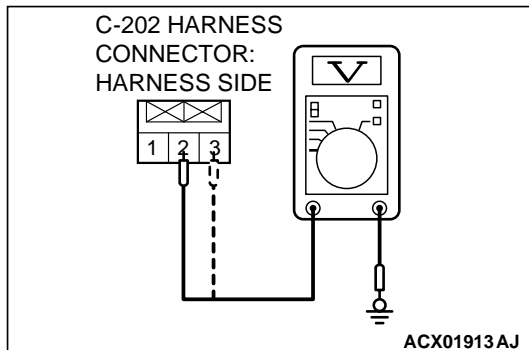
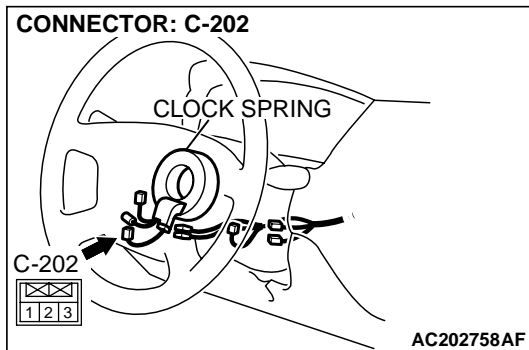

STEP 6. Measure the signal voltage at auto-cruise control switch connector C-202 by backprobing.

- (1) Do not disconnect auto-cruise control switch connector C-202.
- (2) Turn the ignition switch to the "ON" position.
- (3) Measure the voltage between auto-cruise control switch connector C-202 terminal 2 and ground by backprobing.
 - voltage should measure battery positive voltage. (MAIN switch is at the "ON" position.)
- (4) Measure the voltage between terminal 3 and ground by backprobing.
 - voltage should measure between 6.8 and 7.2 volts. (MAIN switch is at the "ON" position.)
 - voltage should measure between 3.5 and 5.0 volts. (All switches are at the "OFF" position.)
 - voltage should measure between 0.4 and 2.3 volts. ("SET" switch is at the "ON" position)
 - voltage should measure between 2.3 and 3.5 volts. ("RESUME" switch is at the "ON" position.)
 - voltage should measure between 1 volt or less. ("CANCEL" switch is at the "ON" position.)
- (5) Turn the ignition switch to the "LOCK" (OFF) position.

Q: Are all of the measured voltages satisfied?

YES : Go to Step 9.

NO : Go to Step 7.

STEP 7. Check auto-cruise control switch connector C-202 for loose, corroded or damaged terminals, or terminals pushed back in the connector.

Q: Are the connector and terminals in good condition?

YES : Go to Step 8.

NO : Repair or replace connector. Refer to GROUP 00E, Harness Connector Inspection [P.00E-2](#). Then check that diagnostic trouble code 15 is not output.

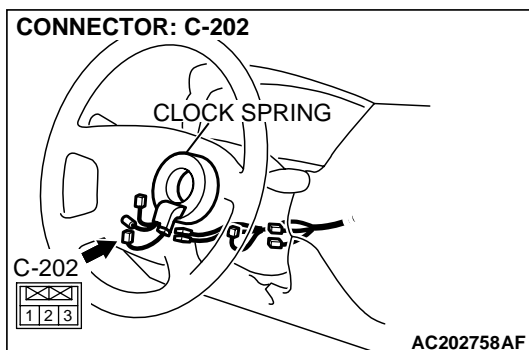

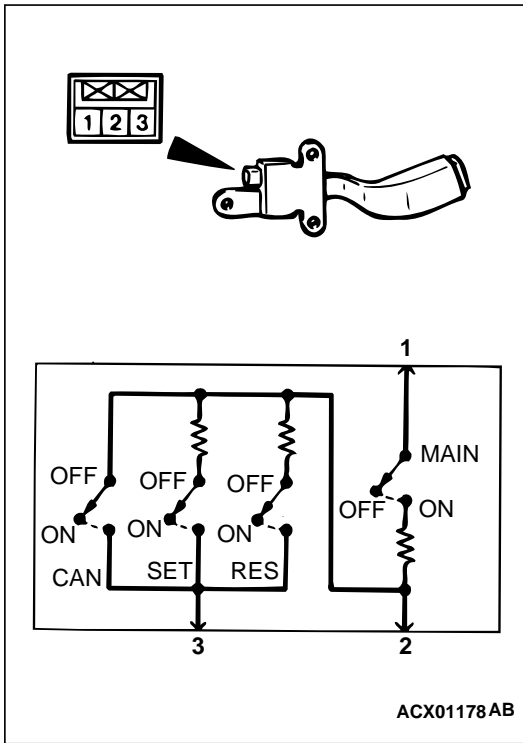

STEP 8. Check the auto-cruise control switch.

- (1) Remove the auto-cruise control switch. (Refer to P.17-105.)
- (2) Measure the resistance between the terminals when each of the SET, RESUME, CANCEL and MAIN switch is pressed.

SWITCH POSITION	RESISTANCE BETWEEN TERMINALS	
MAIN switch "OFF"	Terminal 1 and 2	Less than 2 ohms
MAIN switch "ON"	Terminal 1 and 2	Approximately 3.9 kΩ
"CANCEL" switch "ON"	Terminal 2 and 3	Approximately 0 Ω
"RESUME" switch "ON"	Terminal 2 and 3	Approximately 910 Ω
"SET" switch "ON"	Terminal 2 and 3	Approximately 220 Ω

Q: Is the measured values correspond to those in the table below?

- YES :** Check that diagnostic trouble code 15 is not output. If diagnostic trouble code 15 is output, replace the auto-cruise control-ECU. (Refer to P.17-105.) Then check that diagnostic trouble code 15 is not output.
- NO :** Replace the auto-cruise control switch. (Refer to P.17-105.) Then check that diagnostic trouble code 15 is not output.

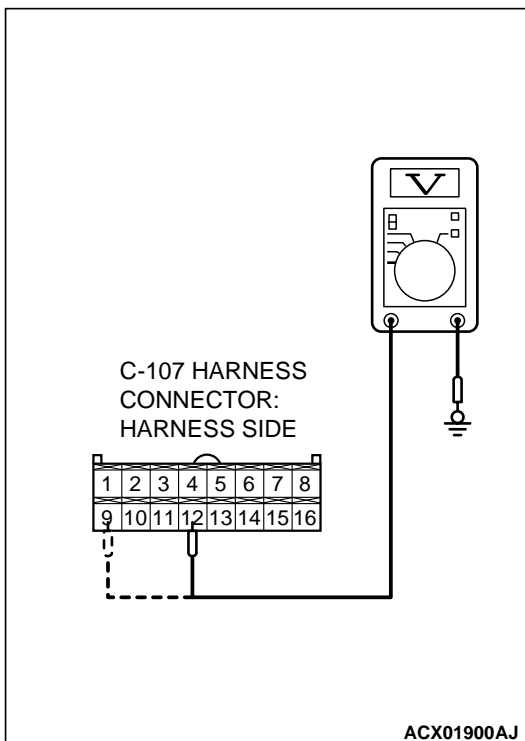
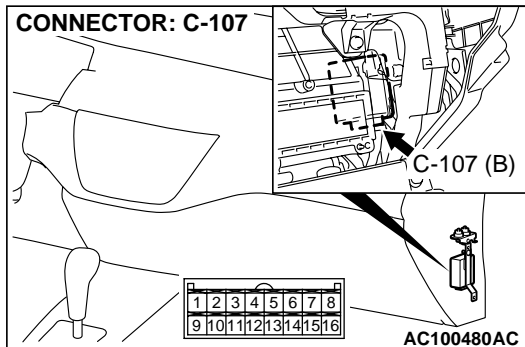

STEP 9. Measure the signal voltage at auto-cruise control-ECU connector C-107 by backprobing.

- (1) Remove the auto-cruise control-ECU mounting nut. Refer to [P.17-105](#).
- (2) Do not disconnect auto-cruise control-ECU connector C-107.
- (3) Turn the ignition switch to the "ON" position.

- (4) Measure the voltage between auto-cruise control-ECU connector C-107 terminal 12 and ground by backprobing.
 - voltage should measure battery positive voltage. (The MAIN switch is at the "ON" position.)
- (5) Measure the voltage between auto-cruise control-ECU connector C-107 terminal 9 and ground by backprobing.
 - voltage should measure between 6.8 and 7.2 volts. (MAIN switch is at the "ON" position.)
 - voltage should measure between 3.5 and 5.0 volts. (All switches are at the "OFF" position.)
 - voltage should measure between 0.4 and 2.3 volts. ("SET" switch is at the "ON" position.)
 - voltage should measure between 2.3 and 3.5 volts. ("RESUME" switch is at the "ON" position.)
 - voltage should measure between 1 volt or less. ("CANCEL" switch is at the "ON" position.)
- (6) Turn the ignition switch to the "LOCK" (OFF) position.

Q: Are all of the measured voltages satisfied?

YES : Check that diagnostic trouble code 15 is not output. If diagnostic trouble code 15 is output, replace the auto-cruise control-ECU. (Refer to [P.00E-2](#).) Then check that diagnostic trouble code 15 is not output.

NO : Go to Step 10.

STEP 10. Check auto-cruise control-ECU connector C-107 for loose, corroded or damaged terminals, or terminals pushed back in the connector.

Q: Are the connector and terminals in good condition?

YES : Go to Step 11.

NO : Repair or replace connector. Refer to GROUP 00E, Harness Connector Inspection [P.52Ba-27](#). Then check that diagnostic trouble code 15 is not output.

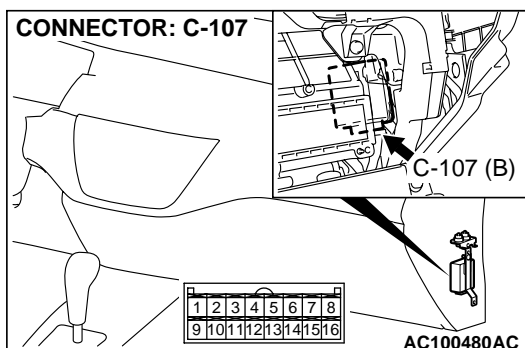

STEP 11. Check the clock spring.

Refer to GROUP 52B, Air Bag Modules and Clock Spring [P.52Ba-27](#).

Q: Is the clock spring in good condition?

YES : Go to Step 12.

NO : Replace the clock spring. Refer to GROUP 52B, Air Bag Modules and Clock Spring [P.00E-2](#). Then check that diagnostic trouble code 15 is not output.

STEP 12. Check auto-cruise control switch connector C-202, clock spring connectors C-204 and C-229 for loose, corroded or damaged terminals, or terminals pushed back in the connector.

Q: Are the connectors and terminals in good condition?

YES : Go to Step 13.

NO : Repair or replace connector. Refer to GROUP 00E, Harness Connector Inspection [P.17-105](#). Then check that diagnostic trouble code 15 is not output.

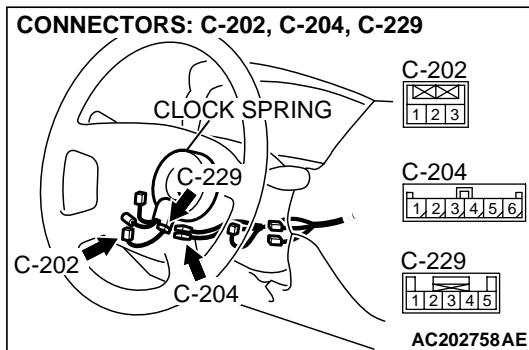

STEP 13. Check the harness wires between auto-cruise control switch connector C-202 terminal 2, 3 and auto-cruise control-ECU connector C-107 terminal 12, 9 for damage.

Q: Are the harness wires in good condition?

YES : Check that diagnostic trouble code 15 is not output. If diagnostic trouble code 15 is output, replace the auto-cruise control-ECU. (Refer to [P.17-105](#).) Then check that diagnostic trouble code 15 is not output.

NO : Repair harness wire and then check that diagnostic trouble code 15 is not output.

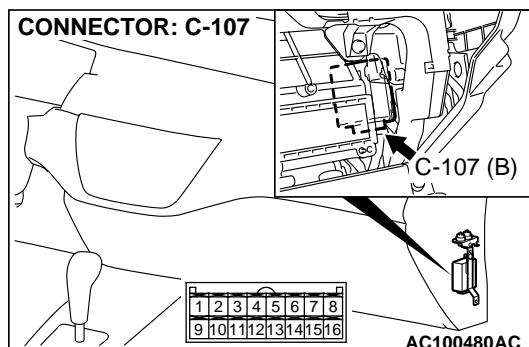
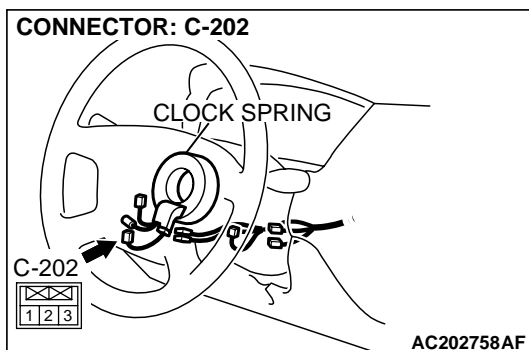

DTC 16: Auto-cruise Control-ECU

DTC SET CONDITIONS

This code is output when a problem is found on the cancel status hold circuit or microcomputer operation monitor circuit, which is incorporated in the auto-cruise control-ECU.

TROUBLESHOOTING HINTS

Malfunction of the auto-cruise control-ECU.

DIAGNOSIS

Replace the auto-cruise control-ECU. (Refer to P.17-105.)
 Check that diagnostic trouble code 16 is not output.

DTC 17: Throttle Position Sensor and Idle Position Signal System <M/T>

Throttle Position Sensor and Idle Position Signal System Circuit

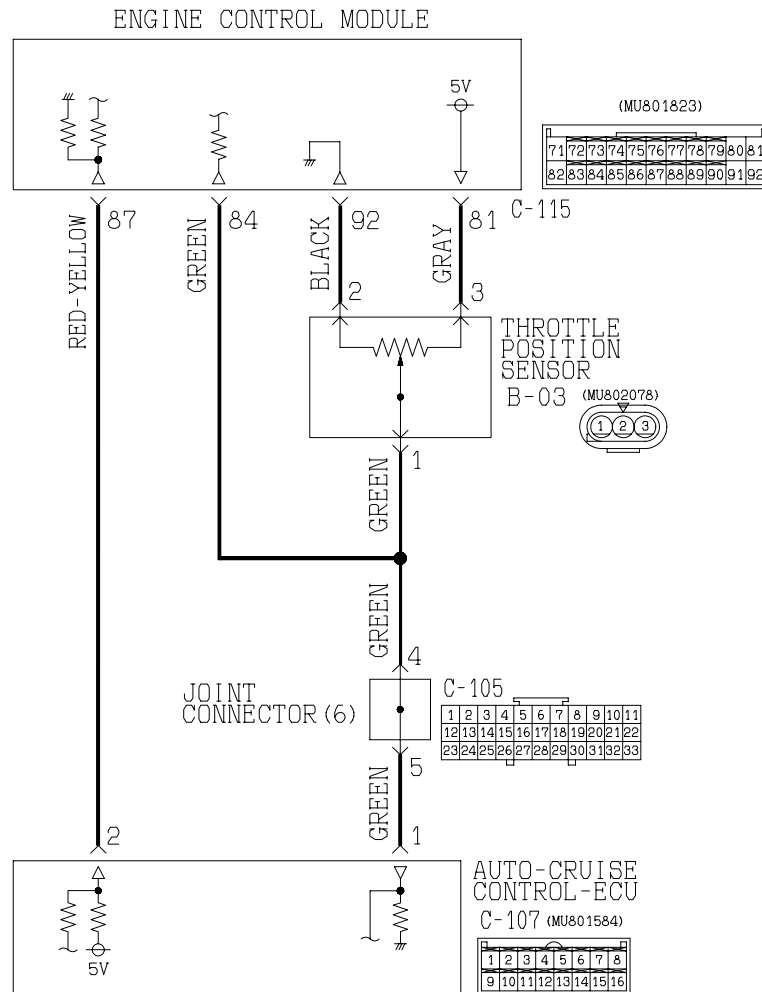

AC203544 AB

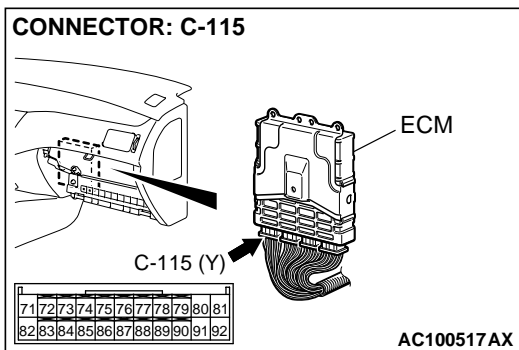
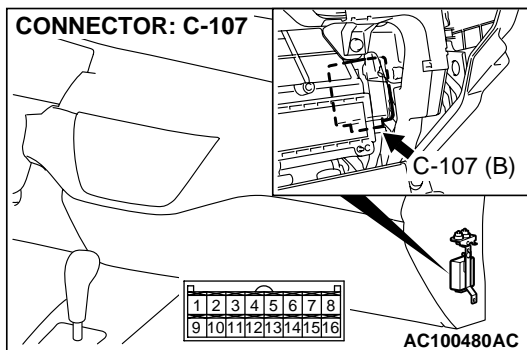
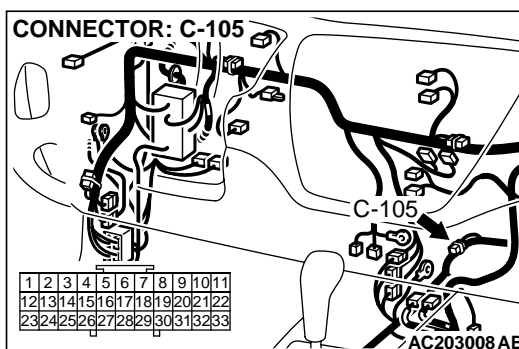
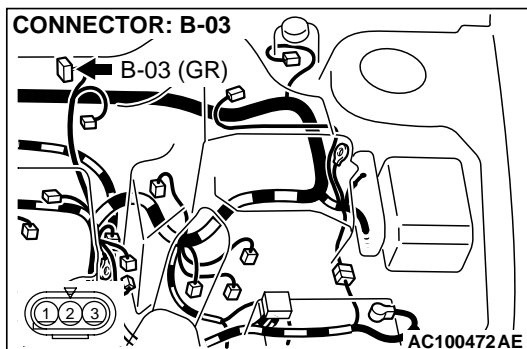

CIRCUIT OPERATION

The throttle position sensor signal and idle position signal are sent to the auto-cruise control-ECU through this circuit.

The throttle position sensor sends a voltage signal to terminal 1 of the auto-cruise control-ECU. The voltage depends on throttle opening angle.

The auto-cruise control-ECU receives an idle position signal from the ECM at terminal 2. The signal is OFF when the accelerator pedal is depressed, and ON when the accelerator pedal is released.

DTC SET CONDITIONS

- The Idle position signal is ON and the throttle position sensor voltage is 2.5 volts or more for four seconds or more.
- The Idle position signal is OFF and the throttle position sensor voltage is 0.2 volts or less for four seconds or more.

TROUBLESHOOTING HINTS

The most likely causes for this code to be set are:

- Malfunction of the throttle position sensor.
- Damaged harness or connector.
- Malfunction of the auto-cruise control-ECU.
- Malfunction of the ECM.

cardiagn.com

DIAGNOSIS**Required Special Tools:**

- MB991502: Scan Tool (MUT-II)
- MB991223: Harness Set

STEP 1. Check the throttle position sensor.**⚠ CAUTION**

To prevent damage to scan tool MB991502, always turn the ignition switch to the "LOCK" (OFF) position before connecting or disconnecting scan tool MB991502.

- (1) Using scan tool MB991502.
- (2) Connect scan tool MB991502 to the data link connector.
- (3) Turn the ignition switch to the "ON" position.
- (4) Read the MFI-DTC.
- (5) Turn the ignition switch to the "LOCK" (OFF) position.

Q: Is the MFI-DTC P0121, P0122 or P0123 is output?

YES : Refer to GROUP 13A, Diagnosis – Diagnostic Trouble Code Chart [P.13Ab-22](#).

NO : Go to Step 2.

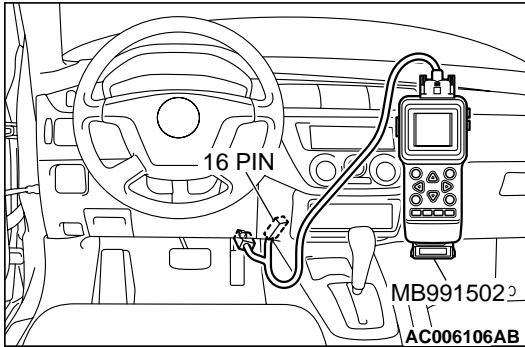

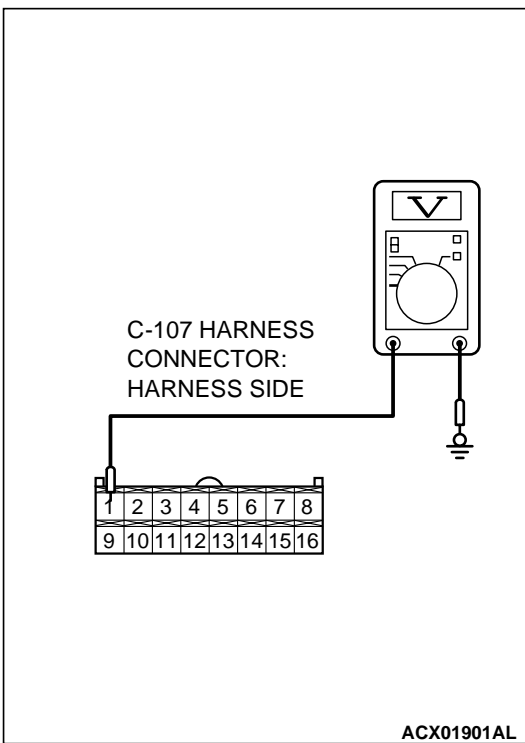
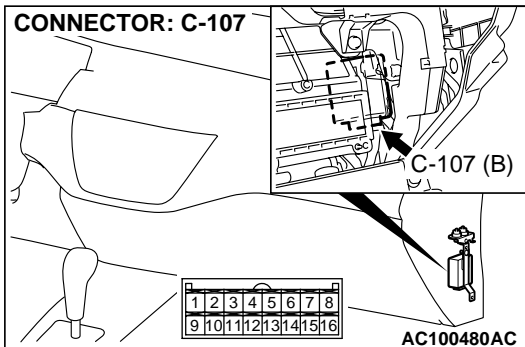

STEP 2. Measure the signal voltage at auto-cruise control-ECU connector C-107 by backprobing.

- (1) Remove the auto-cruise control-ECU mounting nut. Refer to [P.17-105](#).
- (2) Do not disconnect auto-cruise control-ECU connector C-107.
- (3) Turn the ignition switch to the "ON" position and the auto-cruise control MAIN switch to the "ON" position.

- (4) Measure the voltage between auto-cruise control-ECU connector C-107 terminal 1 and ground by backprobing.
 - The measure voltage should measure between 4.0 and 5.5 volts. (When accelerator pedal is fully depressed.)
 - The measure voltage should measure between 0.4 and 1.0 volts. (When accelerator pedal is released.)
- (5) Turn the auto-cruise control MAIN switch to the "OFF" position and the ignition switch to the "LOCK" (OFF) position.

Q: Are all of the measured voltages satisfied?

YES : Go to Step 5.

NO : Go to Step 3.

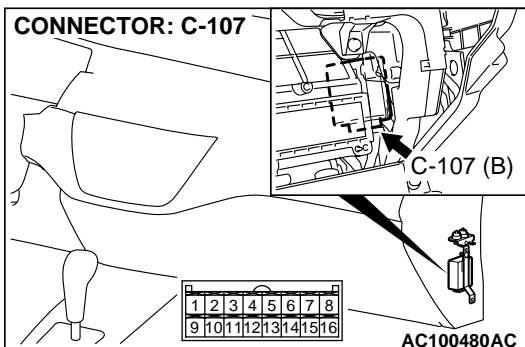

STEP 3. Check auto-cruise control-ECU connector C-107 for loose, corroded or damaged terminals, or terminals pushed back in the connector.

Q: Are the connector and terminals in good condition?

YES : Go to Step 4.

NO : Repair or replace connector. Refer to GROUP 00E, Harness Connector Inspection [P.00E-2](#). Then check that diagnostic trouble code 17 is not output.

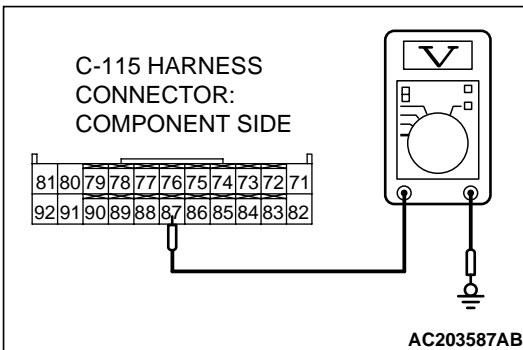
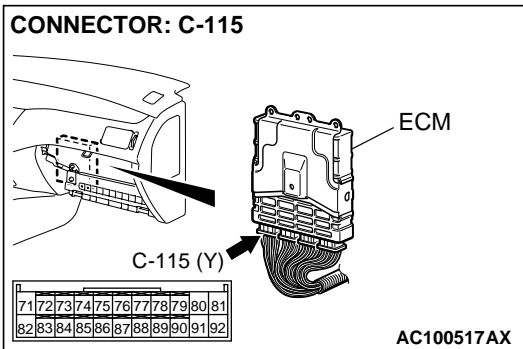
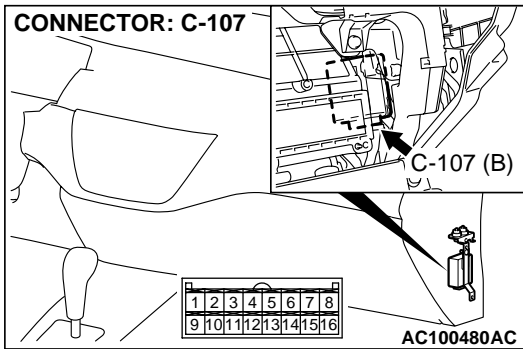
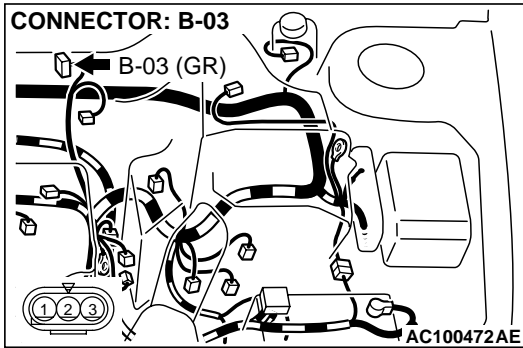

STEP 4. Check the harness wire between throttle position sensor connector B-03 terminal 1 and auto-cruise control-ECU connector C-107 terminal 1 for damage.

Q: Is the harness wire in good condition?

- YES :** Check that diagnostic trouble code 17 is not output. If diagnostic trouble code 17 is output, replace the auto-cruise control-ECU. (Refer to P.17-105.) Then check that diagnostic trouble code 17 is not output.
- NO :** Repair harness wire and then check that diagnostic trouble code 17 is not output.

STEP 5. Measure the signal voltage at ECM connector C-115.

- (1) Disconnect ECM connector C-115.
- (2) Turn the ignition switch to the "ON" position and the auto-cruise control MAIN switch to the "ON" position.

- (3) Measure the voltage between ECM connector C-115 terminal 87 and ground.
 - The measured voltage should measure between 4.0 and 5.5 volts.
- (4) Turn the auto-cruise control MAIN switch to the "OFF" position and the ignition switch to the "LOCK" (OFF) position.

Q: Is the measured voltage between 4.0 and 5.5 volts?

- YES :** Check that diagnostic trouble code 17 is not output. If diagnostic trouble code 17 is output, replace the ECM. Then check that diagnostic trouble code 17 is not output.
- NO :** Go to Step 6.

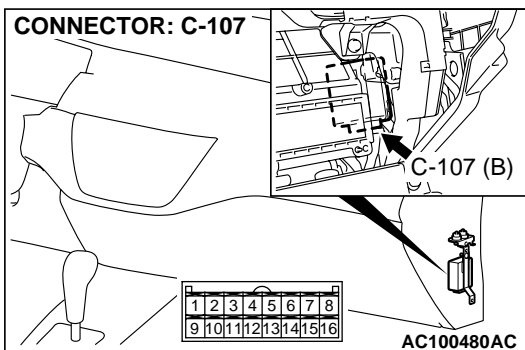
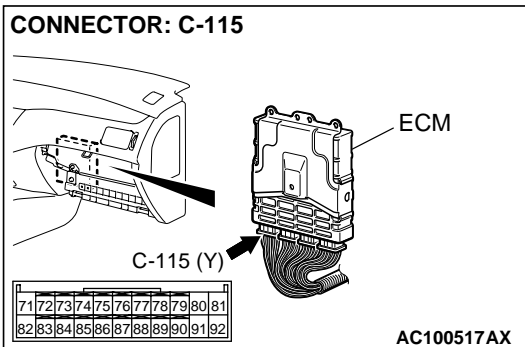

STEP 6. Check ECM connector C-115 and auto-cruise control-ECU connector C-107 for loose, corroded or damaged terminals, or terminals pushed back in the connector.

Q: Are the connectors and terminals in good condition?

YES : Go to Step 7.

NO : Repair or replace connector. Refer to GROUP 00E, Harness Connector Inspection P.00E-2. Then check that diagnostic trouble code 17 is not output.

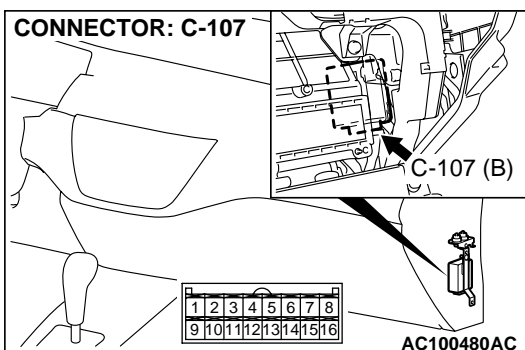
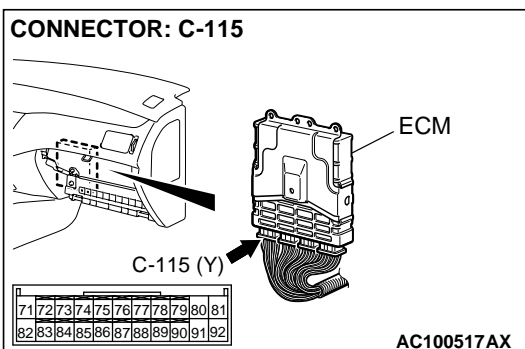

STEP 7. Check the harness wire between ECM connector C-115 terminal 87 and auto-cruise control-ECU connector C-107 terminal 2 for damage.

Q: Is the harness wire in good condition?

YES : Go to Step 8.

NO : Repair harness wire and then check that diagnostic trouble code 17 is not output.

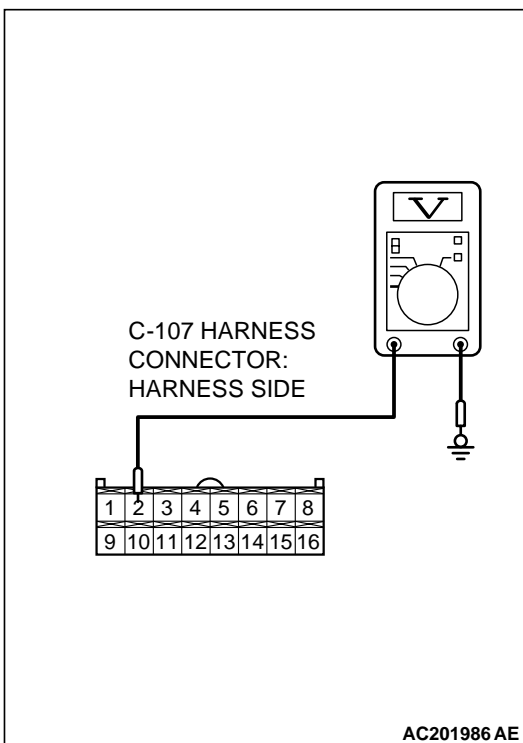
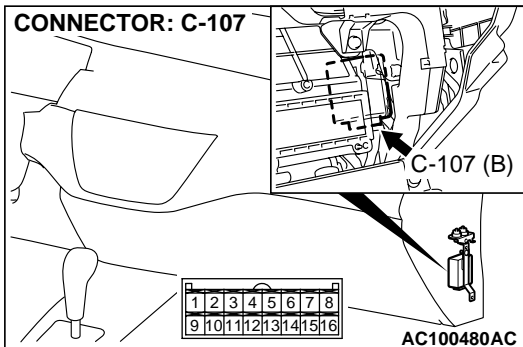

STEP 8. Measure the signal voltage at auto-cruise control-ECU connector C-107 by backprobing.

- (1) Remove the auto-cruise control-ECU mounting nut. Refer to [P.17-105](#).
- (2) Do not disconnect auto-cruise control-ECU connector C-107.
- (3) Turn the ignition switch to the "ON" position and the auto-cruise control MAIN switch to the "ON" position.

- (4) Measure the voltage between auto-cruise control-ECU connector C-107 terminal 2 and ground by backprobing.
 - The measured voltage should measure between 4.0 and 5.5 volts. (When accelerator pedal is depressed.)
 - The measured voltage should measure between 2.5 volts or less. (When accelerator pedal is released.)
- (5) Turn the auto-cruise control MAIN switch to the "OFF" position and the ignition switch to the "LOCK" (OFF) position.

Q: Are all of the measured voltages satisfied?

YES : Check that diagnostic trouble code 17 is not output. If diagnostic trouble code 17 is output, replace the auto-cruise control-ECU. (Refer to [P.00E-2](#).) Then check that diagnostic trouble code 17 is not output.

NO : Replace the auto-cruise control-ECU (Refer to [P.17-105](#)). Then check that diagnostic trouble code 17 is not output.

DTC 17: Throttle Position Sensor and Idle Position Signal System <A/T>

Throttle Position Sensor and Idle Position Signal System Circuit

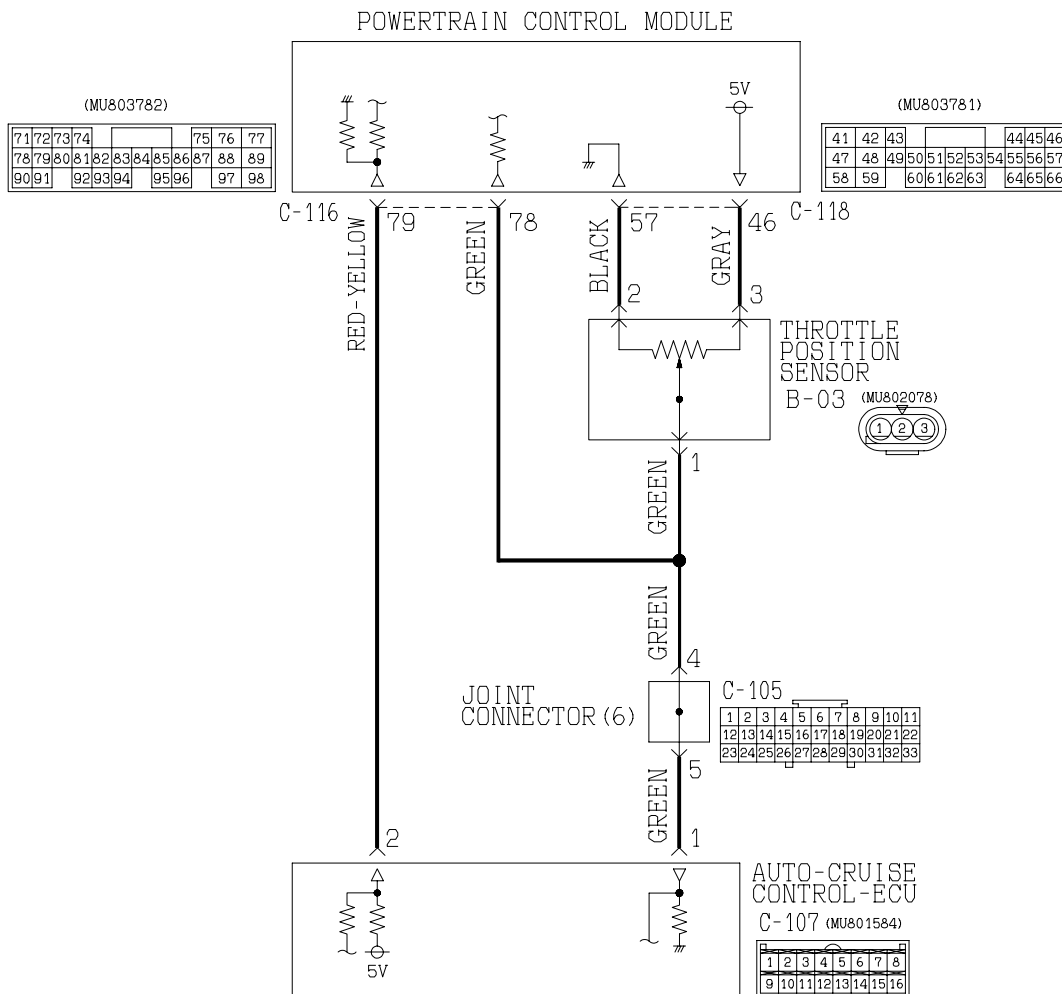

AC203545 AB

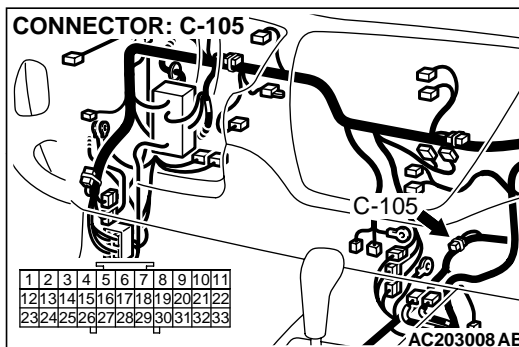
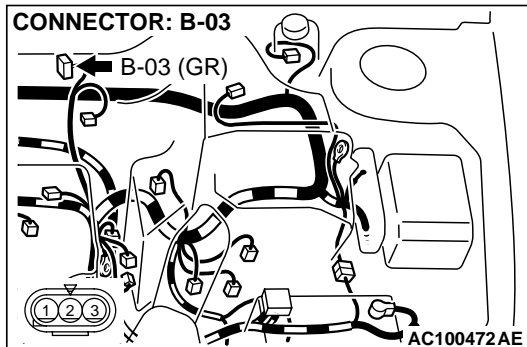

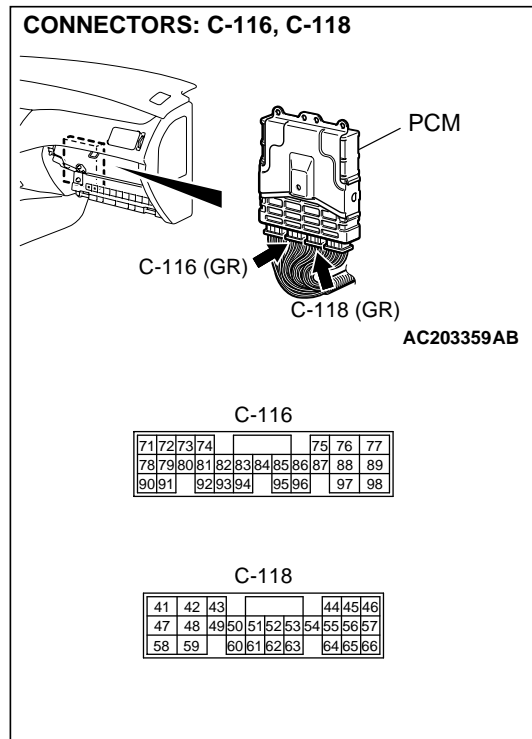
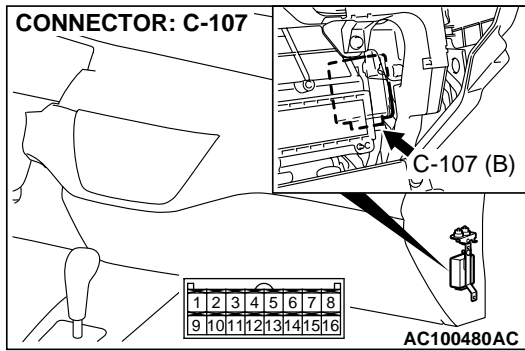

CIRCUIT OPERATION

The throttle position sensor signal is sent to the auto-cruise control-ECU through this circuit. The auto-cruise control-ECU receives a signal from the throttle position sensor at terminal 1. The signal is OFF when the accelerator pedal is depressed, and ON when the accelerator pedal is released. The throttle position sensor sends a voltage signal to terminal 1 of the auto-cruise control-ECU. The voltage depends on throttle opening angle.

DTC SET CONDITIONS

If 2.5 volts or more 0.2 volts or less is output for four seconds or more.

TROUBLESHOOTING HINTS

The most likely causes for this code to be set are:

- Malfunction of the throttle position sensor.
- Damaged harness or connector.
- Malfunction of the auto-cruise control-ECU.
- Malfunction of the PCM.

DIAGNOSIS

Required Special Tools:

- MB991502: Scan Tool (MUT-II)
- MB991223: Harness Set

STEP 1. Check the throttle position sensor.

CAUTION

To prevent damage to scan tool MB991502, always turn the ignition switch to the "LOCK" (OFF) position before connecting or disconnecting scan tool MB991502.

- (1) Using scan tool MB991502.
- (2) Connect scan tool MB991502 to the data link connector.
- (3) Turn the ignition switch to the "ON" position.
- (4) Read the MFI-DTC.
- (5) Turn the ignition switch to the "LOCK" (OFF) position.

Q: Is the MFI-DTC P0121, P0122 or P0123 is output?

YES : Refer to GROUP 13A, Diagnosis – Diagnostic Trouble Code Chart P.13Ab-22.

NO : Go to Step 2.

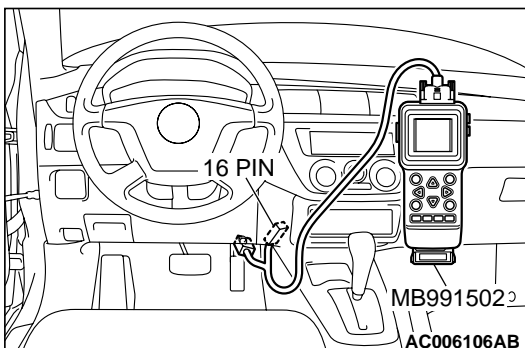

STEP 2. Measure the signal voltage at auto-cruise control-ECU connector C-107 by backprobing.

- (1) Remove the auto-cruise control-ECU mounting nut. Refer to [P.17-105](#).
- (2) Do not disconnect auto-cruise control-ECU connector C-107.
- (3) Turn the ignition switch to the "ON" position and the auto-cruise control MAIN switch to the "ON" position.

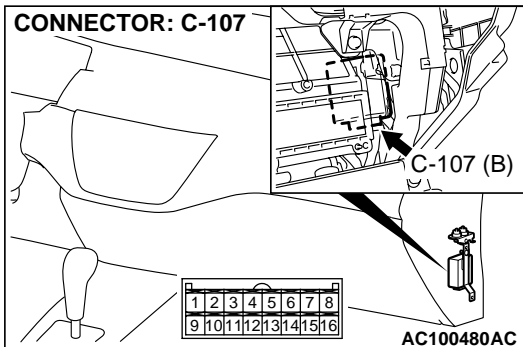

- (4) Measure the voltage between auto-cruise control-ECU connector C-107 terminal 1 and ground by backprobing.
 - The measure voltage should measure between 4.0 and 5.5 volts. (When accelerator pedal is fully depressed.)
 - The measure voltage should measure between 0.4 and 1.0 volts. (When accelerator pedal is released.)
- (5) Turn the auto-cruise control MAIN switch to the "OFF" position and the ignition switch to the "LOCK" (OFF) position.

Q: Are all of the measured voltages satisfied?

YES : Go to Step 5.

NO : Go to Step 3.

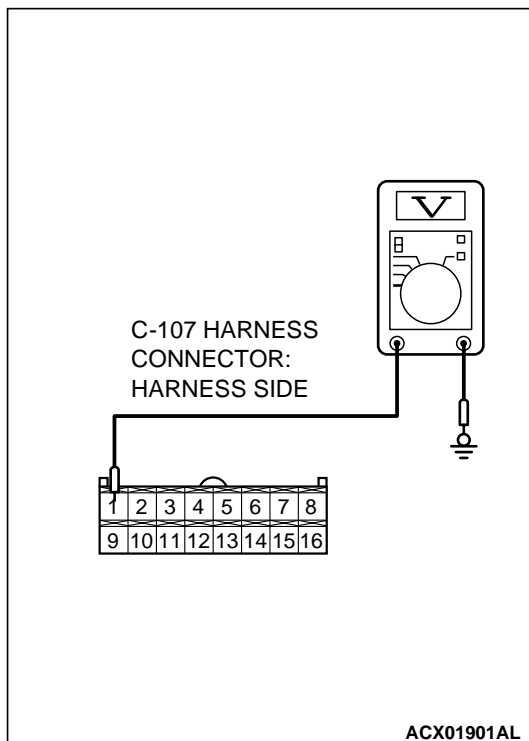

STEP 3. Check auto-cruise control-ECU connector C-107 for loose, corroded or damaged terminals, or terminals pushed back in the connector.

Q: Are the connector and terminals in good condition?

YES : Go to Step 4.

NO : Repair or replace connector. Refer to GROUP 00E, Harness Connector Inspection [P.00E-2](#). Then check that diagnostic trouble code 17 is not output.

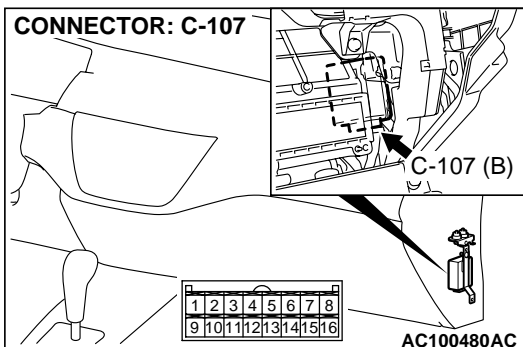

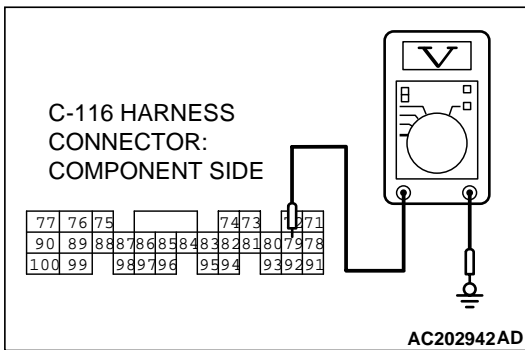
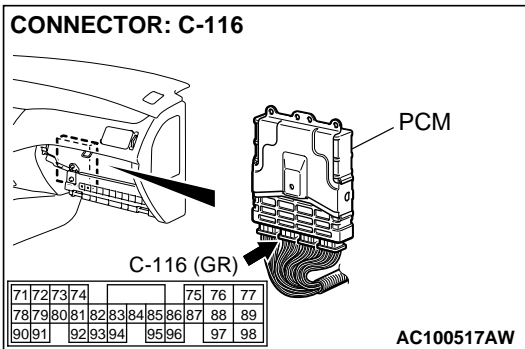
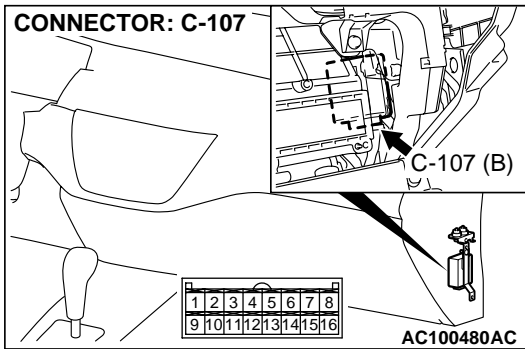
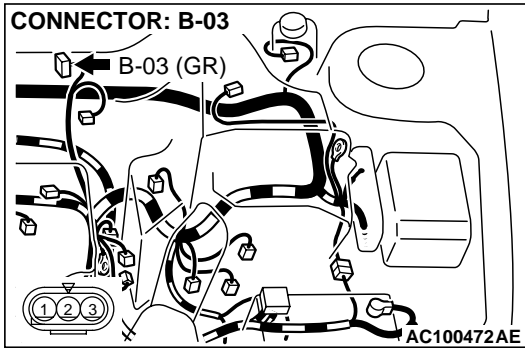

STEP 4. Check the harness wire between throttle position sensor connector B-03 terminal 1 and auto-cruise control-ECU connector C-107 terminal 1 for damage.

Q: Is the harness wire in good condition?

- YES :** Check that diagnostic trouble code 17 is not output. If diagnostic trouble code 17 is output, replace the auto-cruise control-ECU. (Refer to P.17-105.) Then check that diagnostic trouble code 17 is not output.
- NO :** Repair harness wire and then check that diagnostic trouble code 17 is not output.

STEP 5. Measure the signal voltage at PCM connector C-116.

- (1) Disconnect PCM connector C-116.
- (2) Turn the ignition switch to the "ON" position and the auto-cruise control MAIN switch to the "ON" position.

- (3) Measure the voltage between PCM connector C-116 terminal 79 and ground.
 - The measured voltage should measure between 4.0 and 5.5 volts.
- (4) Turn the auto-cruise control MAIN switch to the "OFF" position and the ignition switch to the "LOCK" (OFF) position.

Q: Is the measured voltage between 4.0 and 5.5 volts?

- YES :** Check that diagnostic trouble code 17 is not output. If diagnostic trouble code 17 is output, replace the PCM. Then check that diagnostic trouble code 17 is not output.
- NO :** Go to Step 6.

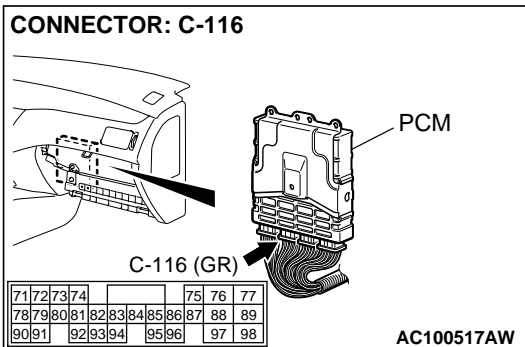

STEP 6. Check PCM connector C-116 and auto-cruise control-ECU connector C-107 for loose, corroded or damaged terminals, or terminals pushed back in the connector.

Q: Are the connectors and terminals in good condition?

YES : Go to Step 7.

NO : Repair or replace connector. Refer to GROUP 00E, Harness Connector Inspection P.00E-2. Then check that diagnostic trouble code 17 is not output.

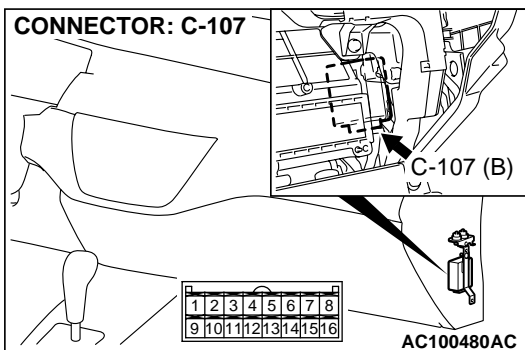

STEP 7. Check the harness wire between PCM connector C-116 terminal 79 and auto-cruise control-ECU connector C-107 terminal 2 for damage.

Q: Is the harness wire in good condition?

YES : Go to Step 8.

NO : Repair harness wire and then check that diagnostic trouble code 17 is not output.

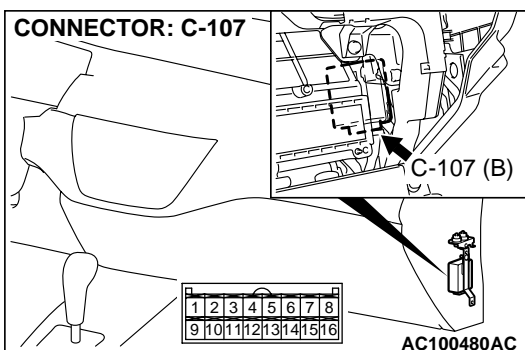
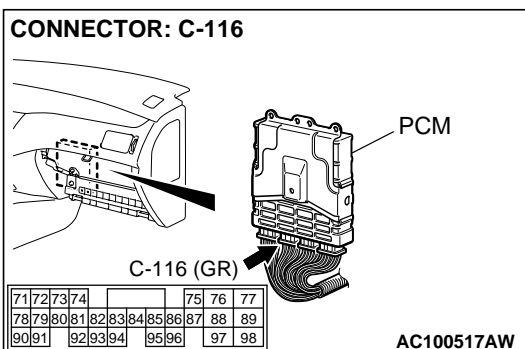

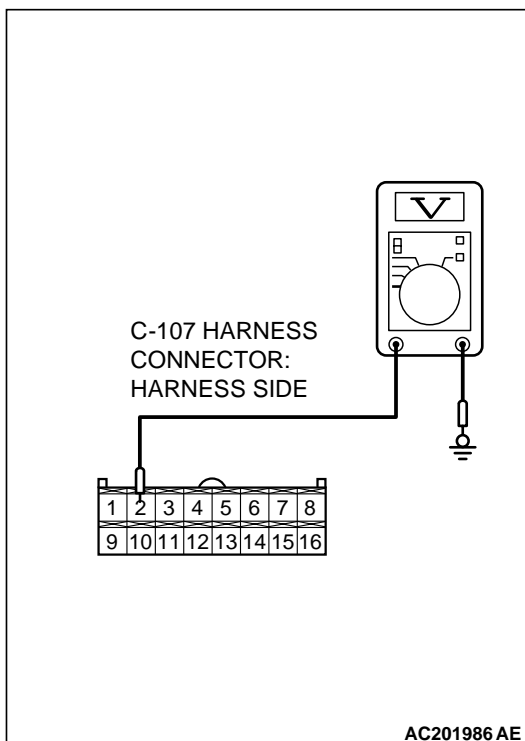
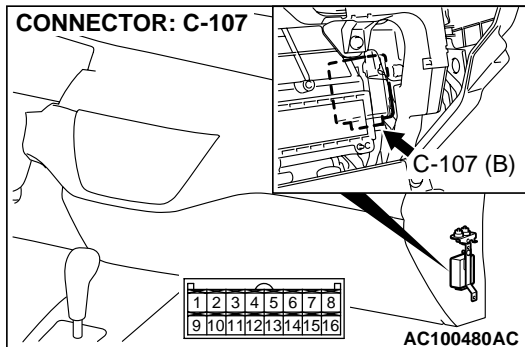

STEP 8. Measure the signal voltage at auto-cruise control-ECU connector C-107 by backprobing.

- (1) Remove the auto-cruise control-ECU mounting nut. Refer to [P.17-105](#).
- (2) Do not disconnect auto-cruise control-ECU connector C-107.
- (3) Turn the ignition switch to the "ON" position and the auto-cruise control MAIN switch to the "ON" position.

- (4) Measure the voltage between auto-cruise control-ECU connector C-107 terminal 2 and ground by backprobing.
 - The measured voltage should measure between 4.0 and 5.5 volts. (When accelerator pedal is depressed.)
 - The measured voltage should measure between 2.5 volts or less. (When accelerator pedal is released.)
- (5) Turn the auto-cruise control MAIN switch to the "OFF" position and the ignition switch to the "LOCK" (OFF) position.

Q: Are all of the measured voltages satisfied?

YES : Check that diagnostic trouble code 17 is not output. If diagnostic trouble code 17 is output, replace the auto-cruise control-ECU. (Refer to [P.00E-2](#).) Then check that diagnostic trouble code 17 is not output.

NO : Replace the auto-cruise control-ECU (Refer to [P.17-105](#)). Then check that diagnostic trouble code 17 is not output.

SYMPTOM CHART

M1172002300258

SYMPTOMS		INSPECTION PROCEDURE NO.	REFERENCE PAGE
Communication with scan tool MB991502 is not possible	Communication with all systems is not possible	-	P.13Ad-2
	Communication with auto-cruise control-ECU only is not possible	1	P.13Ad-5
Auto-cruise control is not cancelled.	When brake pedal is depressed	2	P.17-66
	When clutch pedal is depressed <M/T>	3	P.17-74
	When selector lever is moved to "N" range <A/T>	4	P.17-79
	When "CANCEL" switch is turned ON	5	P.17-84
Auto-cruise control cannot be set.		6	P.17-84
Hunting (repeated acceleration and deceleration) occurs at the set vehicle speed.		7	<M/T> P.17-86 <A/T> P.17-88
Auto-cruise control indicator light inside combination meter does not illuminate. (However, auto-cruise control is normal.)		8	P.17-90

cardiagn.com

SYMPTOM PROCEDURES

**INSPECTION PROCEDURE 1: Communication With Scan Tool MB991502 is not Possible
 (Communication with the Auto-cruise Control-ECU Only is not Possible.)**

Auto-cruise Control-ECU Supply, Ground and Data Link Circuit

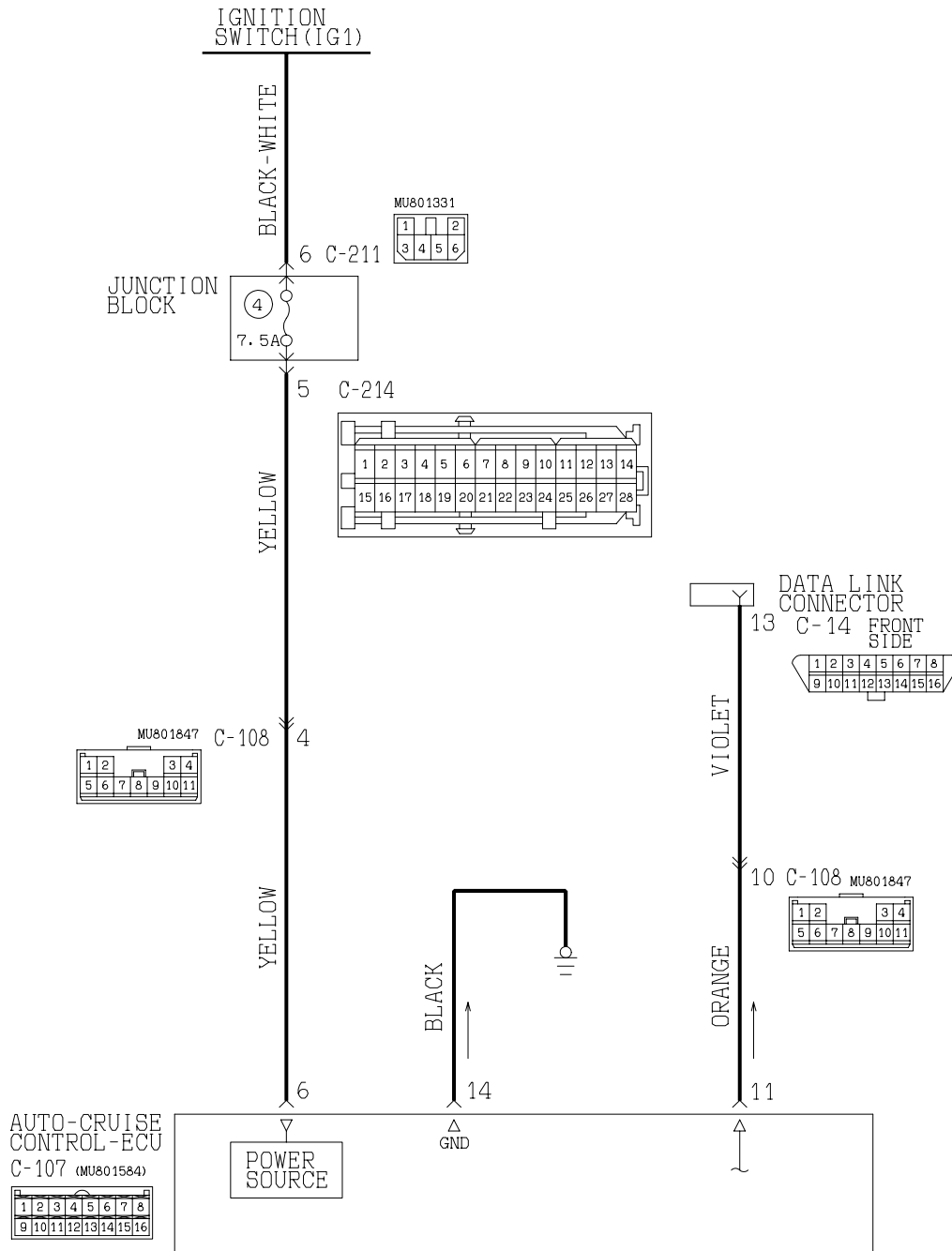

cardiagn.com

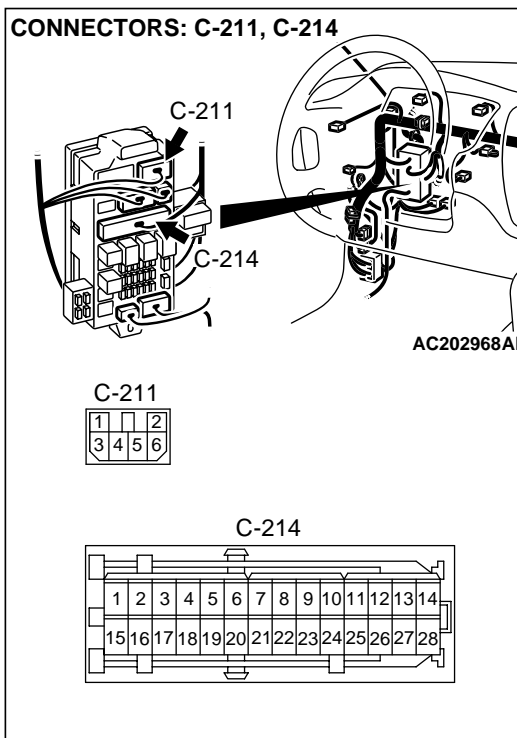
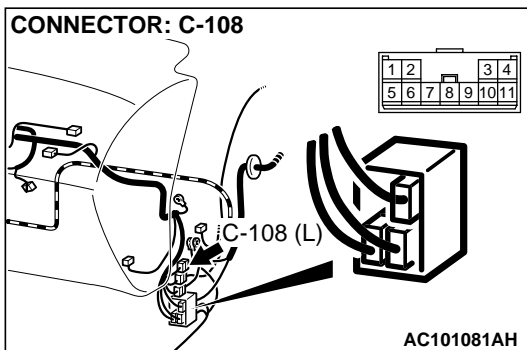
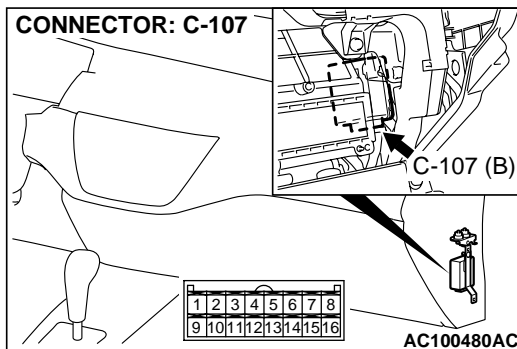
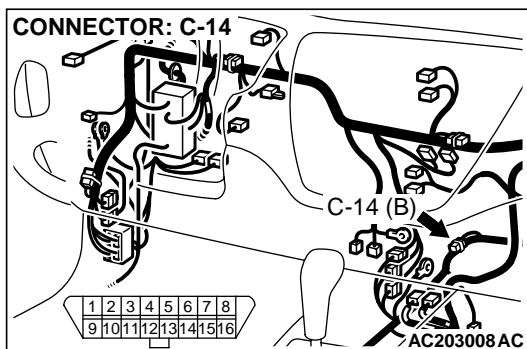

CIRCUIT OPERATION

Power of the auto-cruise control-ECU is transmitted from the ignition switch (IG1) to the auto-cruise control-ECU through multi-purpose fuse 13 in the junction block.

TECHNICAL DESCRIPTION (COMMENT)

The cause is probably a malfunction of the auto-cruise control-ECU power supply circuit or the auto-cruise control-ECU ground circuit.

TROUBLESHOOTING HINTS

- Damaged harness or connector.
- Malfunction of the auto-cruise control-ECU.

DIAGNOSIS**Required Special Tool:**

- MB991223: Harness Set

STEP 1. Measure the signal voltage at auto-cruise control-ECU connector C-107 by backprobing.

- (1) Remove the auto-cruise control-ECU mounting nut. Refer to [P.17-105](#).
- (2) Do not disconnect auto-cruise control-ECU connector C-107.
- (3) Turn the ignition switch to the "ON" position.

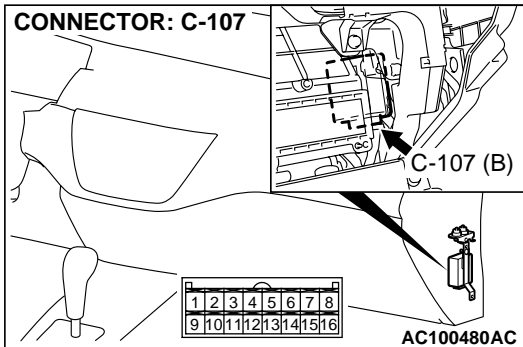

- (4) Measure the voltage between auto-cruise control-ECU connector C-107 terminal 6 and ground by backprobing.
 - The measured voltage should measure battery positive voltage.
- (5) Turn the ignition switch to the "LOCK" (OFF) position.

Q: Is the measured voltage battery positive voltage?

- YES** : Go to Step 5.
NO : Go to Step 2.

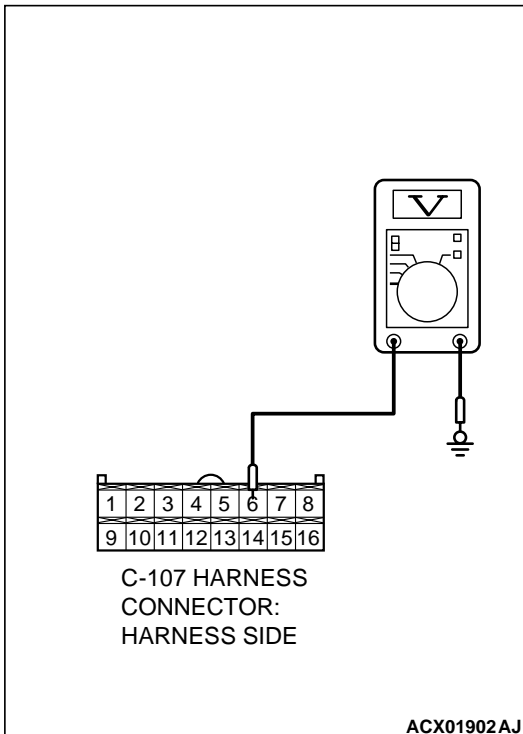

STEP 2. Check auto-cruise control-ECU connector C-107 for loose, corroded or damaged terminals, or terminals pushed back in the connector.

Q: Are the connector and terminals in good condition?

YES : Go to Step 3.

NO : Repair or replace connector. Refer to GROUP 00E, Harness Connector Inspection [P.00E-2](#). Then check that the malfunction is eliminated.

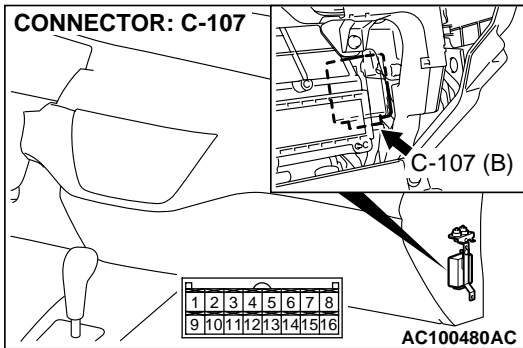

STEP 3. Check junction block connectors C-211, C-214 and intermediate harness connector C-108 for loose, corroded or damaged terminals, or terminals pushed back in the connector.

Q: Are the connectors and terminals in good condition?

YES : Go to Step 4.

NO : Repair or replace connector. Refer to GROUP 00E, Harness Connector Inspection [P.00E-2](#). Then check that the malfunction is eliminated.

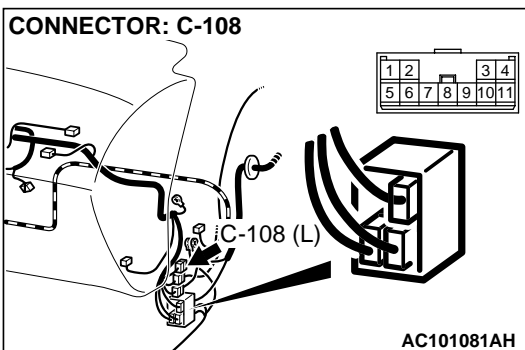
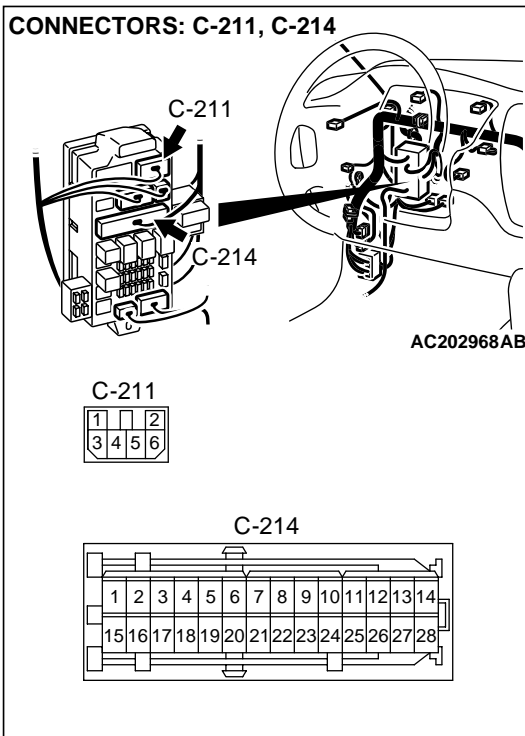

cardiagn.com

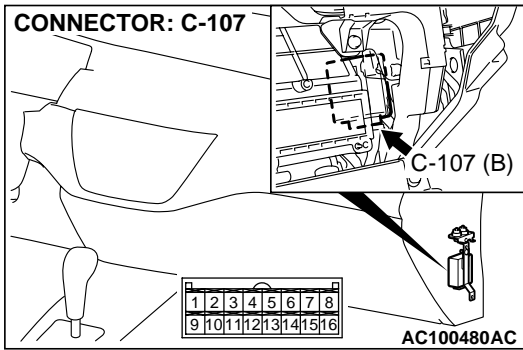

STEP 4. Check the harness wire between ignition switch and auto-cruise control-ECU connector C-107 terminal 6 for damage.

Q: Is the harness wire in good condition?

- YES :** Check that the malfunction is eliminated. If the malfunction is eliminated, replace the auto-cruise control-ECU. (Refer to P.17-105.) Then check that the malfunction is eliminated.
- NO :** Repair the harness wire and then check that the malfunction is eliminated.

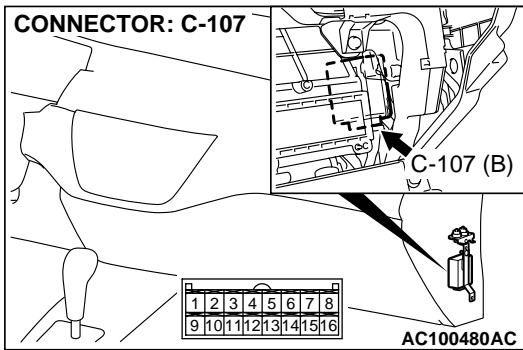

STEP 5. Measure the ground circuit voltage at auto-cruise control-ECU connector C-107 by backprobing.

- (1) Remove the auto-cruise control-ECU mounting nut. Refer to P.17-105.
- (2) Do not disconnect auto-cruise control-ECU connector C-107.
- (3) Turn the ignition switch to the "ON" position.

- (4) Measure the voltage between auto-cruise control-ECU connector C-107 terminal 14 and ground by backprobing.
 - The measured voltage should measure 0.5 volts or less.
- (5) Turn the ignition switch to the "LOCK" (OFF) position.

Q: Is the measured voltage 0.5 volts or less?

- YES :** Go to Step 8.
- NO :** Go to Step 6.

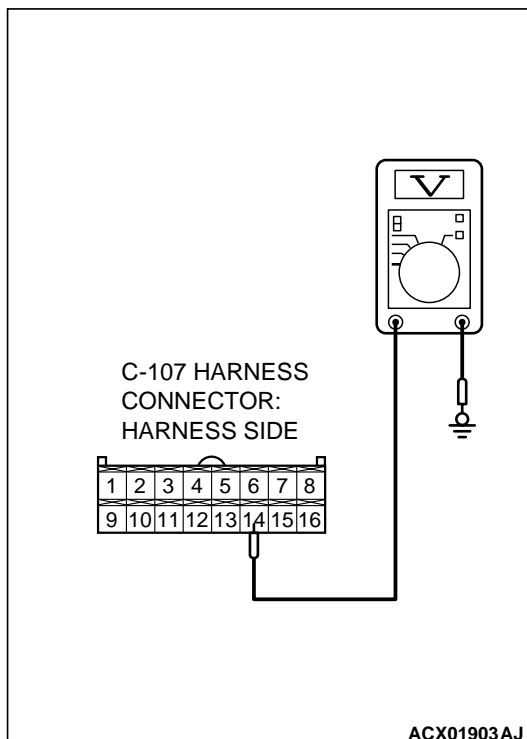

STEP 6. Check auto-cruise control-ECU connector C-107 for loose, corroded or damaged terminals, or terminals pushed back in the connector.

Q: Are the connector and terminals in good condition?

YES : Go to Step 7.

NO : Repair or replace connector. Refer to GROUP 00E, Harness Connector Inspection [P.00E-2](#). Then check that the malfunction is eliminated.

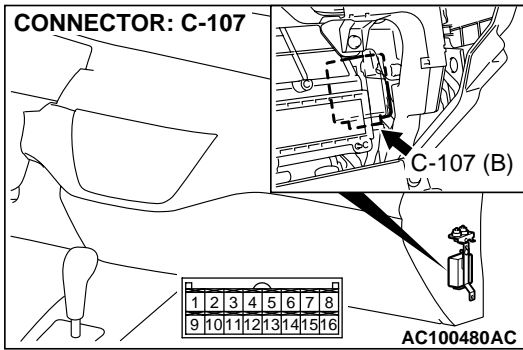

STEP 7. Check the harness wire between auto-cruise control-ECU connector C-107 terminal 14 and ground for damage.

Q: Is the harness wire in good condition?

YES : Check that the malfunction is eliminated. If the malfunction is eliminated, replace the auto-cruise control-ECU. (Refer to [P.17-105](#).) Then check that the malfunction is eliminated.

NO : Repair the harness wire and then check that the malfunction is eliminated.

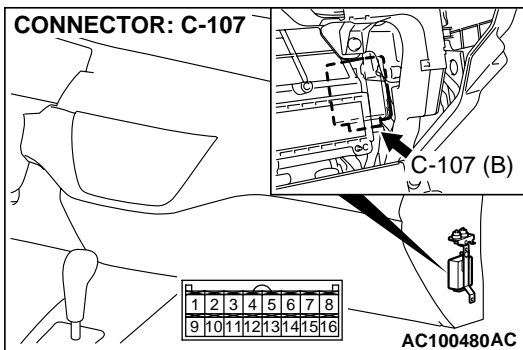

STEP 8. Check data link connector C-14, intermediate harness connector C-108 and auto-cruise control-ECU connector C-107 for loose, corroded or damaged terminals, or terminals pushed back in the connector.

Q: Are the connectors and terminals in good condition?

YES : Go to Step 9.

NO : Repair or replace connector. Refer to GROUP 00E, Harness Connector Inspection [P.00E-2](#). Then check that the malfunction is eliminated.

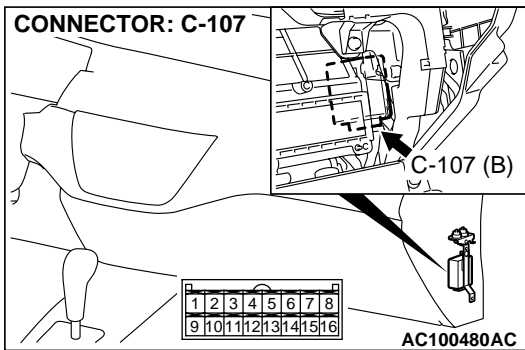
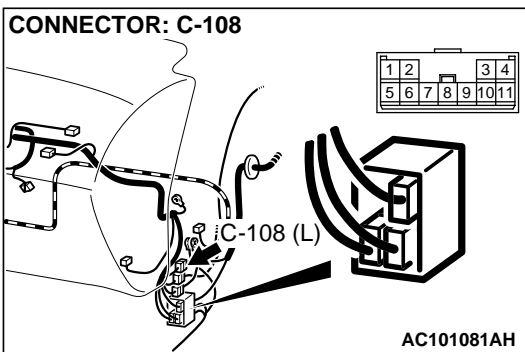
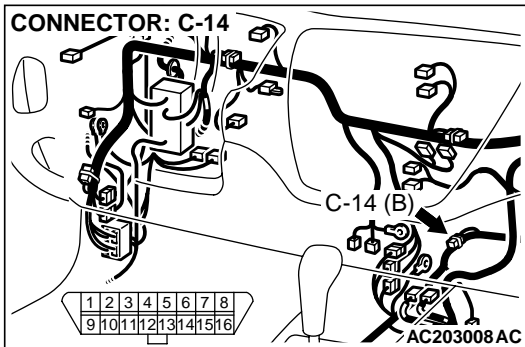

STEP 9. Check the harness wire between auto-cruise control-ECU connector C-107 terminal 17 and data link connector C-14 terminal 13 for damage.

Q: Is the harness wire in good condition?

- YES :** Check that the malfunction is eliminated. If the malfunction is eliminated, replace the auto-cruise control-ECU. (Refer to [P.00E-2.](#)) Then check that the malfunction is eliminated.
- NO :** Repair the harness wire and then check that the malfunction is eliminated.

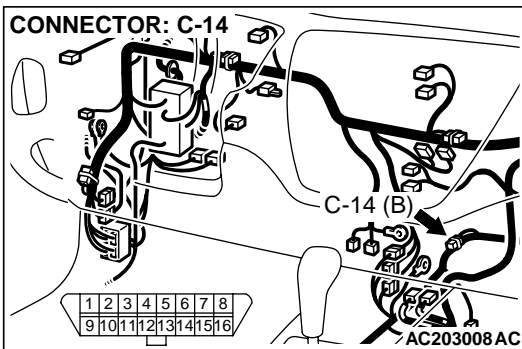
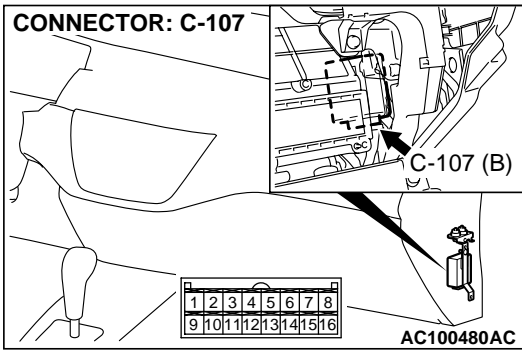

INSPECTION PROCEDURE 2: When the Brake Pedal is Depressed, Auto-cruise Control is not Cancelled.

Stoplight Switch Circuit

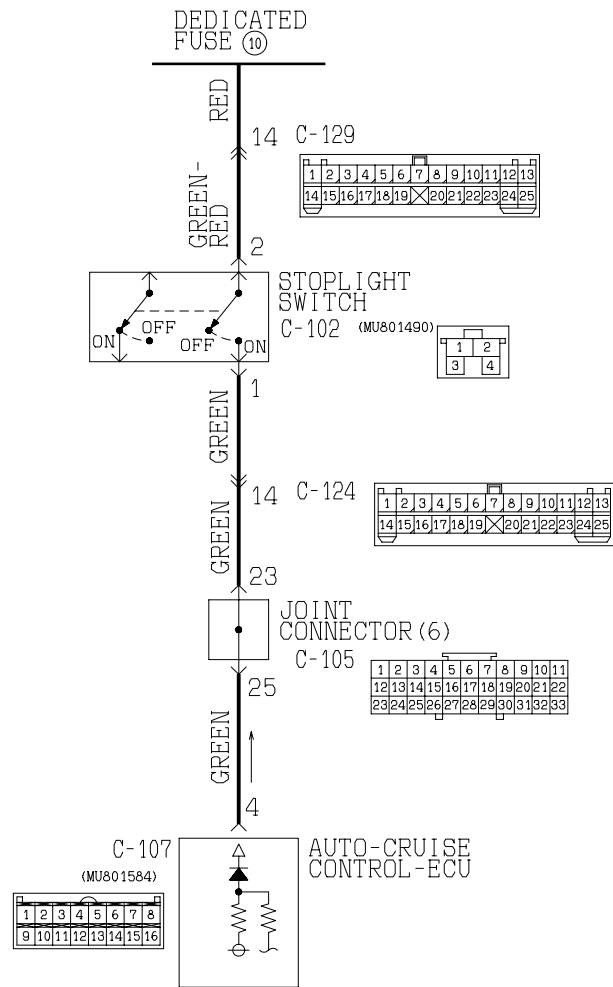

cardiagn.com

AC203124 AB

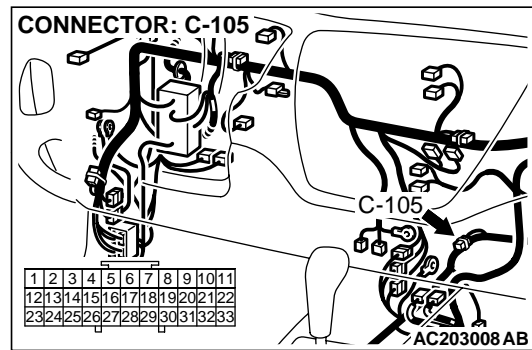
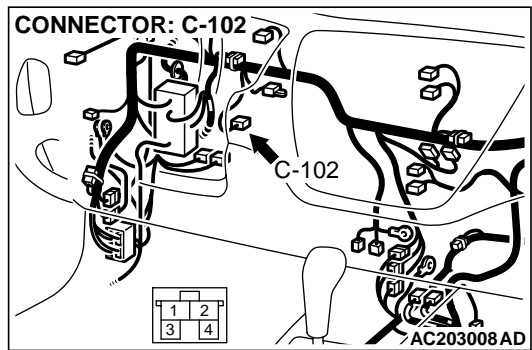

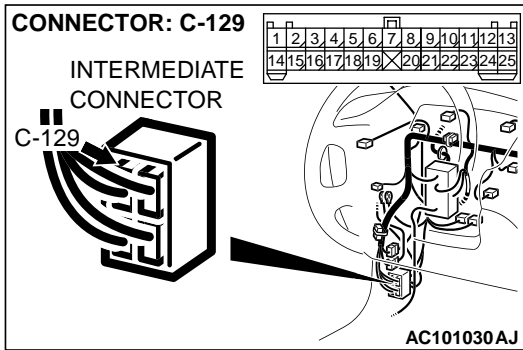
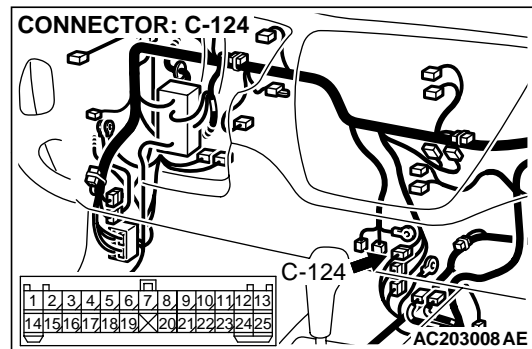
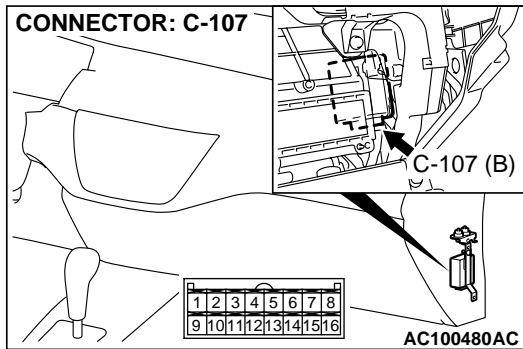

CIRCUIT OPERATION

This is the stoplight switch input signal circuit. The signal is sent to the stoplight switch from multi-purpose fuse 3, and is then sent to the auto-cruise control-ECU.

TECHNICAL DESCRIPTION (COMMENT)

The cause is probably a malfunction of the stoplight switch circuit.

TROUBLESHOOTING HINTS

- Malfunction of the stoplight switch.
- Damaged harness or connector.
- Malfunction of the auto-cruise control-ECU.

DIAGNOSIS

Required Special Tool:

- MB991223: Harness Set

STEP 1. Check if the stoplight illuminates.

Q: Is the stoplight illuminated?

YES : Go to Step 9.

NO : Go to Step 2.

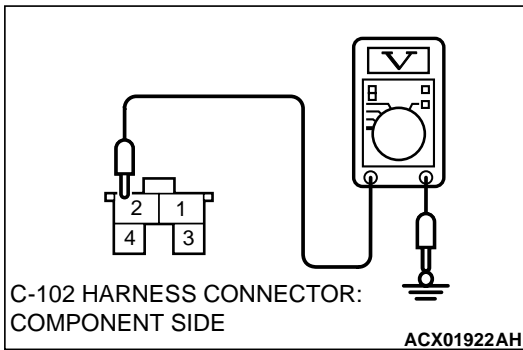
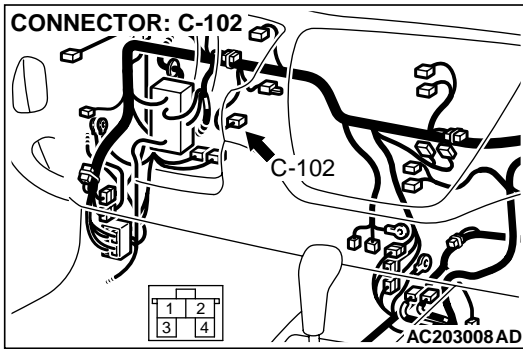

STEP 2. Measure the 12-Volt supply circuit voltage at stoplight switch connector C-102.

(1) Disconnect stoplight switch connector C-102.

(2) Measure the voltage between stoplight switch connector C-102 terminal 2 and ground.

- The measured voltage should measure battery positive voltage.

Q: Is the measured voltage battery positive voltage?

YES : Go to Step 6.

NO : Go to Step 3.

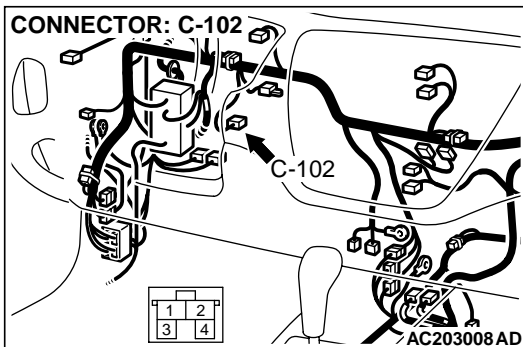

STEP 3. Check stoplight switch connector C-102 for loose, corroded or damaged terminals, or terminals pushed back in the connector.

Q: Are the connector and terminals in good condition?

YES : Go to Step 4.

NO : Repair or replace connector. Refer to GROUP 00E, Harness Connector Inspection [P.00E-2](#). Then check that the malfunction is eliminated.

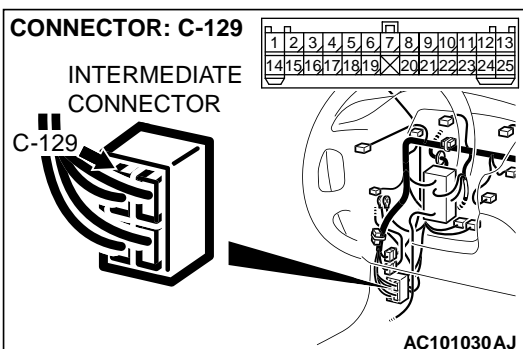

STEP 4. Check intermediate connector C-129 for loose, corroded or damaged terminals, or terminals pushed back in the connector.

Q: Are the connector and terminals in good condition?

YES : Go to Step 5.

NO : Repair or replace connector. Refer to GROUP 00E, Harness Connector Inspection [P.00E-2](#). Then check that the malfunction is eliminated.

STEP 5. Check the harness wire between dedicated fuse No.10 and stoplight switch connector C-102 terminal 2 for damage.

Q: Is the harness wire in good condition?

- YES :** Check that the malfunction is eliminated. If the malfunction is eliminated, replace the auto-cruise control-ECU. (Refer to P.17-105.) Then check that the malfunction is eliminated.
- NO :** Repair the harness wire and then check that the malfunction is eliminated.

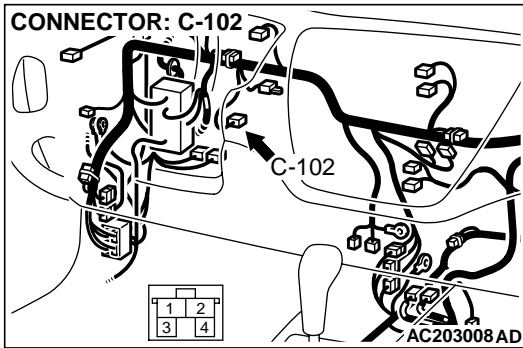

STEP 6. Check the stoplight switch.

(1) Disconnect stoplight switch connector C-102.

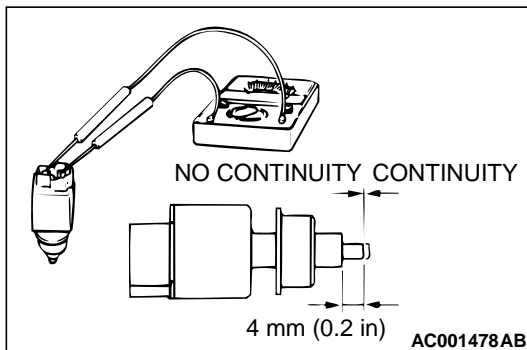
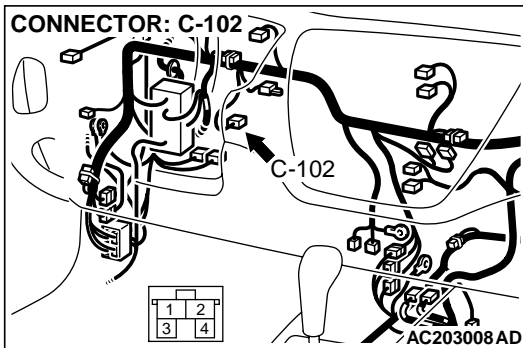

(2) Connect an ohmmeter to the stoplight switch, and check continuity when the plunger of the stoplight switch is pushed in and when it is released.

(3) The stoplight switch is in good condition if the circuit is open when the plunger is pushed in to a depth of within 4 mm (0.2 inch) from the outer case edge surface, and if the resistance value is less than 2 ohm when it is released.

(4) The check for continuity should be made at terminals 1 and 2 of the stoplight switch.

Q: Is the stoplight switch in good condition?

- YES :** Go to Step 7.
- NO :** Replace the stoplight switch. Refer to GROUP 35A, Brake Pedal P.35A-27. Then check that the malfunction is eliminated.

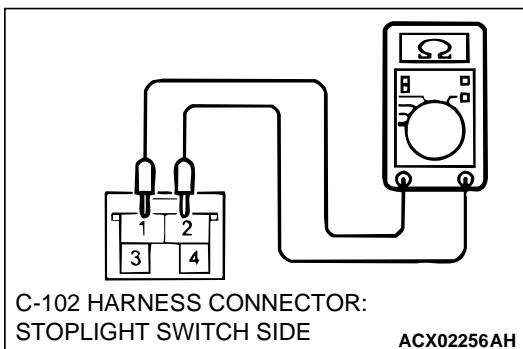

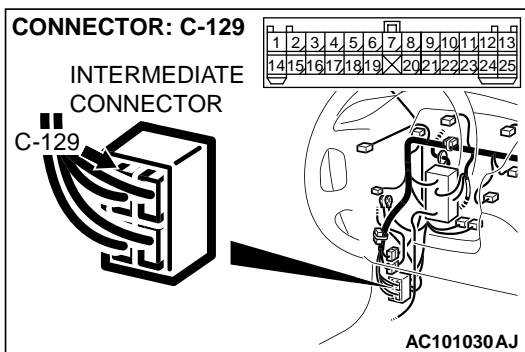
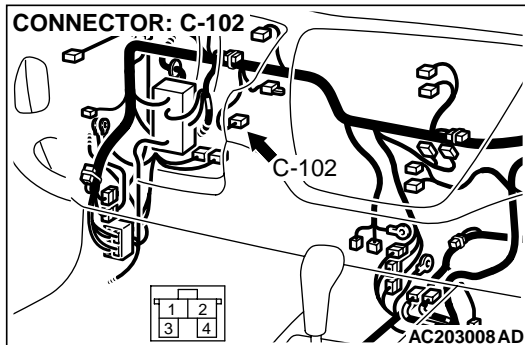

STEP 7. Check stoplight switch connector C-102 and intermediate connector C-129 for loose, corroded or damaged terminals, or terminals pushed back in the connector.

Q: Are the connectors and terminals in good condition?

YES : Go to Step 8.

NO : Repair or replace connector. Refer to GROUP 00E, Harness Connector Inspection P.00E-2. Then check that the malfunction is eliminated.

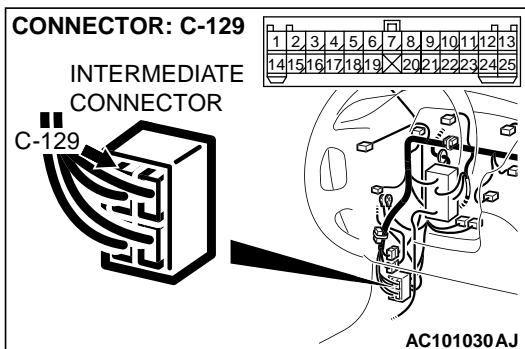
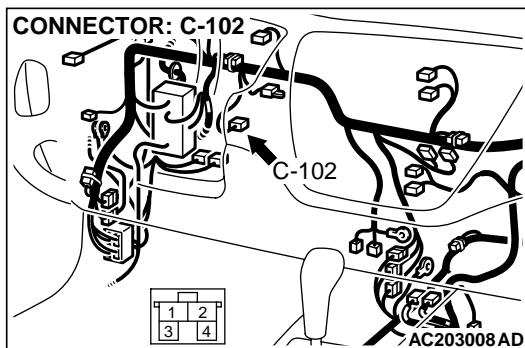

STEP 8. Check the harness wire between stoplight switch connector C-102 terminal 2 and intermediate connector C-129 terminal 14 for damage.

Q: Is the harness wire in good condition?

YES : Check that the malfunction is eliminated. If the malfunction is eliminated, replace the auto-cruise control-ECU. (Refer to P.17-105.) Then check that the malfunction is eliminated.

NO : Repair the harness wire and then check that the malfunction is eliminated.

STEP 9. Measure the signal voltage at auto-cruise control-ECU connector C-107 by backprobing.

- (1) Remove the auto-cruise control-ECU mounting nut. Refer to [P.17-105](#).
- (2) Do not disconnect auto-cruise control-ECU connector C-107.
- (3) Turn the ignition switch to the "ON" position.

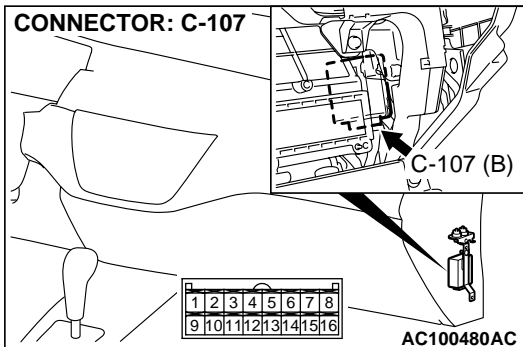

- (4) Measure the voltage between auto-cruise control-ECU connector C-107 terminal 4 and ground by backprobing.
 - The measured voltage should measure battery positive voltage. (When brake pedal is depressed).
 - The measured voltage should measure 0.5 volts or less. (When brake pedal is not depressed).
- (5) Turn the ignition switch to the "LOCK" (OFF) position.

Q: Are all of the measured voltages satisfied?

YES : Check that the malfunction is eliminated. If the malfunction is eliminated, replace the auto-cruise control-ECU. (Refer to [P.17-105](#).) Then check that the malfunction is eliminated.

NO : Go to Step 10.

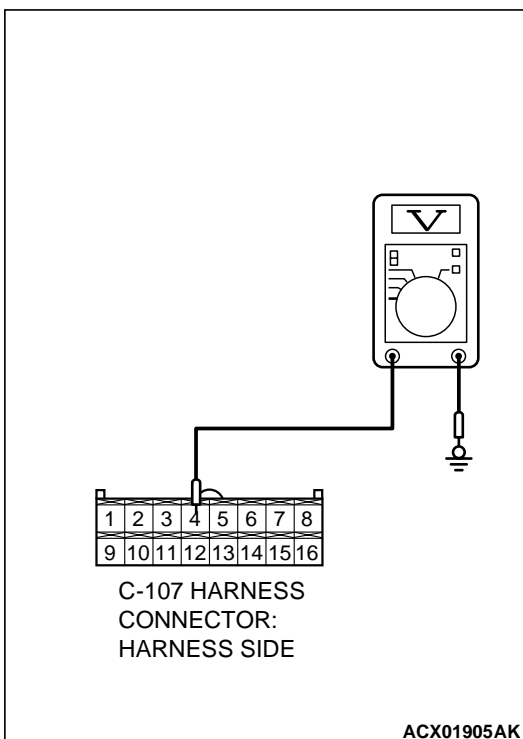

STEP 10. Check auto-cruise control-ECU connector C-107, joint connector C-105 and intermediate connector C-124 for loose, corroded or damaged terminals, or terminals pushed back in the connector.

Q: Are the connectors and terminals in good condition?

YES : Go to Step 11.

NO : Repair or replace connector. Refer to GROUP 00E, Harness Connector Inspection [P.00E-2](#). Then check that the malfunction is eliminated.

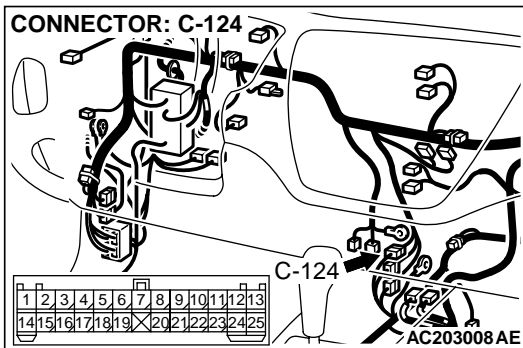
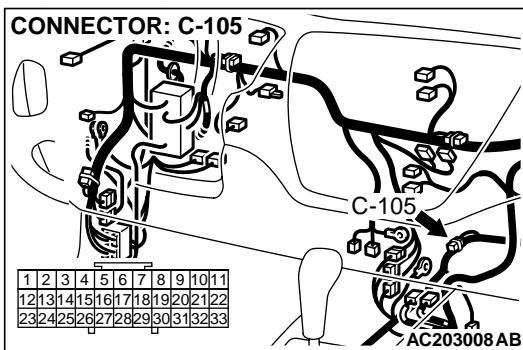
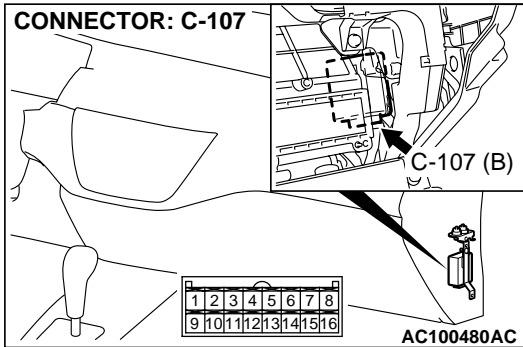

STEP 11. Check the harness wire between stoplight switch connector C-102 terminal 1 and auto-cruise control-ECU connector C-107 terminal 4 for damage.

Q: Is the harness wire in good condition?

- YES :** Check that the malfunction is eliminated. If the malfunction is eliminated, replace the auto-cruise control-ECU. (Refer to P.17-105.) Then check that the malfunction is eliminated.
- NO :** Repair the harness wire and then check that the malfunction is eliminated.

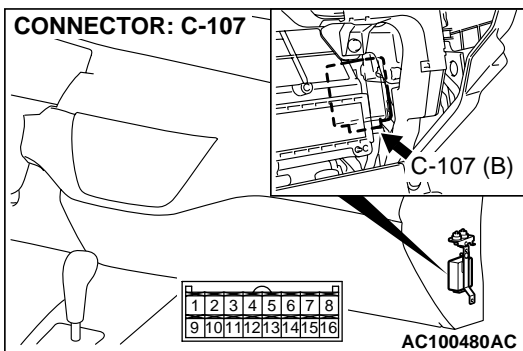
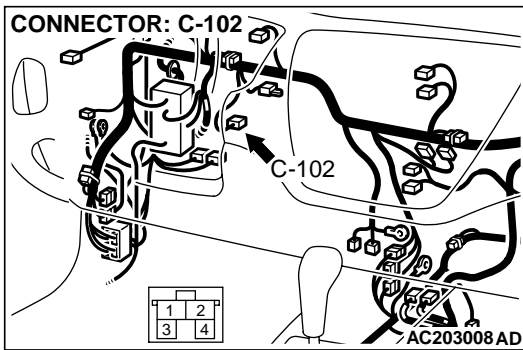

INSPECTION PROCEDURE 3: When the Clutch Pedal is Depressed, Auto-cruise Control is not Cancelled <M/T>

Clutch Pedal Position Switch Circuit

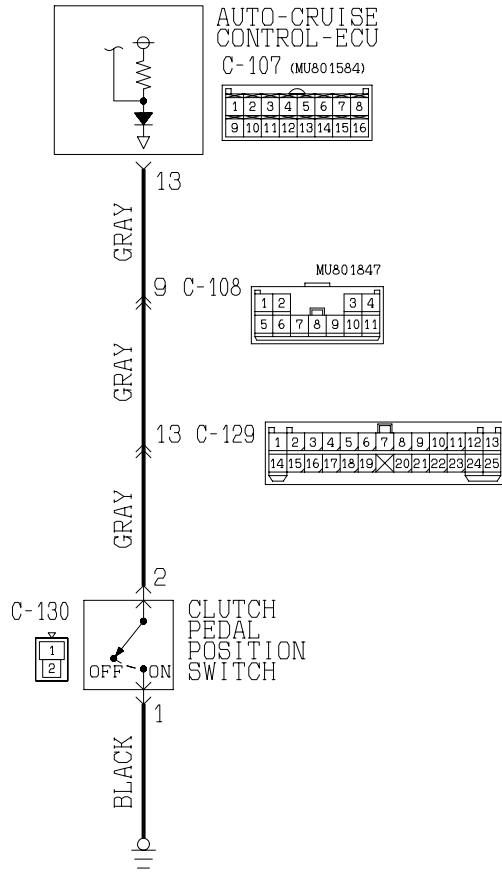

W2J09M11AA

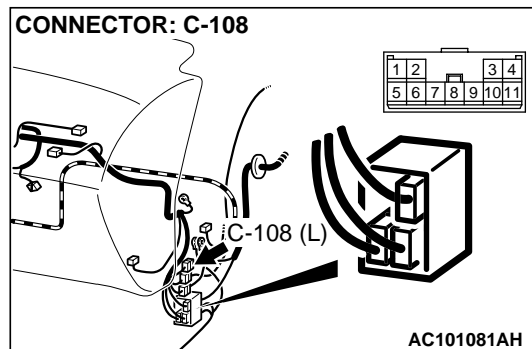
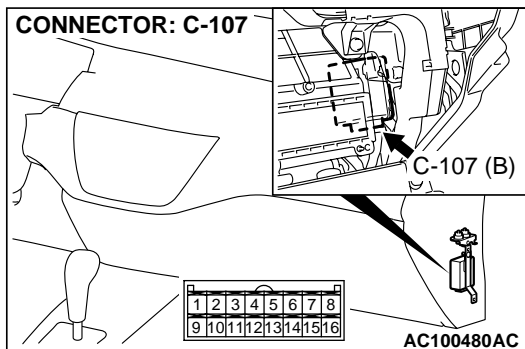

cardiagn.com

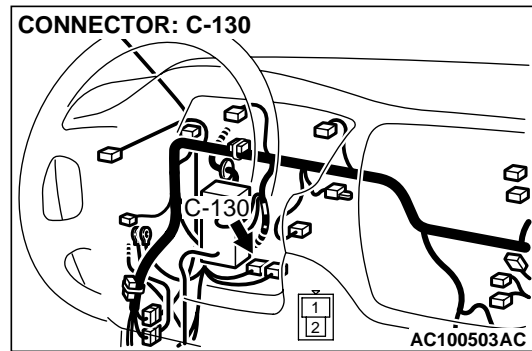
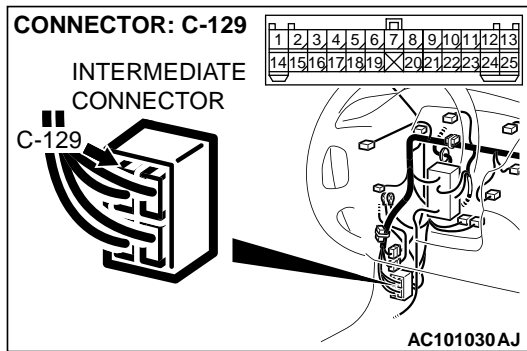

CIRCUIT OPERATION

This circuit indicates the operation status of the clutch pedal position switch. When the clutch pedal position switch is ON (clutch pedal is depressed), the voltage of auto-cruise control-ECU terminal number 13 will indicate 0 volt.

TECHNICAL DESCRIPTION (COMMENT)

The cause is probably a malfunction of the clutch pedal position switch circuit.

TROUBLESHOOTING HINTS

- Malfunction of the clutch pedal position switch.
- Damaged harness or connector.
- Malfunction of the auto-cruise control-ECU.

DIAGNOSIS

STEP 1. Check the clutch pedal position switch.

(1) Disconnect clutch pedal position switch connector C-130.

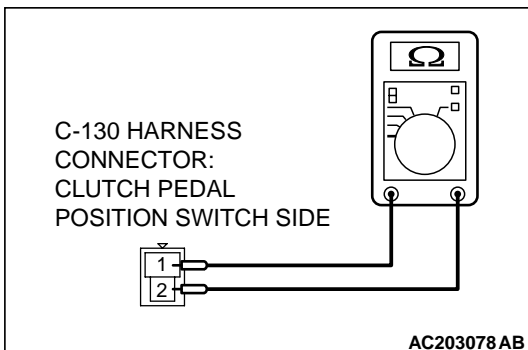
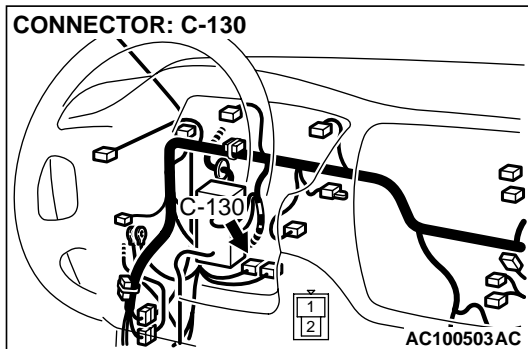

(2) Measure the continuity between the terminals.

MEASUREMENT CONDITIONS	TERMINAL CONNECTOR OF TESTER	SPECIFIED CONDITION
When clutch pedal is depressed.	1 – 2	Less than 2 ohms
When clutch pedal is not depressed.	1 – 2	Open circuit

Q: Is the clutch pedal position switch in good condition?

YES : Go to Step 2.

NO : Replace the clutch pedal position switch. Refer to GROUP 21A, Clutch [P.21A-9](#). Then check that the malfunction is eliminated.

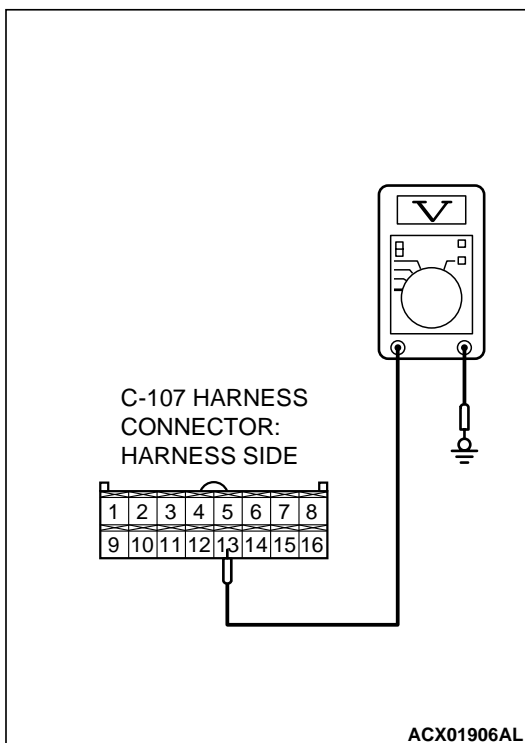
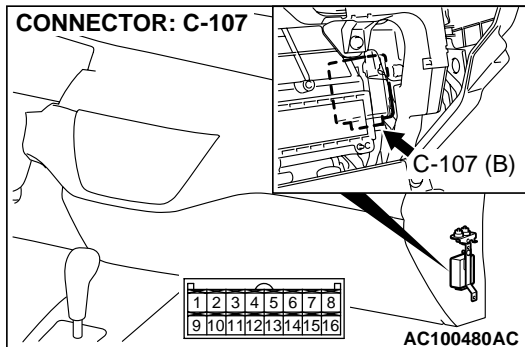

STEP 2. Measure the signal voltage at auto-cruise control-ECU connector C-107 by backprobing.

- (1) Remove the auto-cruise control-ECU mounting nut. Refer to [P.17-105](#).
- (2) Do not disconnect auto-cruise control switch connector C-107.
- (3) Turn the ignition switch to the "ON" position.
- (4) Measure the voltage between auto-cruise control-ECU connector C-107 terminal 13 and ground by backprobing.
 - voltage should measure 0.5 volts or less. (When clutch pedal is depressed.)
 - voltage should measure battery positive voltage. (When clutch pedal is not depressed.)
- (5) Turn the ignition switch to the "LOCK" (OFF) position.

Q: Are all of the measured voltages satisfied?

YES : Check that the malfunction is eliminated. If the malfunction is eliminated, replace the auto-cruise control-ECU. (Refer to [P.17-105](#).) Then check that the malfunction is eliminated.

NO : Go to Step 3.

STEP 3. Check clutch pedal position switch connector C-130, auto-cruise control-ECU connector C-107, intermediate connectors C-108 and C-129 for loose, corroded or damaged terminals, or terminals pushed back in the connector.

Q: Are the connectors and terminals in good condition?

YES : Go to Step 4.

NO : Repair or replace connector. Refer to GROUP 00E, Harness Connector Inspection P.00E-2. Then check that the malfunction is eliminated.

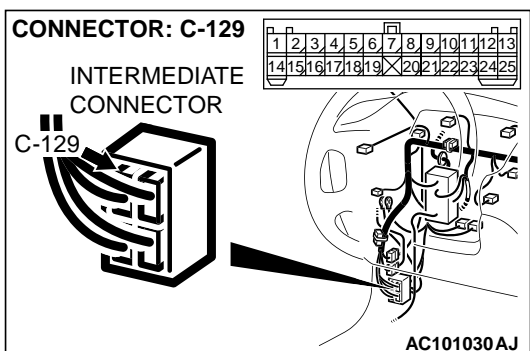
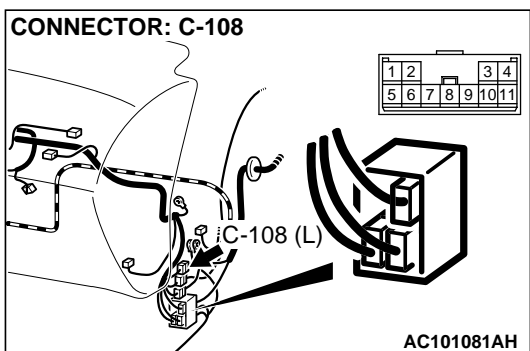
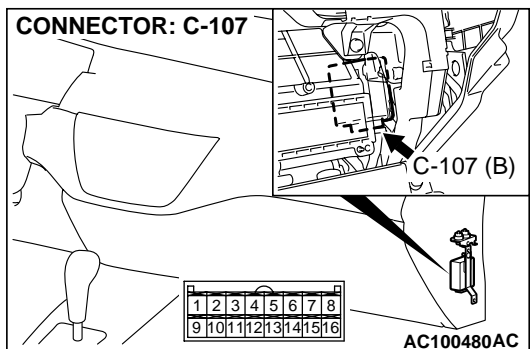
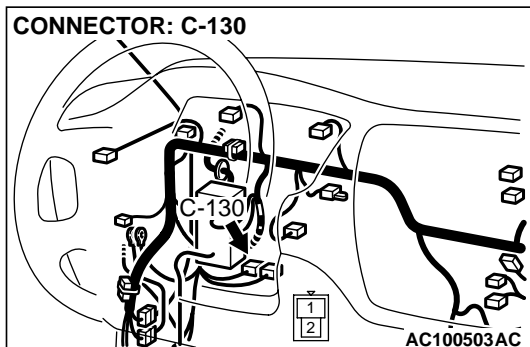

cardiagn.com

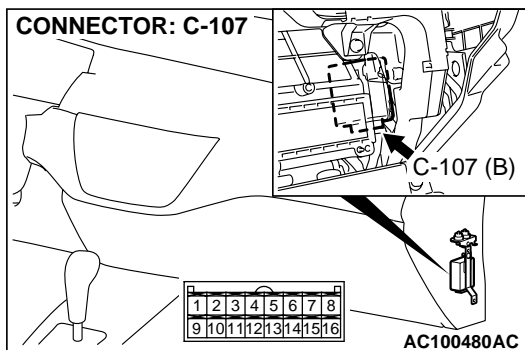
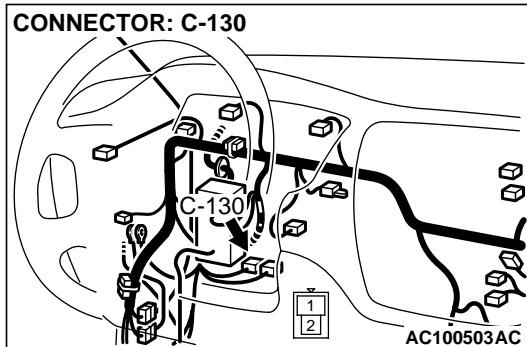

STEP 4. Check the harness wire between clutch pedal position switch connector C-130 terminal 2 and auto-cruise control-ECU connector C-107 terminal 13 for damage.

Q: Is the harness wire in good condition?

YES : Go to Step 5.

NO : Repair the harness wire and then check that the malfunction is eliminated.

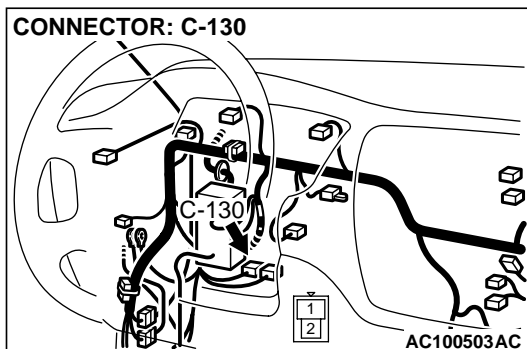

STEP 5. Check the harness wire between clutch pedal position switch connector C-130 terminal 1 and ground wire for damage.

Q: Is the harness wire in good condition?

YES : Check that the malfunction is eliminated. If the malfunction is eliminated, replace the auto-cruise control-ECU. (Refer to [P.17-105.](#)) Then check that the malfunction is eliminated.

NO : Repair the harness wire and then check that the malfunction is eliminated.

INSPECTION PROCEDURE 4: When the Selector Lever is Moved to "N" Range, Auto-cruise Control is not Cancelled <A/T>.

Park/neutral Position Switch Circuit

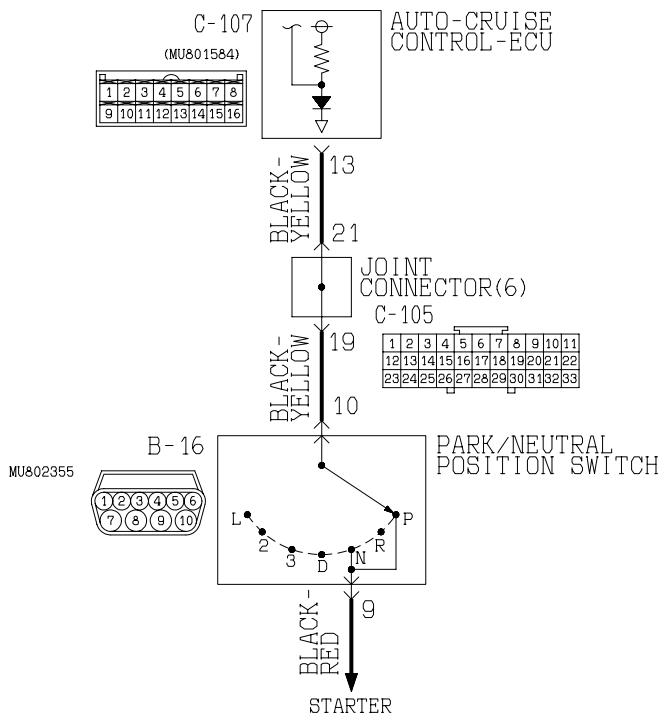

W2J09M01AA

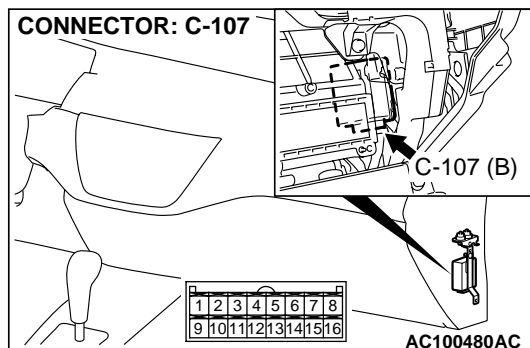
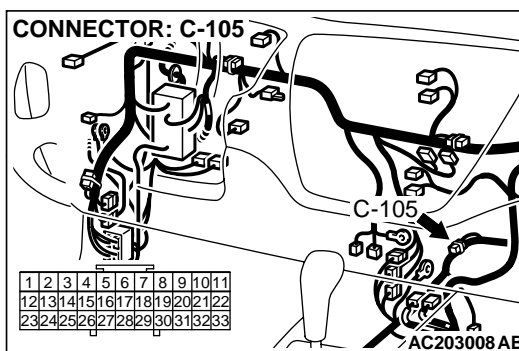
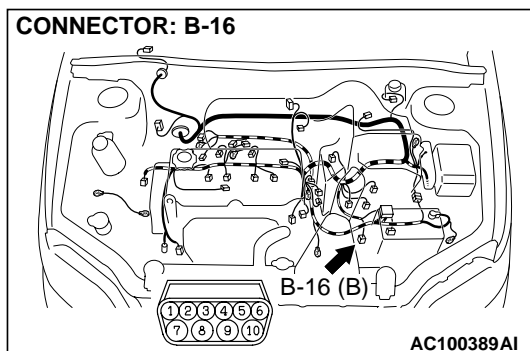

CIRCUIT OPERATION

This circuit transmits the "N" or "P" position signal of the park/neutral position switch to the auto-cruise control-ECU. When the park/neutral position switch is at the "N" or "P" position, auto-cruise control-ECU terminal number 13 will receive 0 volt.

TECHNICAL DESCRIPTION (COMMENT)

The cause is probably an open-circuit in the output signal circuit in "N" range.

TROUBLESHOOTING HINTS

- Malfunction of the park/neutral position switch.
- Damaged harness or connector.
- Malfunction of the auto-cruise control-ECU.

DIAGNOSIS**Required Special Tool:**

- MB991223: Harness Set

STEP 1. Check the output circuit voltage at park/neutral position switch connector B-16 by backprobing.

- (1) Do not disconnect park/neutral position switch connector B-16.
- (2) Turn the ignition switch to the "ON" position.

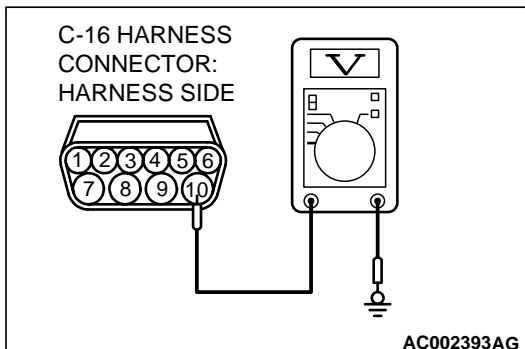
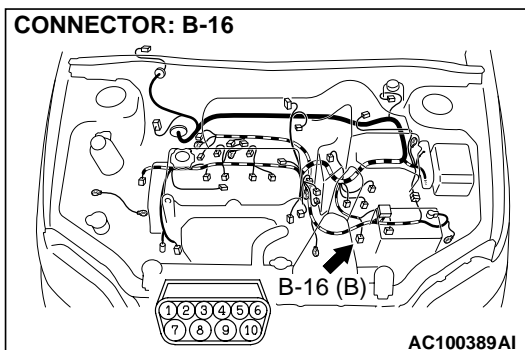

- (3) Measure the voltage between park/neutral position switch connector B-16 terminal 10 and ground by backprobing.
 - The measured voltage should measure battery positive voltage. (When select lever is in a position other than "N" range.)
 - The measured voltage should measure 0.5 volts or less. (When select lever is in "N" range.)
- (4) Turn the ignition switch to the "LOCK" (OFF) position.

Q: Are all of the measured voltages satisfied?

YES : Check that the malfunction is eliminated. If the malfunction is eliminated, replace the auto-cruise control-ECU. (Refer to [P.17-105.](#)) Then check that the malfunction is eliminated.

NO : Go to Step 2.

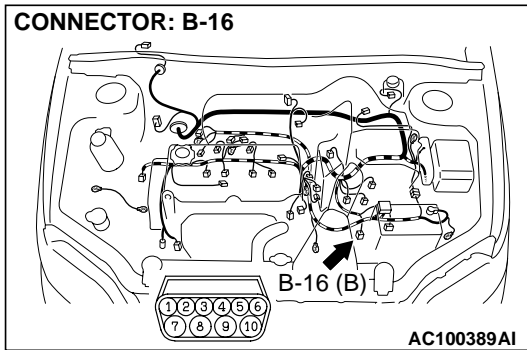

STEP 2. Check park/neutral position switch connector B-16 for loose, corroded or damaged terminals, or terminals pushed back in the connector.

Q: Are the connector and terminals in good condition?

YES : Go to Step 3.

NO : Repair or replace connector. Refer to GROUP 00E, Harness Connector Inspection [P.00E-2](#). Then check that the malfunction is eliminated.

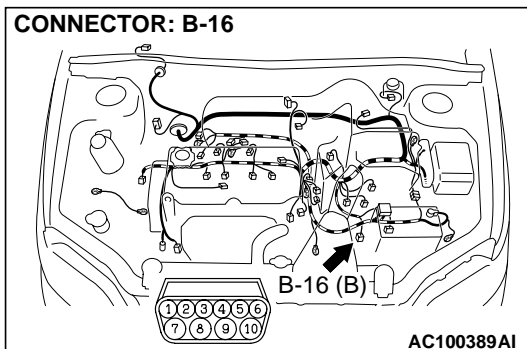

STEP 3. Check the circuit at the park/neutral position switch.

(1) Disconnect the park/neutral position switch connector B-16.

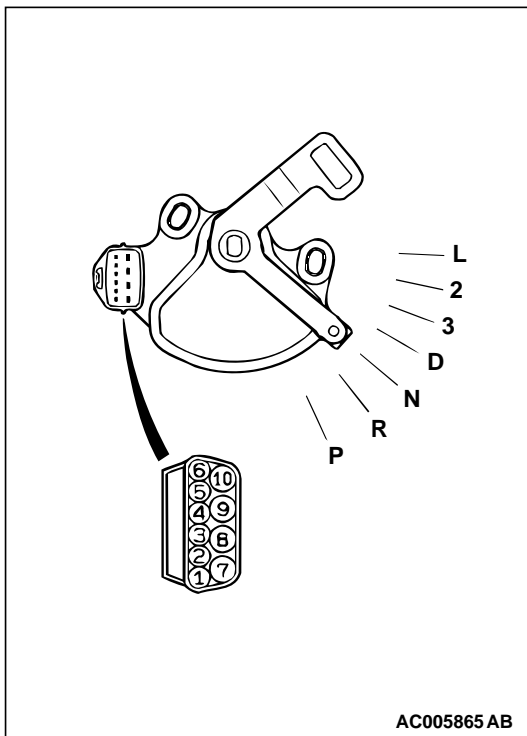

(2) Measure the continuity park/neutral position switch connector terminals.

ITEMS	TERMINAL CONNECTOR OF TESTER	SPECIFIED CONDITION
P	3 – 8, 9 – 10	Less than 2 ohms.
N	4 – 8, 9 – 10	

Q: Is the continuity meet the table above?

YES : Go to Step 4.

NO : Replace the park/neutral position switch. Refer to GROUP 23A, Transmission [P.23B-8](#). Then check that the malfunction is eliminated.

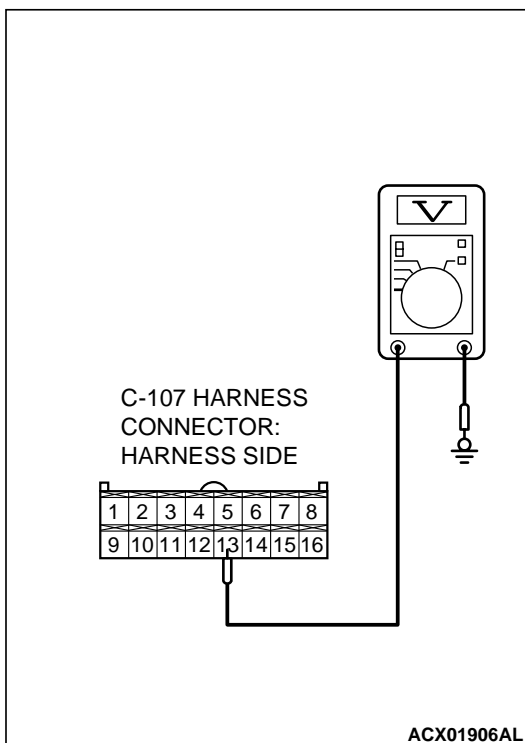
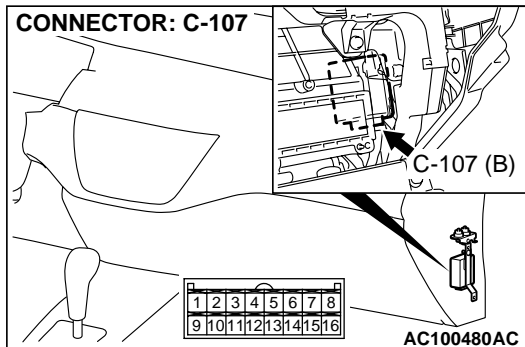
**STEP 4. Measure the signal voltage at auto-cruise control-ECU connector C-107 by backprobing.**

- (1) Remove the auto-cruise control-ECU mounting nut. Refer to [P.17-105](#).
- (2) Do not disconnect auto-cruise control-ECU connector C-107.
- (3) Turn the ignition switch to the "ON" position.

- (4) Measure the voltage between auto-cruise control-ECU connector C-107 terminal 13 and ground by backprobing.
 - The measured voltage should measure battery positive voltage. (When select lever is in a position other than "N" range).
 - The measured voltage should measure 0.5 volts or less. (When select lever is in "N" range).
- (5) Turn the ignition switch to the "LOCK" (OFF) position.

Q: Are all of the measured voltages satisfied?

YES : Check that the malfunction is eliminated. If the malfunction is eliminated, replace the auto-cruise control-ECU. (Refer to [P.17-105](#).) Then check that the malfunction is eliminated.

NO : Go to Step 5.

STEP 5. Check auto-cruise control-ECU connector C-107 for loose, corroded or damaged terminals, or terminals pushed back in the connector.**Q: Are the connector and terminals in good condition?**

YES : Go to Step 6.

NO : Repair or replace connector. Refer to GROUP 00E, Harness Connector Inspection [P.00E-2](#). Then check that the malfunction is eliminated.

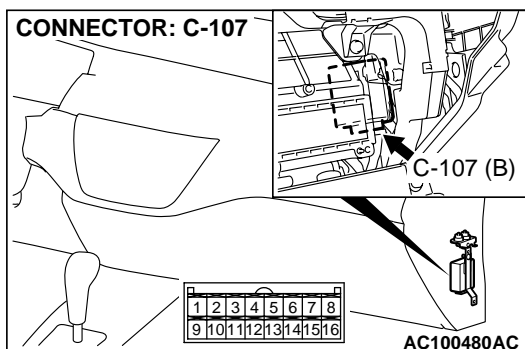

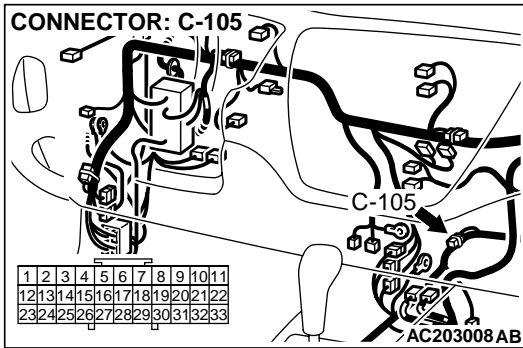

STEP 6. Check intermediate connector C-105 for loose, corroded or damaged terminals, or terminals pushed back in the connector.

Q: Are the connector and terminals in good condition?

YES : Go to Step 7.

NO : Repair or replace connector. Refer to GROUP 00E, Harness Connector Inspection [P.00E-2](#). Then check that the malfunction is eliminated.

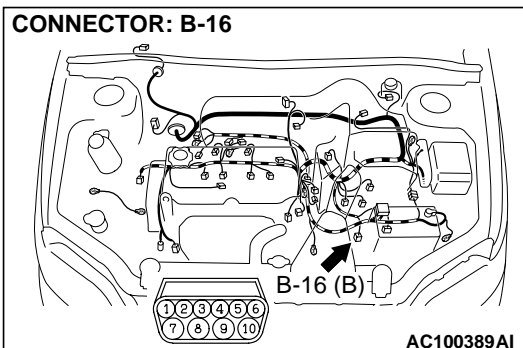

STEP 7. Check the harness wire between park/neutral position switch connector B-16 terminal 10 and auto-cruise control-ECU connector C-107 terminal 13 for damage.

Q: Is the harness wire in good condition?

YES : Check that the malfunction is eliminated. If the malfunction is eliminated, replace the auto-cruise control-ECU. (Refer to [P.17-105](#).) Then check that the malfunction is eliminated.

NO : Repair the harness wire and then check that the malfunction is eliminated.

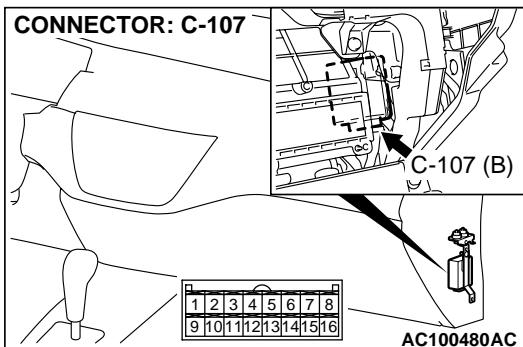

INSPECTION PROCEDURE 5: When the Auto-cruise Control "CANCEL" Switch is Set to ON, Auto-cruise Control is not Cancelled.

TECHNICAL DESCRIPTION (COMMENT)

The cause is probably an open-circuit in the output in the circuit inside the "CANCEL" switch.

TROUBLESHOOTING HINTS

- Malfunction of the auto-cruise control switch.

DIAGNOSIS

Replace the auto-cruise control switch. (Refer to [P.17-105.](#)) Then check the malfunction is eliminated.

INSPECTION PROCEDURE 6: Auto-cruise Control cannot be Set.

TECHNICAL DESCRIPTION (COMMENT)

The fail-safe function is probably cancelling auto-cruise control. In this case, scan tool MB991502 can be used to Retest the system in each system by checking the diagnostic trouble codes. The scan tool can also be used to check if the circuits of each input switch are normal or not by checking the input switch codes.

TROUBLESHOOTING HINTS

- Malfunction of the auto-cruise control switch.
- Malfunction of the auto-cruise control-ECU.
- Malfunction of the auto-cruise control switch.
- Malfunction of the auto-cruise control-ECU.

DIAGNOSIS

Required Special Tools:

- MB991502: Scan Tool (MUT-II)
- MB991223: Harness Set

STEP 1. Can the auto-cruise control-ECU communicate with scan tool MB991502?

⚠ CAUTION

To prevent damage to scan tool MB991502, always turn the ignition switch to the "LOCK" (OFF) position before connecting or disconnecting scan tool MB991502.

- (1) Using scan tool MB991502.
- (2) Connect scan tool MB991502 to the data link connector.
- (3) Turn the ignition switch to the "ON" position.

Q: Can the auto-cruise control-ECU communicate with the scan tool?

YES : Go to Step 2.

NO : Inspect each trouble symptom. (Refer to Inspection Procedure number 1 [P.17-58.](#))

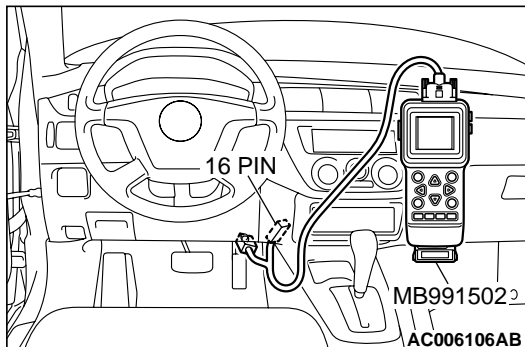

STEP 2. Is any diagnostic trouble code output?

Q: Is any diagnostic trouble code output?

YES : Diagnostic trouble code number 11, 12, 14, 15, 16 or 17 is output, refer to the following. (Code number 11 [P.17-11.](#)) (Code number 12 <M/T>[P.17-17.](#)) (Code number 12 <A/T>[P.17-20.](#)) (Code number 14 [P.17-22.](#)) (Code number 15 [P.17-36.](#)) (Code number 16 [P.17-44.](#)) (Code number 17 <M/T>[P.17-44.](#)) (Code number 17 <A/T>[P.17-51.](#)) Then check that the malfunction is eliminated.

NO : Go to Step 3.

STEP 3.Using scan tool MB991502, check data list.

⚠ CAUTION

To prevent damage to scan tool MB991502, always turn the ignition switch to the "LOCK" (OFF) position before connecting or disconnecting scan tool MB991502.

- (1) Using scan tool MB991502.
- (2) Connect scan tool MB991502 to the data link connector.
- (3) Check the following items in the data list.

Refer to [P.17-98](#), Data List Reference Table.

- Item 04: Auto-cruise control "CANCEL" switch.
- Item 05: Stoplight switch.
- Item 14: Clutch pedal position switch <M/T>.
- Item 14: Park/neutral position switch <A/T>.

- (4) Turn the ignition switch to the "ON" position.

Q: Is the check above meet the specifications?

YES : Check that the malfunction is eliminated. If the malfunction is eliminated, replace the auto-cruise control-ECU. (Refer to [P.17-105.](#)) Then that the malfunction is eliminated.

NO : Follow the diagnostic trouble code procedures and the symptom procedures below.

- Item 04: Refer to Diagnostic Trouble Code Procedures number 15 [P.17-36.](#)
- Item 05: Refer to Symptom Procedures number 2 [P.17-66.](#)
- Item 14: Refer to Symptom Procedures number 3 <M/T>[P.17-74.](#)
- Item 14: Refer to Symptom Procedures number 4 <A/T>[P.17-79.](#)

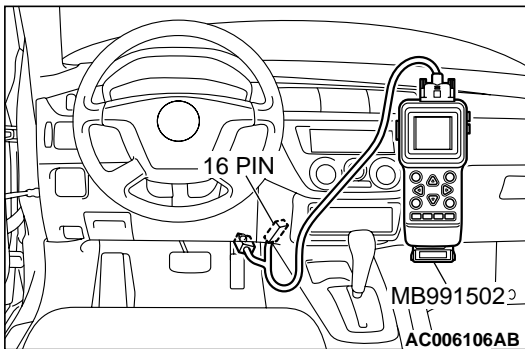

INSPECTION PROCEDURE 7: Hunting (Repeated Acceleration and Deceleration) Occurs at the Set Vehicle Speed <M/T>.**TECHNICAL DESCRIPTION (COMMENT)**

The cause is probably the malfunction of the vehicle speed sensor or incorrect vacuum in the auto-cruise control vacuum pump or actuator.

TROUBLESHOOTING HINTS

- Malfunction of the vehicle speed sensor.
- Malfunction of the auto-cruise control vacuum pump.
- Malfunction of the actuator.
- Malfunction of the auto-cruise control-ECU.

DIAGNOSIS**Required Special Tool:**

- MB991223: Harness Set

STEP 1. Check the vehicle speed sensor.

- (1) Remove the vehicle speed sensor and connect a 3 – 10-k Ω resistor as shown in the illustration.
- (2) Turn the shaft of the vehicle speed sensor and check that there is voltage between terminals 2 – 3. (one turn = four pulses)

Q: Is the voltage within specifications?

YES : Go to Step 2.

NO : Replace the vehicle speed sensor. Refer to GROUP 54A, Combination Meter Assembly and Vehicle Speed Sensor P.54A-42. Then check that the malfunction is eliminated.

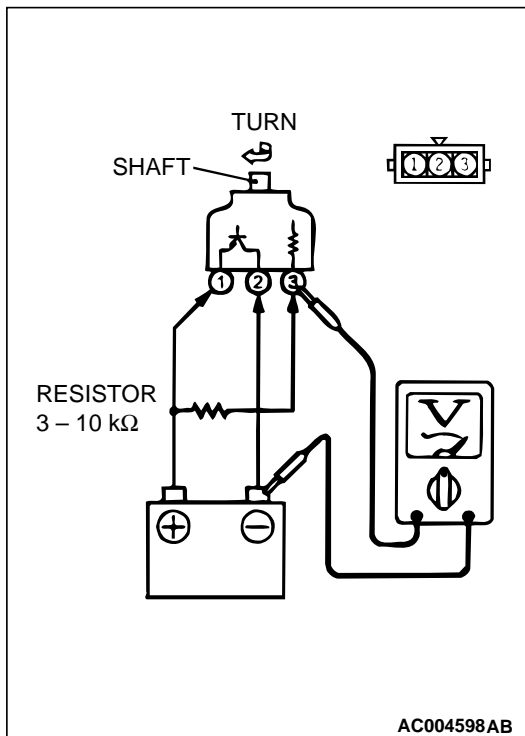

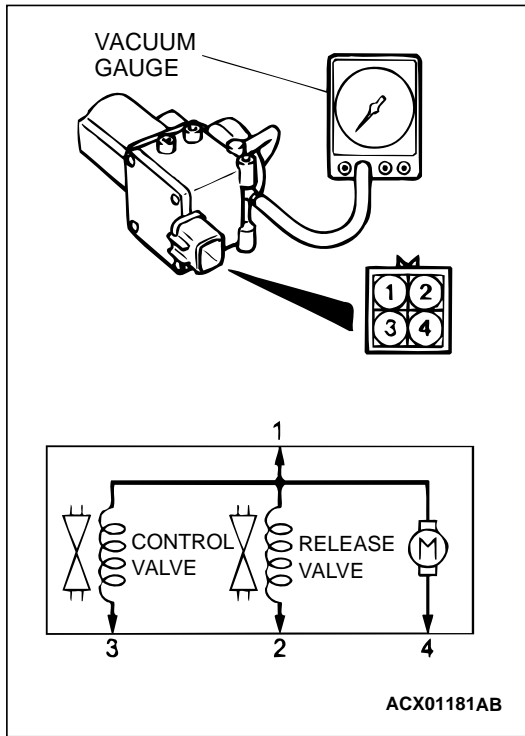

STEP2. Check the auto-cruise vacuum pump.

- (1) Disconnect the vacuum hose from the auto-cruise vacuum pump and connect a vacuum gauge to the vacuum pump.
- (2) Disconnect the vacuum pump connector.
- (3) Check the auto-cruise vacuum pump and valves according to the following procedure:
 - a. Connect the positive battery terminal to auto-cruise vacuum pump connector terminal 1, and the negative battery terminal to terminals 2, 3, and 4. Then the vacuum gauge should read 27 kPa (8.0 in Hg) or more.
 - b. The vacuum should be maintained when terminal 4 is disconnected from the negative battery terminal while terminals 1, 2, and 3 remain connected. Then the vacuum gauge should read 0 kPa (0 in Hg) when terminal 2 is disconnected from the negative battery terminal while terminals 1, and 3 remain connected.
 - c. The vacuum should be maintained when terminal 4 is disconnected from the negative battery terminal while terminals 1, 2, and 3 remain connected. Then the vacuum gauge should read 0 kPa (0 in Hg) when terminal 3 is disconnected from the negative battery terminal while terminals 1, and 2 remain connected.

Q: Are all of the above values satisfied?

YES : Go to Step 3.

NO : Replace the auto-cruise vacuum pump. (Refer to [P.17-105.](#)) Then that the malfunction is eliminated.

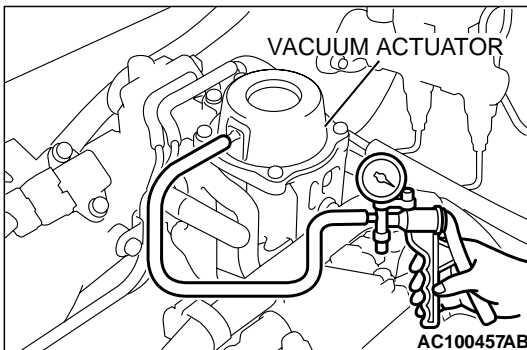

STEP 3. Check the vacuum actuator.

- (1) Disconnect the vacuum hose from the vacuum actuator, and then connect a hand vacuum pump to the vacuum actuator.
- (2) Apply a vacuum and check that the throttle lever moves and the vacuum is maintained.

Q: Is the vacuum actuator damaged?

YES : Replace the vacuum actuator. Refer to GROUP 13A, Throttle Body Assembly [P.13Aa-30.](#) Then check that the malfunction is eliminated.

NO : Check that the malfunction is eliminated. If the malfunction is eliminated, replace the auto-cruise control-ECU. (Refer to [P.13Aa-30.](#)) Then check that the malfunction is eliminated.

INSPECTION PROCEDURE 7: Hunting (Repeated Acceleration and Deceleration) Occurs at the Set Vehicle Speed <A/T>.**TECHNICAL DESCRIPTION (COMMENT)**

The cause is probably the malfunction of the output shaft speed sensor or PCM or incorrect vacuum in the auto-cruise control vacuum pump or actuator.

TROUBLESHOOTING HINTS

- Malfunction of the output shaft speed sensor.
- Malfunction of the PCM.
- Malfunction of the auto-cruise control vacuum pump.
- Malfunction of the actuator.
- Malfunction of the auto-cruise control-ECU.

DIAGNOSIS**Required Special Tool:**

- MB991502: Scan Tool (MUT-II)
- MB991223: Harness Set

STEP 1. Check the vehicle speed signal.**CAUTION**

To prevent damage to scan tool MB991502, always turn the ignition switch to the "LOCK" (OFF) position before connecting or disconnecting scan tool MB991502.

- (1) Using scan tool MB991502.
- (2) Connect scan tool MB991502 to the data link connector.
- (3) Turn the ignition switch to the "ON" position.
- (4) Read the MFI-DTC.
- (5) Turn the ignition switch to the "LOCK" (OFF) position.

Q: Is the MFI-DTC P0720 is output?

YES : Refer to GROUP 13A, Diagnosis – Diagnostic Trouble Code Chart [P.13Ab-19](#).

NO : Go to Step 2.

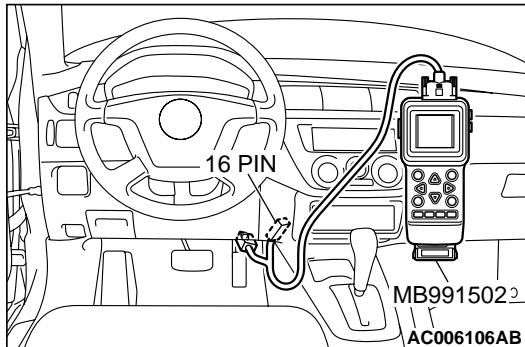

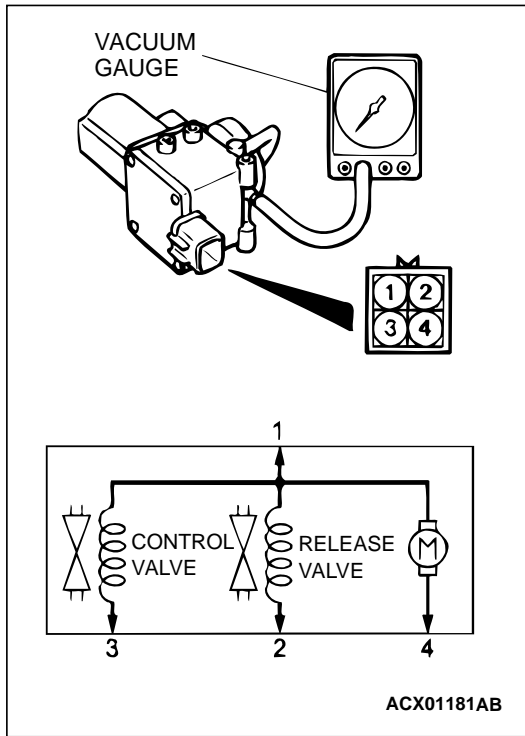

STEP2. Check the auto-cruise vacuum pump.

- (1) Disconnect the vacuum hose from the auto-cruise vacuum pump and connect a vacuum gauge to the vacuum pump.
- (2) Disconnect the vacuum pump connector.
- (3) Check the auto-cruise vacuum pump and valves according to the following procedure:
 - a. Connect the positive battery terminal to auto-cruise vacuum pump connector terminal 1, and the negative battery terminal to terminals 2, 3, and 4. Then the vacuum gauge should read 27 kPa (8.0 in Hg) or more.
 - b. The vacuum should be maintained when terminal 4 is disconnected from the negative battery terminal while terminals 1, 2, and 3 remain connected. Then the vacuum gauge should read 0 kPa (0 in Hg) when terminal 2 is disconnected from the negative battery terminal while terminals 1, and 3 remain connected.
 - c. The vacuum should be maintained when terminal 4 is disconnected from the negative battery terminal while terminals 1, 2, and 3 remain connected. Then the vacuum gauge should read 0 kPa (0 in Hg) when terminal 3 is disconnected from the negative battery terminal while terminals 1, and 2 remain connected.

Q: Are all of the above values satisfied?

YES : Go to Step 3.

NO : Replace the auto-cruise vacuum pump. (Refer to [P.17-105.](#)) Then that the malfunction is eliminated.

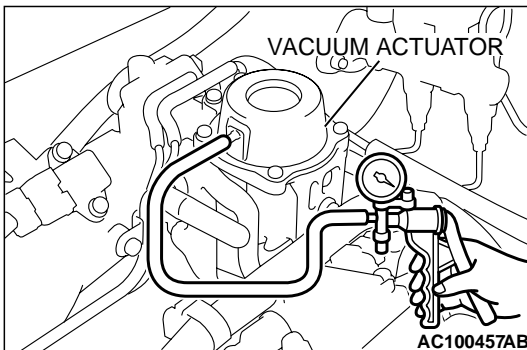

STEP 3. Check the vacuum actuator.

- (1) Disconnect the vacuum hose from the vacuum actuator, and then connect a hand vacuum pump to the vacuum actuator.
- (2) Apply a vacuum and check that the throttle lever moves and the vacuum is maintained.

Q: Is the vacuum actuator damaged?

YES : Replace the vacuum actuator. Refer to GROUP 13A, Throttle Body Assembly [P.13Aa-28.](#) Then check that the malfunction is eliminated.

NO : Check that the malfunction is eliminated. If the malfunction is eliminated, replace the auto-cruise control-ECU. (Refer to [P.17-105.](#)) Then check that the malfunction is eliminated.

INSPECTION PROCEDURE 8: Auto-cruise Control Indicator Light inside Combination Meter does not illuminate. (However, Auto-cruise Control is Normal.)

Auto-cruise Control Indicator Light Drive Circuit

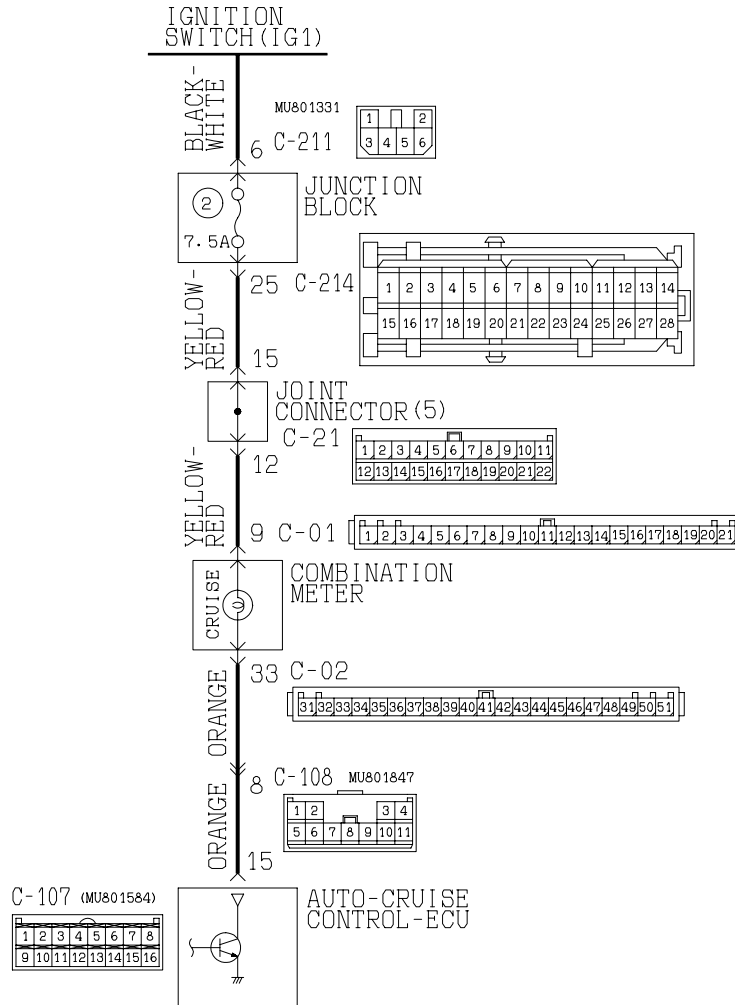

W2J09M00AA

cardiagn.com

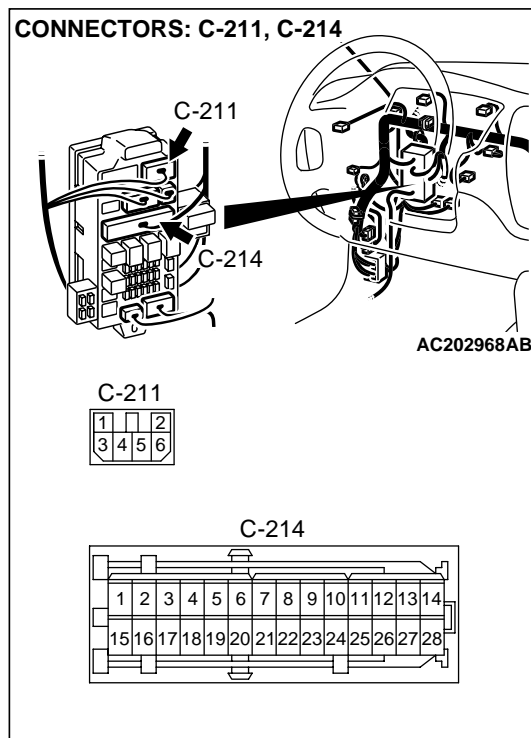
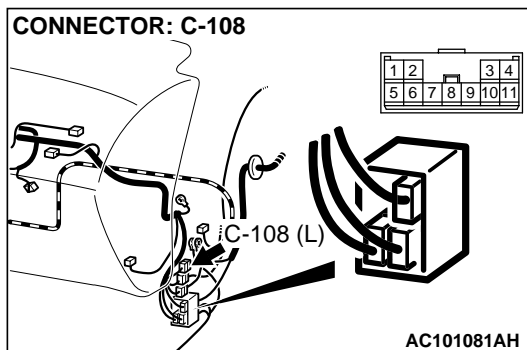
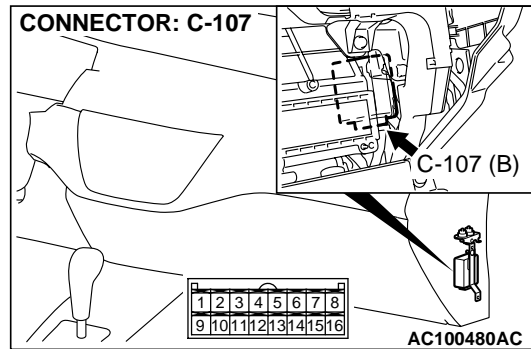
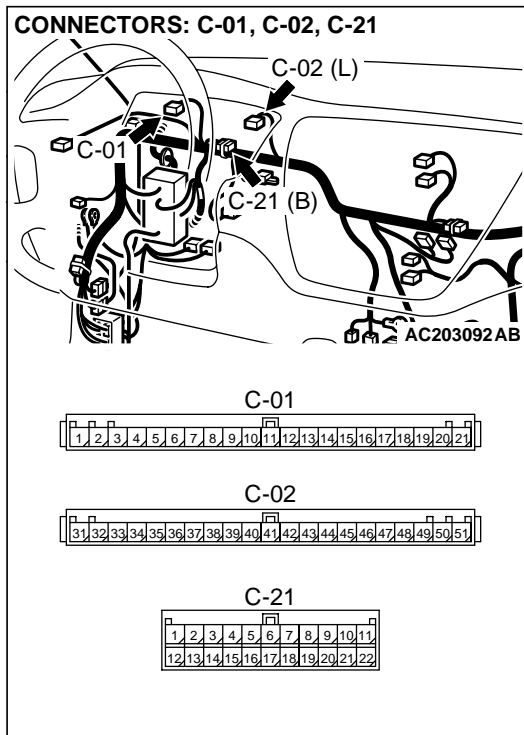

CIRCUIT OPERATION

The power for the auto-cruise indicator in the combination meter is supplied from the ignition switch (IG1). When the auto-cruise control system is operating, the transistor inside the auto-cruise control-ECU illuminates the auto-cruise indicator through ECU terminal number 15.

TECHNICAL DESCRIPTION (COMMENT)

The cause is probably the malfunction of the indicator bulb or the malfunction of the connector or harness.

TROUBLESHOOTING HINTS

- Malfunction of the indicator bulb.
- Damaged harness or connector.
- Malfunction of the auto-cruise control-ECU.

DIAGNOSIS**Required Special Tool:**

- MB991223: Harness Set

STEP 1. Check the auto-cruise control indicator bulb.

- (1) Remove the combination meter. Refer to GROUP 54A, Combination Meter Assembly and Vehicle Speed Sensor P.54A-42.
- (2) Check the auto-cruise control indicator bulb.

Q: Is the bulb blown?

YES : Replace the bulb. Then check that the malfunction is eliminated.

NO : Go to Step 2.

STEP 2. Measure the signal voltage at auto-cruise control-ECU connector C-107 by backprobing.

- (1) Remove the auto-cruise control-ECU mounting nut. Refer to P.17-105.
- (2) Do not disconnect auto-cruise control-ECU connector C-107.
- (3) Turn the ignition switch to the "ON" position.

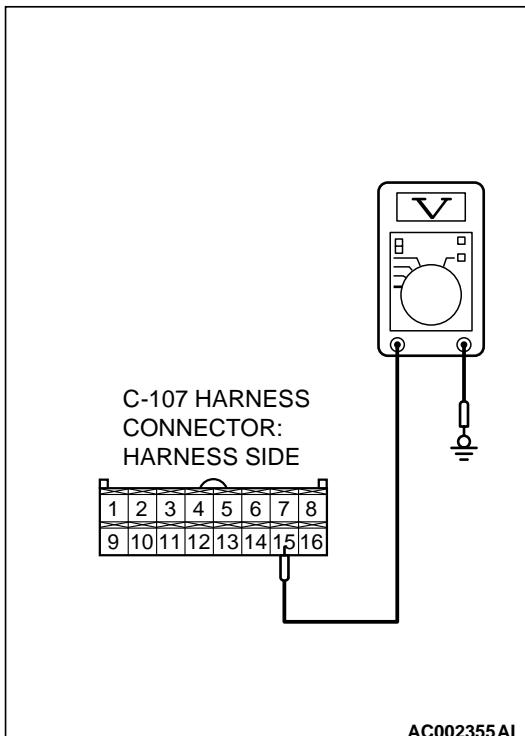
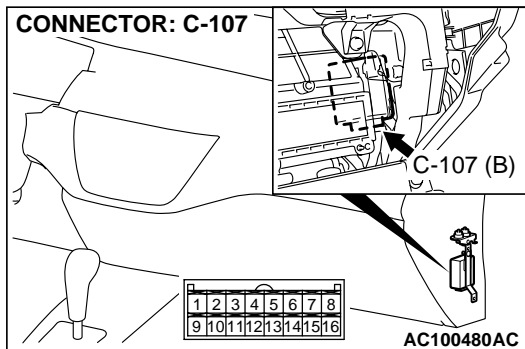

- (4) Measure the voltage between auto-cruise control-ECU connector C-107 terminal 15 and ground by backprobing.
 - The measured voltage should measure battery positive voltage.
- (5) Turn the ignition switch to the "LOCK" (OFF) position.

Q: Is the measured voltage battery positive voltage?

YES : Check that the malfunction is eliminated. If the malfunction is eliminated, replace the auto-cruise control-ECU. (Refer to P.17-105.) Then check that the malfunction is eliminated.

NO : Go to Step 3.

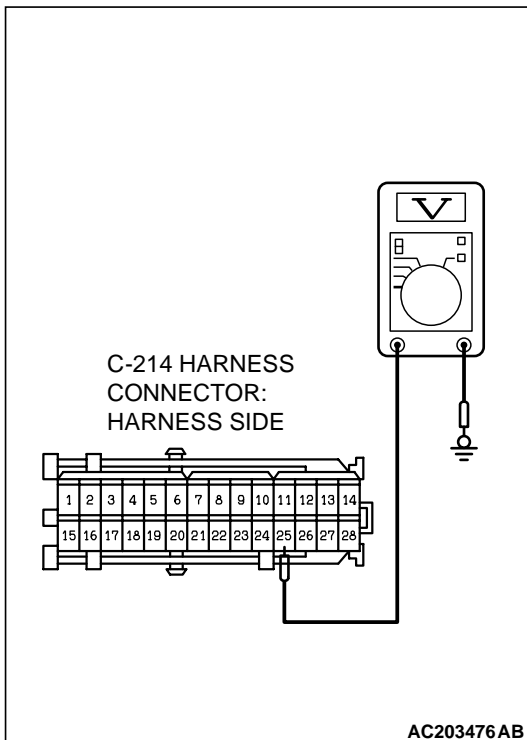
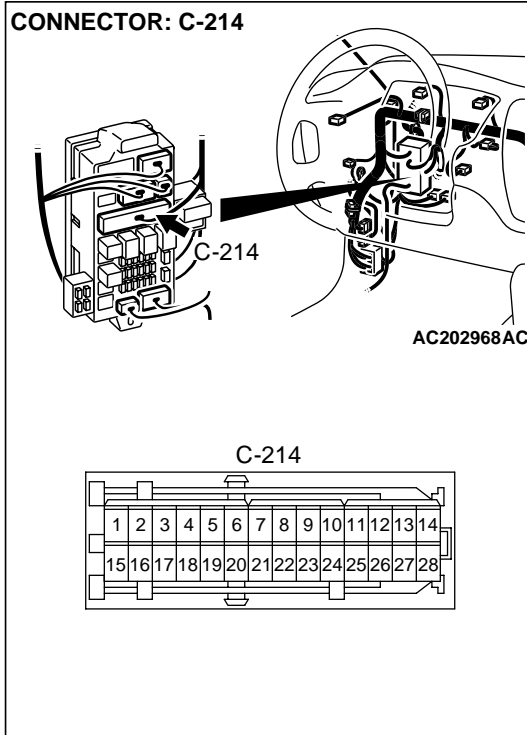

STEP 3. Measure the signal voltage at junction block connector C-214 by backprobing.

- (1) Do not disconnect junction block connector C-214.
- (2) Turn the ignition switch to the "ON" position.

- (3) Measure the voltage between junction block connector C-214 terminal 25 and ground by backprobing.
 - The measured voltage should measure battery positive voltage.

- (4) Turn the ignition switch to the "LOCK" (OFF) position.

Q: Is the measured voltage battery positive voltage?

YES : Go to Step 5.

NO : Go to Step 4.

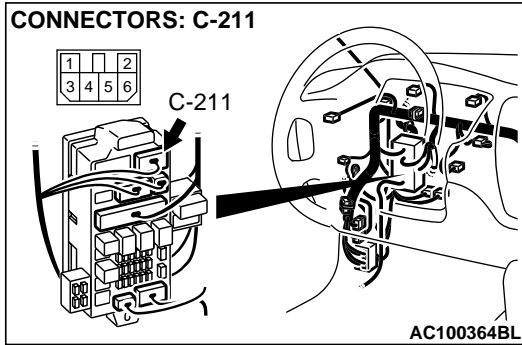

STEP 4. Check junction block connector C-211 for loose, corroded or damaged terminals, or terminals pushed back in the connector.

Q: Are the connector and terminals in good condition?

- YES :** Replace the junction block. Then check that the malfunction is eliminated.
- NO :** Repair or replace connector. Refer to GROUP 00E, Harness Connector Inspection [P.00E-2](#). Then check that the malfunction is eliminated.

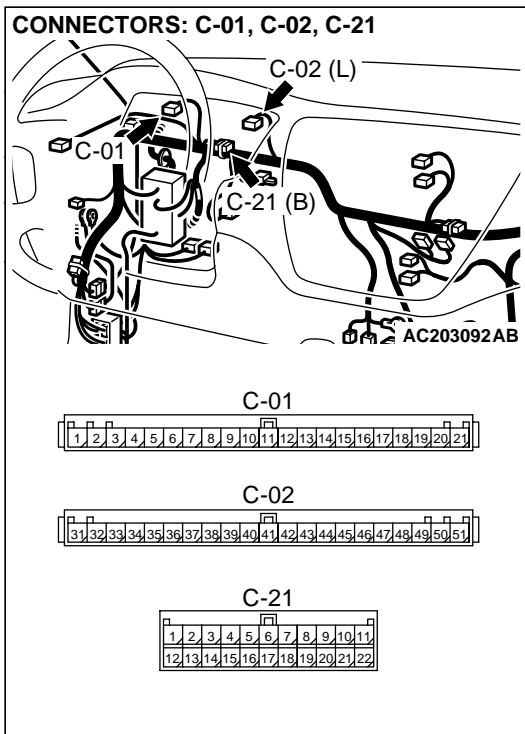

STEP 5. Check combination meter connectors C-01, C-02 and intermediate connector C-21 for loose, corroded or damaged terminals, or terminals pushed back in the connector.

Q: Are the connectors and terminals in good condition?

- YES :** Go to Step 6.
- NO :** Repair or replace connector. Refer to GROUP 00E, Harness Connector Inspection [P.00E-2](#). Then check that the malfunction is eliminated.

cardiagn.com

STEP 6. Check the harness wire between combination meter connector C-01 terminal 19 and junction block connector C-214 terminal 25 for damage.

Q: Is the harness wire in good condition?

YES : Go to Step 7.

NO : Repair the harness wire and then check that the malfunction is eliminated.

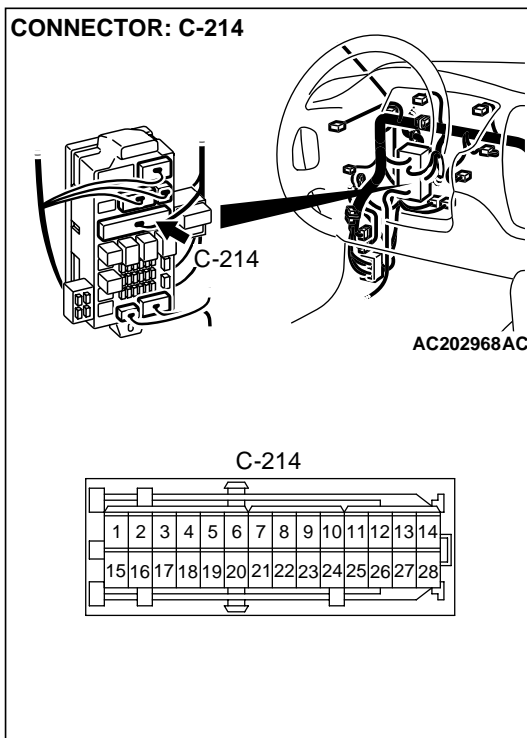
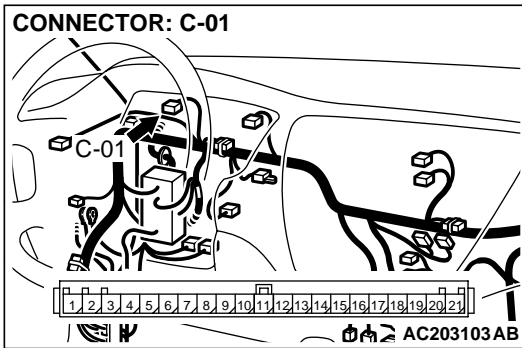

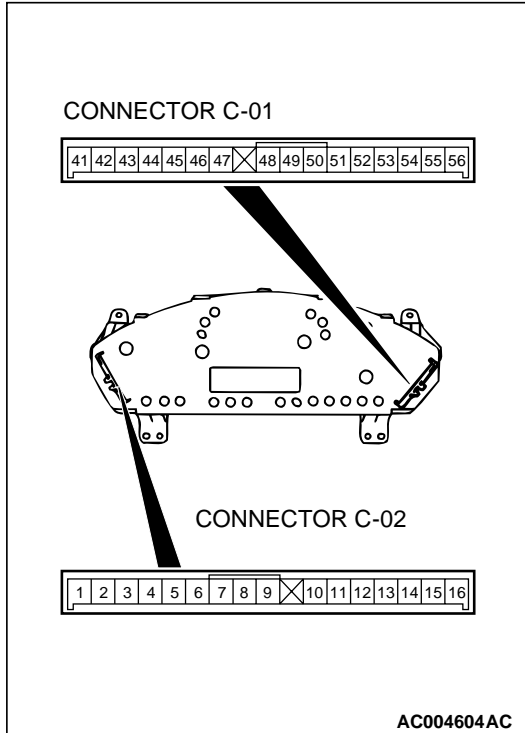
**STEP 7. Check the combination meter.**

- (1) Remove the combination meter and measure at the combination meter side. (Refer to GROUP 54A, Combination Meter Assembly and Vehicle Speed Sensor P.54A-42.)
- (2) Measure the continuity between combination meter C-01 terminal 9 and combination meter C-02 terminal 33.
 - The measured continuity should be less than 2 ohms.
- (3) Install the combination meter.

Q: Is the measured continuity less than 2 ohms?**YES :** Go to Step 8.**NO :** Replace the combination meter. Refer to GROUP 54A, Combination Meter Assembly and Vehicle Speed Sensor P.54A-42. Then check that the malfunction is eliminated.

STEP 8. Check auto-cruise control-ECU connector C-107 and intermediate connector C-108 for loose, corroded or damaged terminals, or terminals pushed back in the connector.

Q: Are the connectors and terminals in good condition?

YES : Go to Step 9.

NO : Repair or replace connector. Refer to GROUP 00E, Harness Connector Inspection [P.00E-2](#). Then check that the malfunction is eliminated.

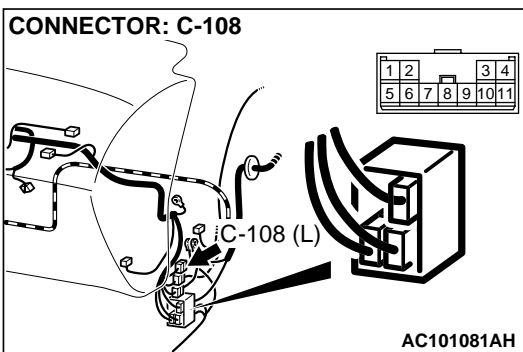
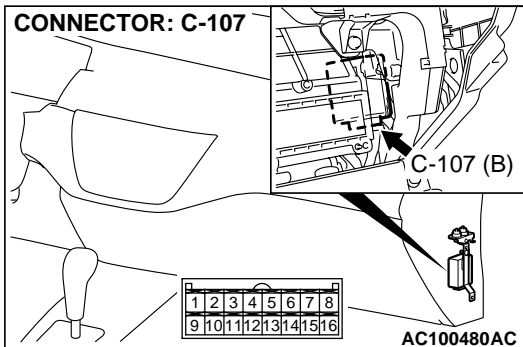

STEP 9. Check the harness wire between combination meter connector C-02 terminal 33 and auto-cruise control-ECU connector C-107 terminal 15 for damage.

Q: Is the harness wire in good condition?

YES : Check that the malfunction is eliminated. If the malfunction is eliminated, replace the auto-cruise control-ECU. (Refer to [P.17-105](#).) Then check that the malfunction is eliminated.

NO : Repair the harness wire and then check that the malfunction is eliminated.

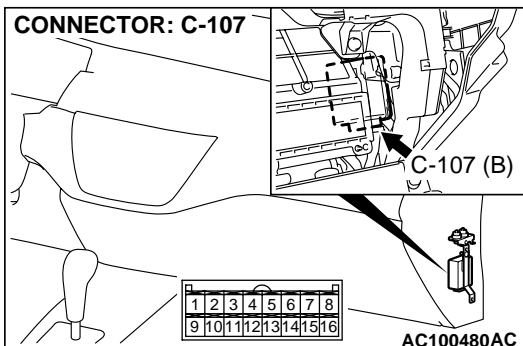
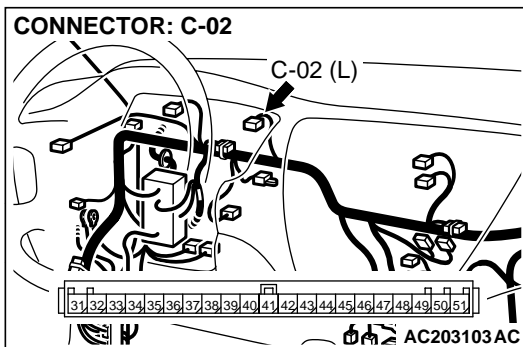

DATA LIST REFERENCE TABLE

M1172002400233

MUT-II SCAN TOOL DISPLAY	ITEM NO.	INSPECTION ITEM		INSPECTION REQUIREMENT	NORMAL CONDITION
CANCEL SWITCH	04	Auto-cruise control switch	CANCEL	CANCEL switch: "ON"	ON
				CANCEL switch: "OFF"	OFF
IDLE SW SIG	08	Closed throttle position switch		Accelerator pedal: Depressed	OFF
				Accelerator pedal: Released	ON
MAIN SW	01	Auto-cruise control switch	MAIN	MAIN switch: "ON"	ON
				MAIN switch: "OFF"	OFF
OD OFF	15	A/T control signal		No "OD-OFF" request	OFF
				"OD-OFF" request	ON
PNP SW/CLUTCH	14	Clutch pedal position switch <M/T>		Clutch switch: Depressed	ON
				Clutch switch: Released	OFF
		Park/neutral position switch <A/T>		Selector lever: "P" or "N" position	ON
				Selector lever: Other than "P" or "N" position	OFF
RESUME SWITCH	03	Auto-cruise control switch	RESUME	RESUME switch: "ON"	ON
				RESUME switch: "OFF"	OFF
SET SWITCH	02		SET	SET switch: "ON"	ON
				SET switch: "OFF"	OFF
STOPLIGHT SW	05	Stoplight switch		Brake pedal: Depressed	ON
				Brake pedal: Released	OFF
TP SENSOR	13	Throttle position sensor	Ignition switch: "ON"	Accelerator pedal: Released	335 – 935 mV
				Accelerator pedal: Depressed	Increases in proportion to throttle opening angle.
				Accelerator pedal: Fully depressed	4,390 – 5,290 mV
VSS	10	Vehicle speed sensor		Road test the vehicle	The speedometer and MUT-II display the same value.

CHECK AUTO-CRUISE CONTROL-ECU TERMINALS

M1172002700256

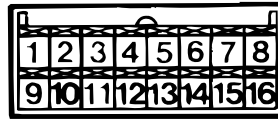

ACX02234

TERMINAL NO.	INSPECTION ITEM	INSPECTION CONDITIONS		NORMAL CONDITION
1	Throttle position sensor input	When accelerator pedal is fully depressed		4.0 – 5.5 V
		When accelerator pedal is released		0.4 – 1.0 V
2	Power train control module output (Idle switch)	When accelerator pedal is depressed		4.0 – 5.5 V
		When accelerator pedal is not depressed		2.5 V or less
3	A/T control output	Ignition switch: "ON" position		Battery positive voltage
4	Stoplight switch input	When brake pedal is depressed	When stoplight switch is ON	Battery positive voltage
		When brake pedal is not depressed	When stoplight switch is OFF	0 V
5	Pump power supply	Ignition switch: "ON" position Stoplight switch: OFF		10 V or more
6	ECU power supply	Ignition switch: "ON" position		Battery positive voltage
7	Release valve	When decelerating with the "SET" switch while driving at constant speed		1 V or less
8	Control valve			10 V or more
7	Release valve	When cancelling constant speed driving with the "CANCEL" switch		10 V or more
8	Control valve			Battery positive voltage
9	Auto-cruise control switch input	When main switch is "ON"		Approximately 7.0 V
		When input switch has not been operated	When all switches are OFF	3.5 – 5.0 V
		When input switch is pushed down	When "SET" switch is ON	0.4 – 2.3 V
		When input switch is pushed up	When "RESUME" switch is ON	2.3 – 3.5 V
		When input switch is pulled forward	When "CANCEL" switch is ON	0.4 V or less
10	Vehicle speed signal input	Ignition switch: "ON" position	Move the vehicle forward slowly	0 and 8 – 12 V alternate
12	ACC power supply	When ignition switch is in "ACC" position Main switch: "ON"		Battery positive voltage

cardiagn.com

TERMINAL NO.	INSPECTION ITEM	INSPECTION CONDITIONS		NORMAL CONDITION
13	Clutch pedal position switch input <M/T>	When pedal is not depressed	When clutch pedal position switch is OFF	Battery positive voltage
		When pedal is depressed	When clutch pedal position switch is ON	0 V
	Park/neutral position switch input <A/T>	When select lever is in a position other than N range	When park/neutral position switch is OFF	Battery positive voltage
		When select lever is in N range	When park/neutral position switch is ON	0 V
14	Ground	At any time		0 V
15	Indicator light input (inside combination meter)	When indicator light is illuminated		0 V
		When indicator light is switch off		Battery positive voltage
16	Auto-cruise vacuum pump motor input	When driving at constant speed using the "SET" switch	Motor stopped/running	Battery positive voltage/0 V
		When accelerating with the "RESUME" switch while driving at constant speed	Motor stopped/running	Battery positive voltage/0 V
		When decelerating with the "SET" switch while driving at constant speed	Motor stopped	Battery positive voltage
		When cancelling constant speed driving with the "CANCEL" switch	Motor stopped	Battery positive voltage

ON-VEHICLE SERVICE

AUTO-CRUISE CONTROL SWITCH CHECK

M1172001100217

1. Turn the ignition switch to the "ON" position.
2. Check that the indicator light within the combination meter illuminates when the main switch is switched "ON."

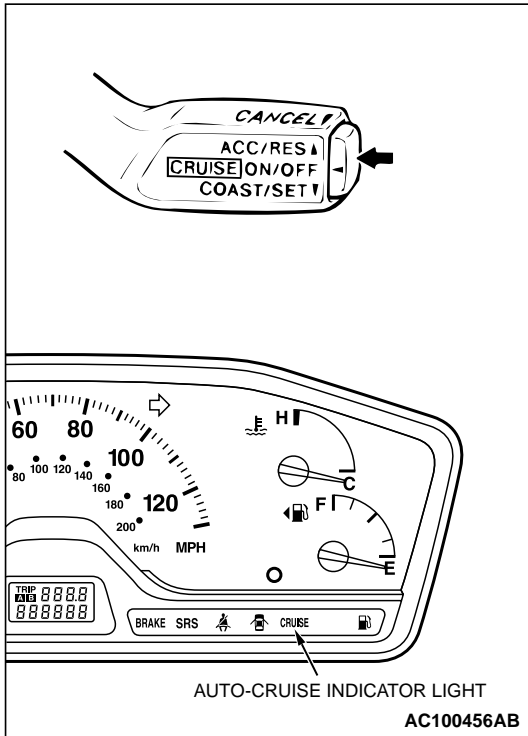

AUTO-CRUISE CONTROL SETTING

1. Switch "ON" the main switch.
2. Drive at the desired speed, above approximately 40 km/h. (25 mph)
3. Push the auto-cruise control switch in the direction of arrow.
4. Check to be sure that when the switch is released the speed is the desired constant speed.

NOTE: If the vehicles speed decreases to approximately 15 km/h (9 mph) below the set speed because of climbing a hill for example, the auto-cruise control will be cancelled.

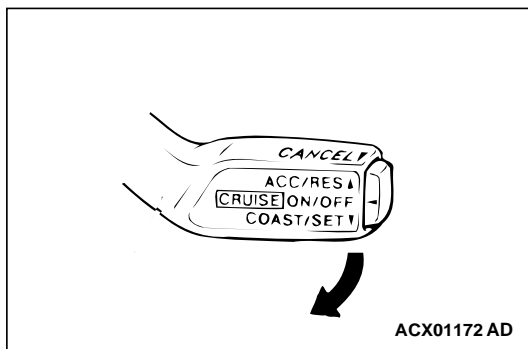

SPEED-INCREASE SETTING

1. Set to the desired speed.
2. Push the auto-cruise control switch in the direction of arrow.
3. Check to be sure that acceleration continues while the switch is held, and that after it is released the constant speed at the time when it was released becomes the driving speed.

NOTE: Acceleration can be continued even if the vehicle speed has passed the high-speed limit [approximately 200 km/h (124 mph)]. But the speed when the auto-cruise control switch is released will be recorded as the high-speed limit.

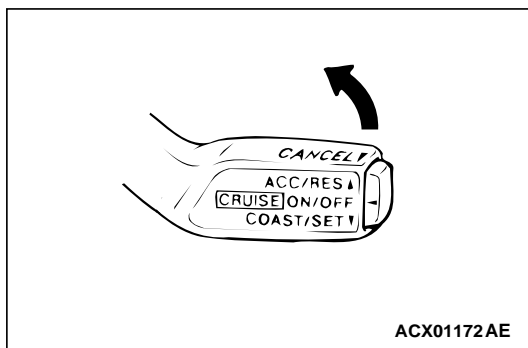

cardiagn.com

SPEED-REDUCTION SETTING

1. Set to the desired speed.
2. Push the auto-cruise control switch in the direction of arrow.
3. Check to be sure that deceleration continues while the switch is pressed, and that after it is released the constant speed at the time when it was released becomes the driving speed.

NOTE: When the vehicle speed reaches the low limit [approximately 40 km/h (25 mph)] during deceleration, the auto-cruise control will be cancelled.

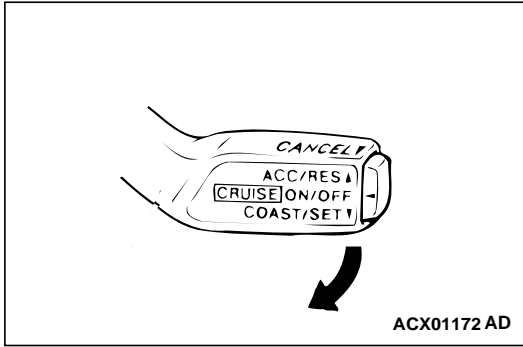

RETURN TO THE SET SPEED BEFORE CANCELLATION AND AUTO-CRUISE CONTROL CANCELLATION

1. Set the auto-cruise speed control.
2. When any of the following operations are performed while at constant speed during auto-cruise control, check if normal driving is resumed and deceleration occurs.
 - (1) The auto-cruise control switch is pushed in the direction of arrow.
 - (2) The brake pedal is depressed.
 - (3) The selector lever is moved to the "N" range.
3. At a vehicle speed of 40 km/h (25 mph) or higher, check if when the "RESUME" switch is switched "ON," the vehicle speed returns to the speed before auto-cruise control driving was cancelled, and constant speed driving occurs.
4. When the main switch is turned to "OFF" while driving at constant speed, check if normal driving is resumed and deceleration occurs.

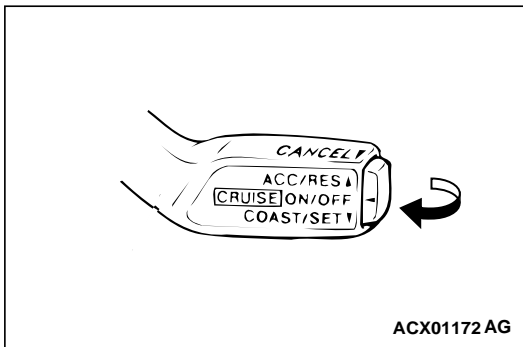

AUTO-CRUISE CONTROL SYSTEM COMPONENT CHECK

M1172001700220

STOPLIGHT SWITCH

1. Disconnect the connector.
2. Check for continuity between the terminals of the switch.

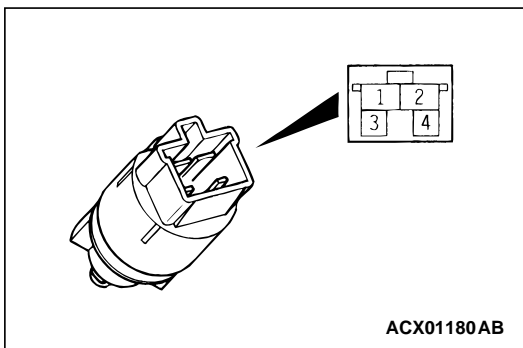

MEASUREMENT CONDITIONS	TERMINAL CONNECTOR OF TESTER	SPECIFIED CONDITION
When brake pedal is depressed. (for stoplight circuit)	1 - 2	Less than 2 ohms
	3 - 4	Open circuit
When brake pedal is not depressed. (for auto-cruise control circuit)	1 - 2	Open circuit
	3 - 4	Less than 2 ohms

CLUTCH PEDAL POSITION SWITCH <M/T>

1. Disconnect the connector.
2. Check for continuity between the terminals of the switch.

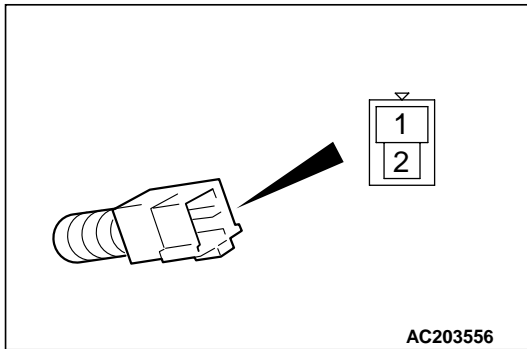

MEASUREMENT CONDITIONS	TERMINAL CONNECTOR OF TESTER	SPECIFIED CONDITION
When clutch pedal is depressed.	1 – 2	Less than 2 ohms
When clutch pedal is not depressed.	1 – 2	Open circuit

PARK/NEUTRAL POSITION SWITCH ("N" POSITIN) <A/T>

Refer to GROUP 23A, On-vehicle Service – Essential Service [P.23Aa-18](#).

THROTTLE POSITION SENSOR

Refer to GROUP 13A, On-vehicle Service – Throttle Position Sensor Check [P.13Aa-20](#).

AUTO-CRUISE VACUUM PUMP

1. Disconnect the vacuum hose from the auto-cruise vacuum pump and connect a vacuum gauge to the vacuum pump.
2. Disconnect the vacuum pump connector.
3. Check the auto-cruise vacuum pump and valves according to the following procedure:
 - (1) Connect the positive battery terminal to auto-cruise vacuum pump connector terminal 1, and the negative battery terminal to terminals 2, 3, and 4. Then the vacuum gauge should read 27 kPa (8.0 in Hg) or more.
 - (2) The vacuum should be maintained when terminal 4 is disconnected from the negative battery terminal while terminals 1, 2, and 3 remain connected. Then the vacuum gauge should read 0 kPa (0 in Hg) when terminal 2 is disconnected from the negative battery terminal while terminals 1, and 3 remain connected.
 - (3) The vacuum should be maintained when terminal 4 is disconnected from the negative battery terminal while terminals 1, 2, and 3 remain connected. Then the vacuum gauge should read 0 kPa (0 in Hg) when terminal 3 is disconnected from the negative battery terminal while terminals 1, and 2 remain connected.

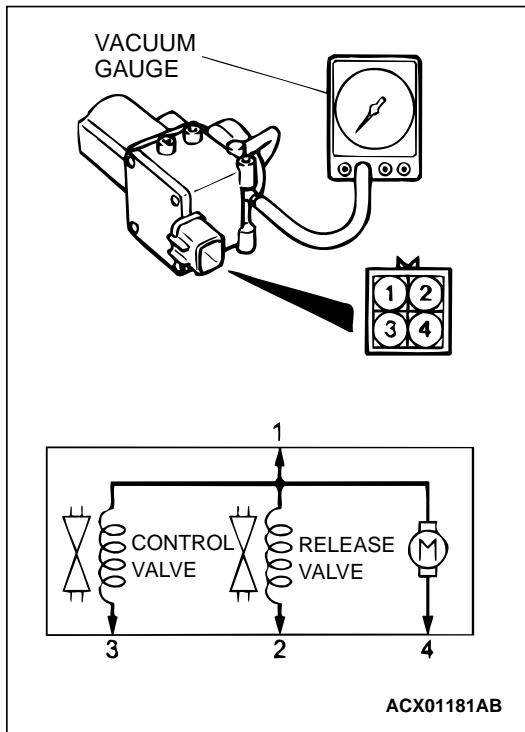

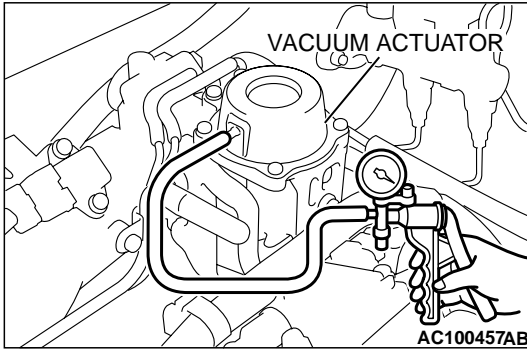

VACUUM ACTUATOR

1. Disconnect the vacuum hose from the vacuum actuator, and connect a hand vacuum pump to the actuator.
2. Check that the throttle lever operates when applying vacuum, and the vacuum is maintained.

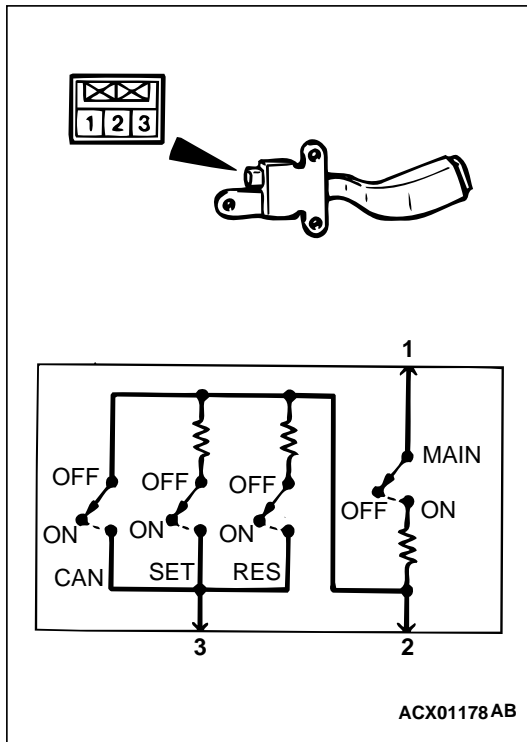

AUTO-CRUISE CONTROL CHECK

Measure the resistance between the terminals when each of the "SET," "RESUME," "CANCEL" and "MAIN" switches is pressed. If the values measured at the time correspond to those in the table below, the resistance values are correct.

SWITCH POSITION	RESISTANCE BETWEEN TERMINALS	
"MAIN" switch "OFF"	Terminals 1 and 2	Less than 2 ohms
"MAIN" switch "ON"	Terminals 1 and 2	Approximately 3.9 kΩ
"CANCEL" switch ON	Terminals 2 and 3	Approximately 0 Ω
"RESUME" switch ON	Terminals 2 and 3	Approximately 910 Ω
"SET" switch ON	Terminals 2 and 3	Approximately 220 Ω

VEHICLE SPEED SENSOR CHECK <M/T>

Refer to GROUP 54A, Combination Meters Assembly and Vehicle Speed Sensor [P.54A-42](#).

AUTO-CRUISE CONTROL
REMOVAL AND INSTALLATION
<ACTUATOR>

M1172001400207

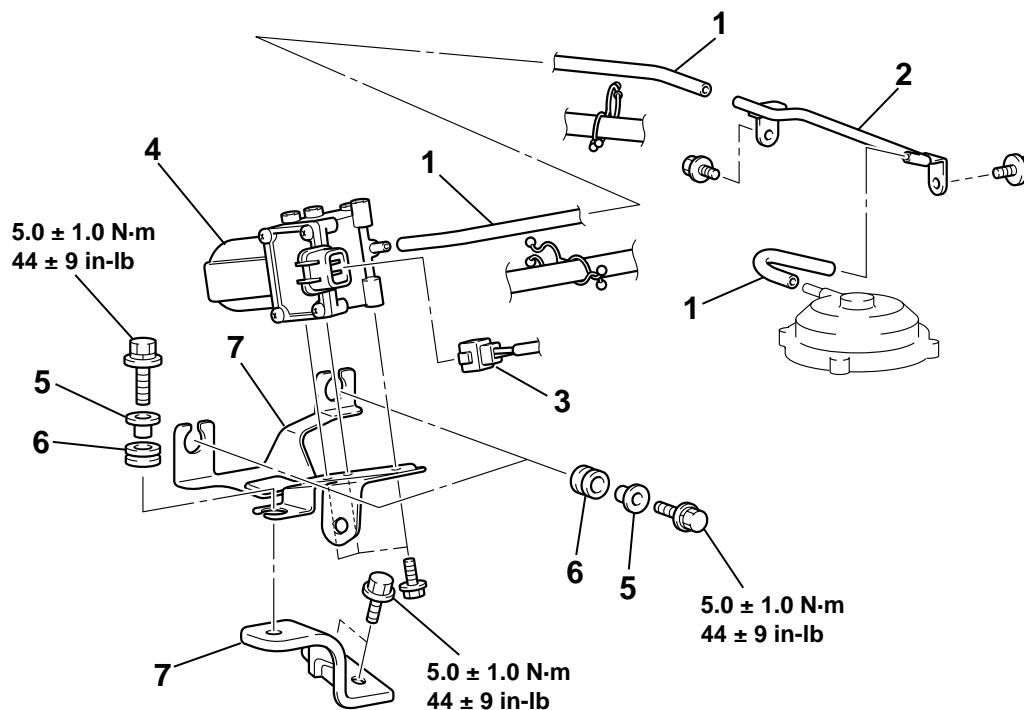

- REMOVAL STEPS**
1. VACUUM HOSE
 2. VACUUM PIPE
 3. WIRING CONNECTOR
 4. VACUUM PUMP ASSEMBLY

- AC100458AB
- REMOVAL STEPS (Continued)**
5. SPACER
 6. RUBBER MOUNT
 7. PUMP BRACKET

<SWITCHES, CONTROL UNIT AND SENSORS>

⚠ WARNING

Before removal of the air bag module, refer to **GROUP 52B, SRS Service Precautions and GROUP 52B, Air Bag Module and Clock Spring.**

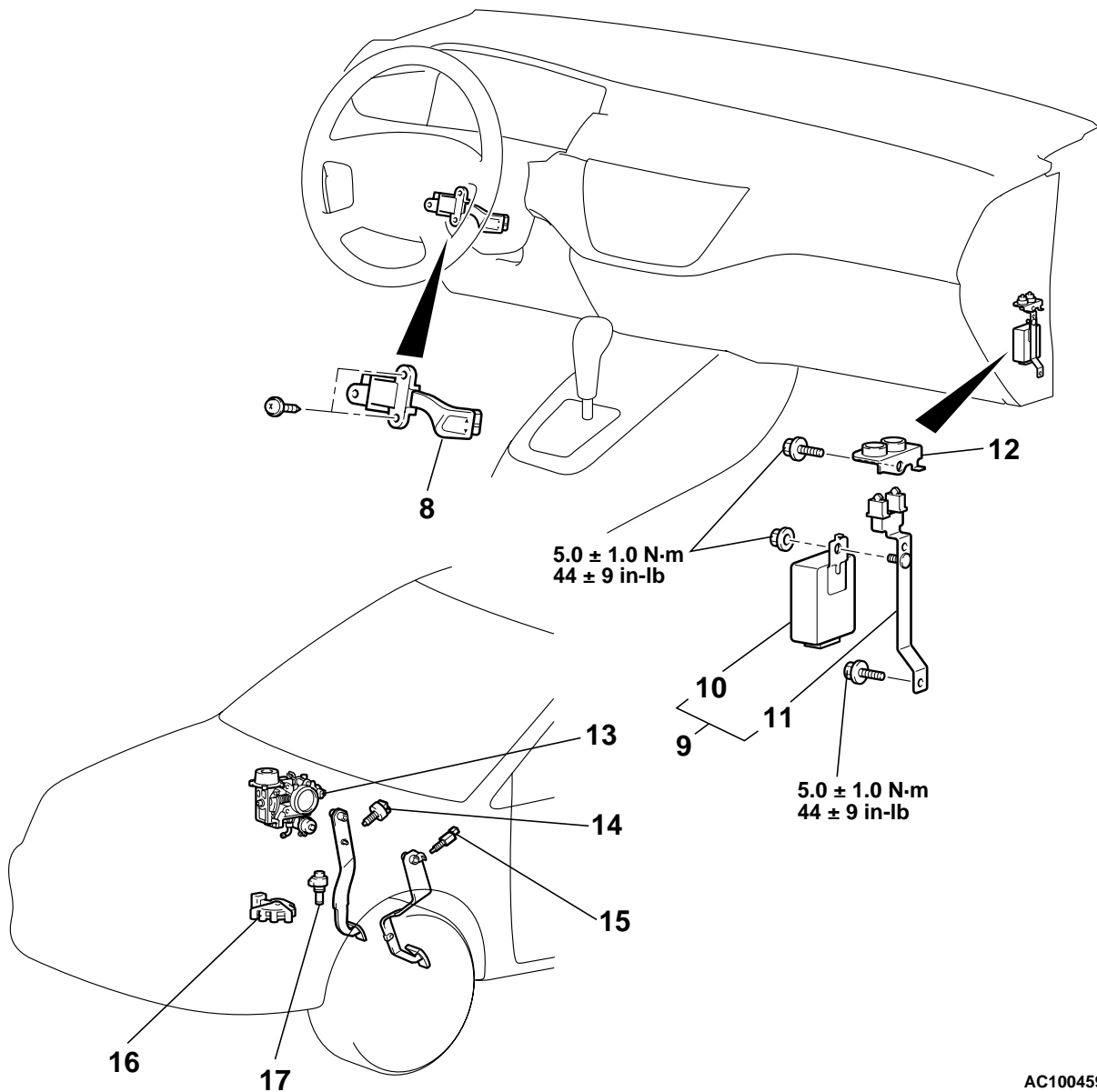

AC100459AB

CONTROL SWITCH REMOVAL STEPS

- STEERING WHEEL (REFER TO GROUP 37A, STEERING WHEEL AND SHAFT P.37A-20.)
- 8. AUTO-CRUISE CONTROL SWITCH

CONTROL UNIT REMOVAL STEPS

- GLOVE BOX (REFER TO GROUP52A, INSTRUMENT PANEL P.52A-2.)
- COWL SIDE TRIM (REFER TO GROUP52A, TRIMS P.52A-2.)
- 9. AUTO-CRUISE CONTROL-ECU AND BRACKET ASSEMBLY
- 10. AUTO-CRUISE CONTROL-ECU
- 11. LOWER BRACKET
- 12. UPPER BRACKET

SENSOR REMOVAL STEPS

13. THROTTLE POSITION SENSOR
14. STOPLIGHT SWITCH (REFER TO GROUP 35A, BRAKE PEDAL P.35A-27.)
15. CLUTCH PEDAL POSITION SWITCH <M/T> (REFER TO GROUP 21A, CLUTCH PEDAL P.35A-27.)
16. PARK/NEUTRAL POSITION SWITCH <A/T>
17. VEHICLE SPEED SENSOR <M/T>

EMISSION CONTROL

GENERAL DESCRIPTION

M1173000100080

The emission control system consists of the following subsystems:

- Positive crankcase ventilation system
- Evaporative emission control system
- Exhaust emission control system

DIAGNOSIS

M1173000700071

SYMPTOM	PROBABLE CAUSE	REMEDY
Engine will not start or hard to start	Vacuum hose disconnected or damaged	Repair or replace
	The EGR valve is not closed.	Repair or replace
	Malfunction of the evaporative emission purge solenoid	Repair or replace
Rough idle or engine stalls	The EGR valve is not closed.	Repair or replace
	Vacuum hose disconnected or damaged.	Repair or replace
	Malfunction of the positive crankcase ventilation valve	Replace
	Malfunction of the purge control system	Check the system; If there is a problem, check its component parts.
Engine hesitates or poor acceleration	Malfunction of the exhaust gas recirculation system	Check the system; If there is a problem, check its component parts.
Excessive oil consumption	Positive crankcase ventilation line clogged	Check positive crankcase ventilation system
Poor fuel mileage	Malfunction of the exhaust gas recirculation system	Check the system; If there is a problem, check its component parts.

SPECIAL TOOLS

M1173000600029

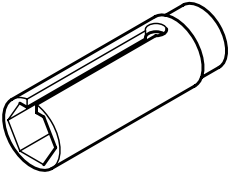
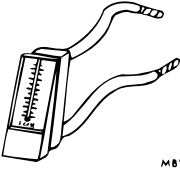
TOOL	TOOL NUMBER AND NAME	SUPERSESION	APPLICATION
	MD998770 Oxygen sensor wrench	MD998770-01 or General service tool	Removal/installation of heated oxygen sensor
	MB995061 Purge flow indicator	MLR6890A	Inspection of purge control system

VACUUM HOSES

VACUUM HOSE ROUTING

M1173000900105

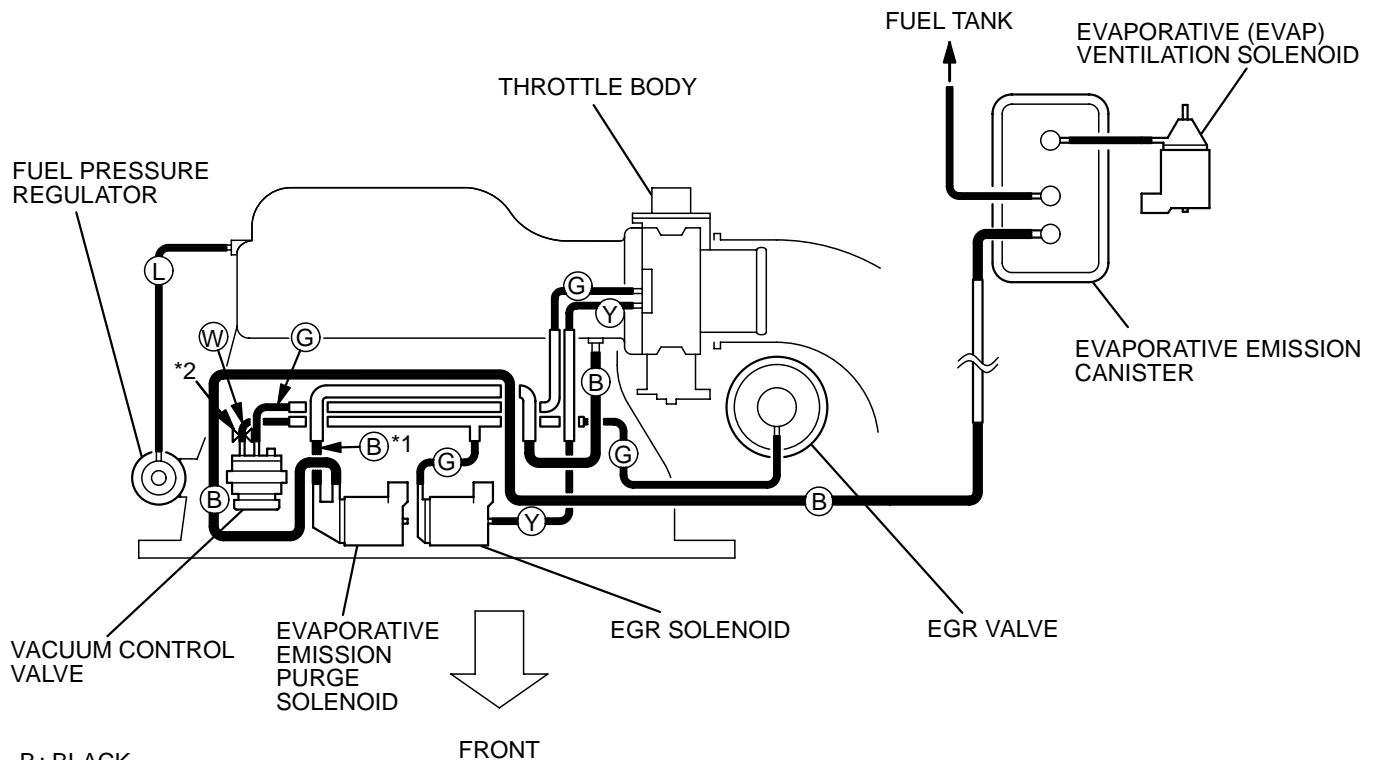

cardiagn.com

AK100056 AB

VACUUM CIRCUIT DIAGRAM

M1173007100069

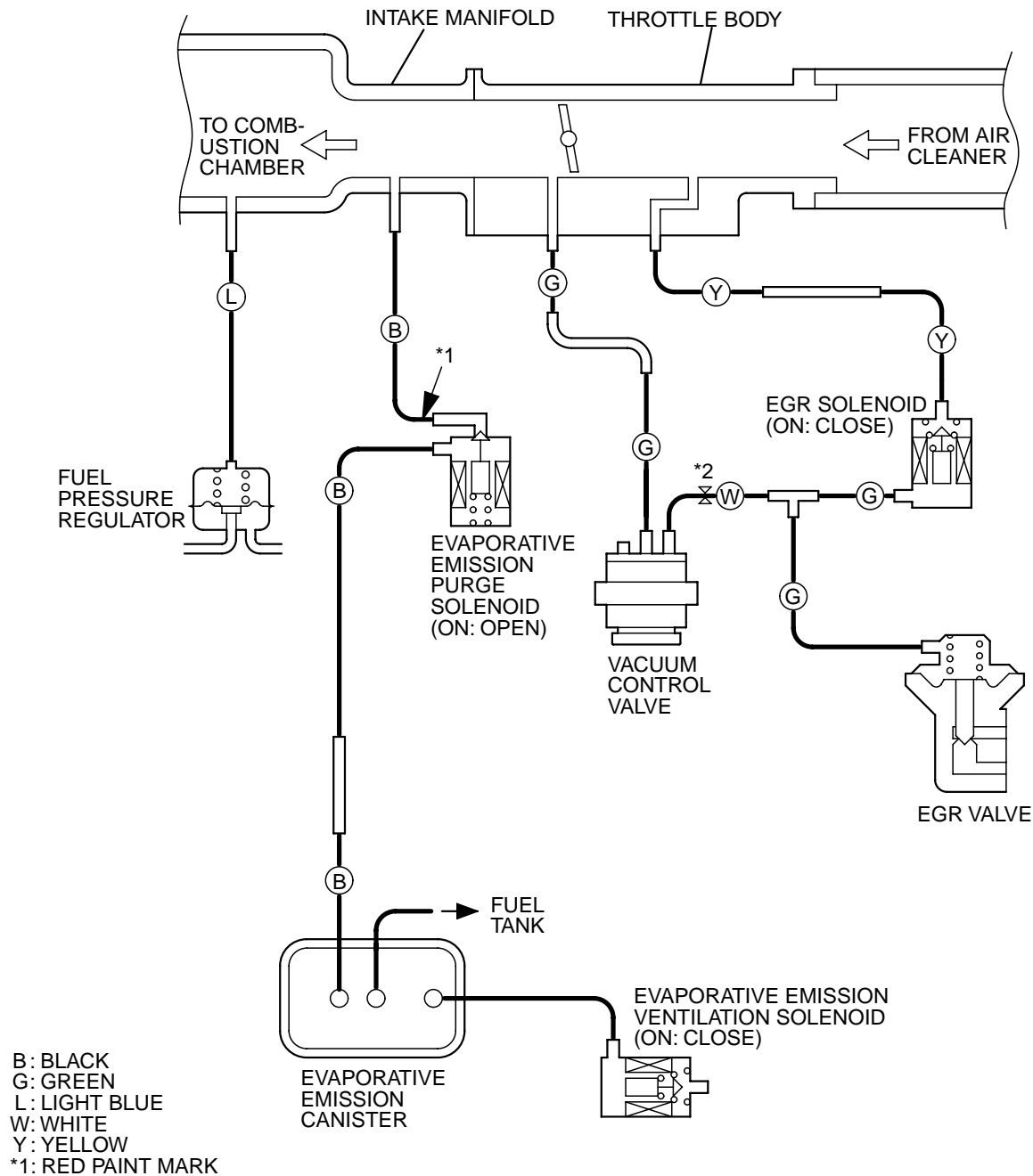

AK100067 AB

VACUUM HOSE INSTALLATION

M1173007200044

1. When connecting the vacuum hoses, they should be securely inserted onto the nipples.
2. Connect the hoses correctly, using the VACUUM HOSE ROUTING as a guide.

VACUUM HOSE CHECK

M1173007300052

1. Using the VACUUM HOSE ROUTING as a guide, check that the vacuum hoses are correctly connected.
2. Check the connection of the vacuum hoses, (removed, loose, etc.) and confirm that there are no sharp bends or damage.

POSITIVE CRANKCASE VENTILATION SYSTEM**GENERAL INFORMATION (POSITIVE CRANKCASE VENTILATION SYSTEM)**

M1173005000066

The positive crankcase ventilation system is a system for preventing the escape of blow-by gases from inside the crankcase into the atmosphere.

Fresh air is sent from the air cleaner into the crankcase through the breather hose to be mixed with the blow-by gas inside the crankcase.

The blow-by gas inside the crankcase is drawn into the intake manifold through the positive crankcase ventilation (PCV) valve.

The PCV valve is designed to lift the plunger according to the intake manifold vacuum so as to regulate the flow of blow-by gas properly.

In other words, the blow-by gas flow is regulated during low load engine operation to maintain engine stability, while the flow is increased during high load operation to improve the ventilation performance.

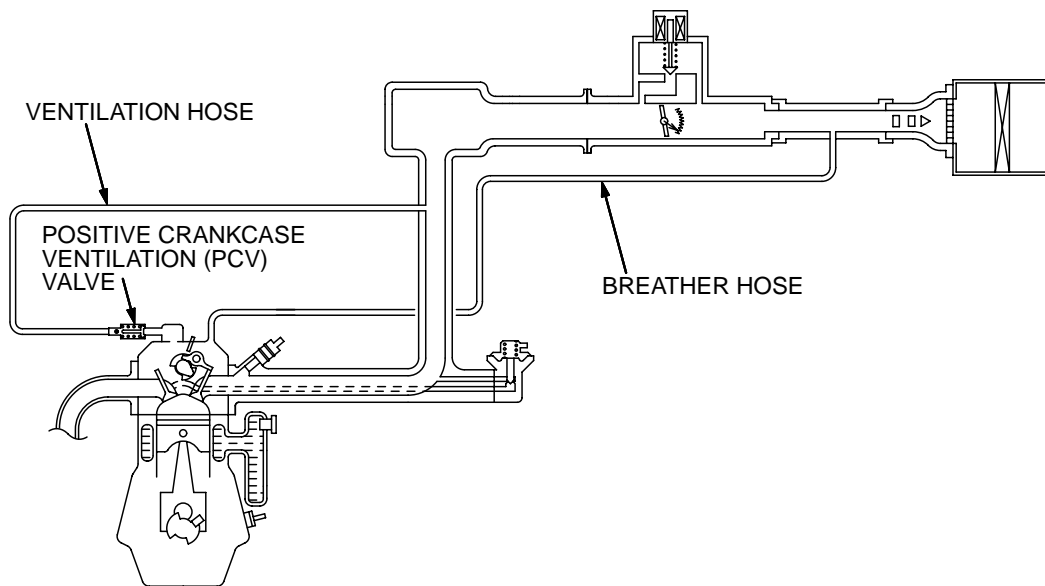
SYSTEM DIAGRAM

AK100085AB

COMPONENT LOCATION

M1173007400048

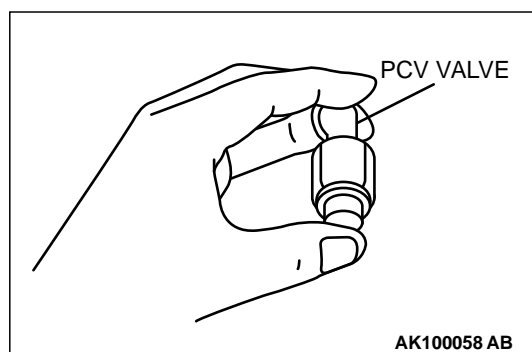
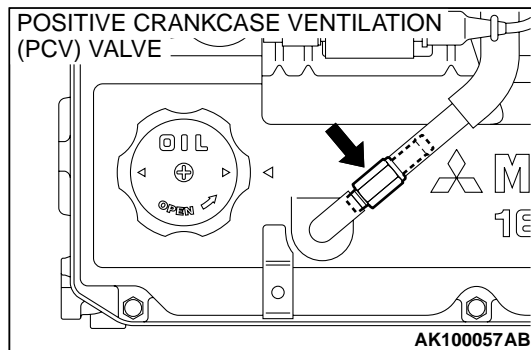

CRANKCASE VENTILATION SYSTEM CHECK

M1173001100083

1. Remove the positive crankcase ventilation (PCV) valve from the rocker cover, then reconnect the PCV valve to the vacuum supply hose.
2. With the engine idling, put your finger on the open end of the PCV valve, and check for negative pressure (vacuum).
NOTE: At this time, the plunger in the PCV valve should move back and forth as the open end is covered and uncovered.
3. If negative pressure is not felt, clean or replace the PCV valve. Inspect the vacuum supply hose and vacuum supply hose port for restriction or plugged condition.

POSITIVE CRANKCASE VENTILATION (PCV) VALVE CHECK

M1173001200079

1. Hold the PCV valve with the vacuum side down. Insert a thin rod, and using light pressure, depress the end of the PCV valve spring by 5 – 10 mm (0.2 – 0.3 inch). Release pressure on the rod to see if the PCV valve spring will lift the rod to its original position.
2. If the rod returns quickly to its original position, the PCV valve is OK. If the stick does not return quickly, clean or replace the PCV valve.

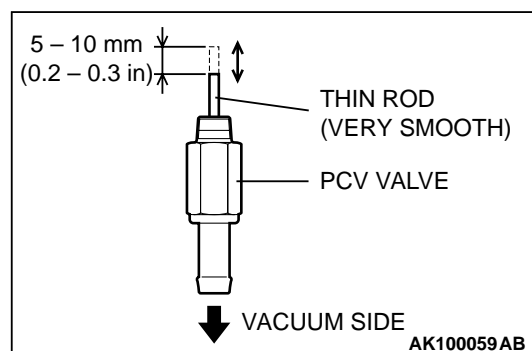

EVAPORATIVE EMISSION CONTROL SYSTEM

GENERAL INFORMATION

M1173005100085

The evaporative emission control system prevents fuel vapors generated in the fuel tank from escaping into the atmosphere.

Fuel vapors from the fuel tank flow through the vapor pipe/hose to be stored temporarily in the evaporative emission (EVAP) canister.

When the vehicle is in operation, fuel vapors stored in the EVAP canister flow the EVAP purge solenoid, purge port and intake manifold plenum to the combustion chamber.

When the engine coolant temperature is low or when the intake air quantity is small (when the engine is at idle, for example), the engine control module brings the EVAP purge solenoid into the OFF state to shut off the fuel vapor flow to the intake manifold plenum. This ensures driveability when the engine is cold or running under low load and also stabilizes the emission level.

An EVAP ventilation solenoid is provided between the EVAP canister and atmosphere to monitor for OBD-II EVAP leaks. This solenoid is normally OFF. However, it turns ON when monitoring the OBD-II EVAP leaks and shuts off the atmosphere flow to the

EVAP canister. Then the fuel tank differential pressure sensor monitors the fuel vapor pressure to detect OBD-II EVAP leaks. The fuel vent valve and the leveling valve prevent fuel from being overfilled. The fuel vent valve and the leveling valve prevents fuel leaks just if the vehicle is rolled over in an accident.

The vent valve releases the air from the fuel tank through the evaporative emission canister into the atmosphere when the fuel tank pressure increases due to refueling, etc. The vent valve and the air filter supply the atmospheric air to the evaporative emission canister when the fuel tank pressure decreases.

SYSTEM DIAGRAM

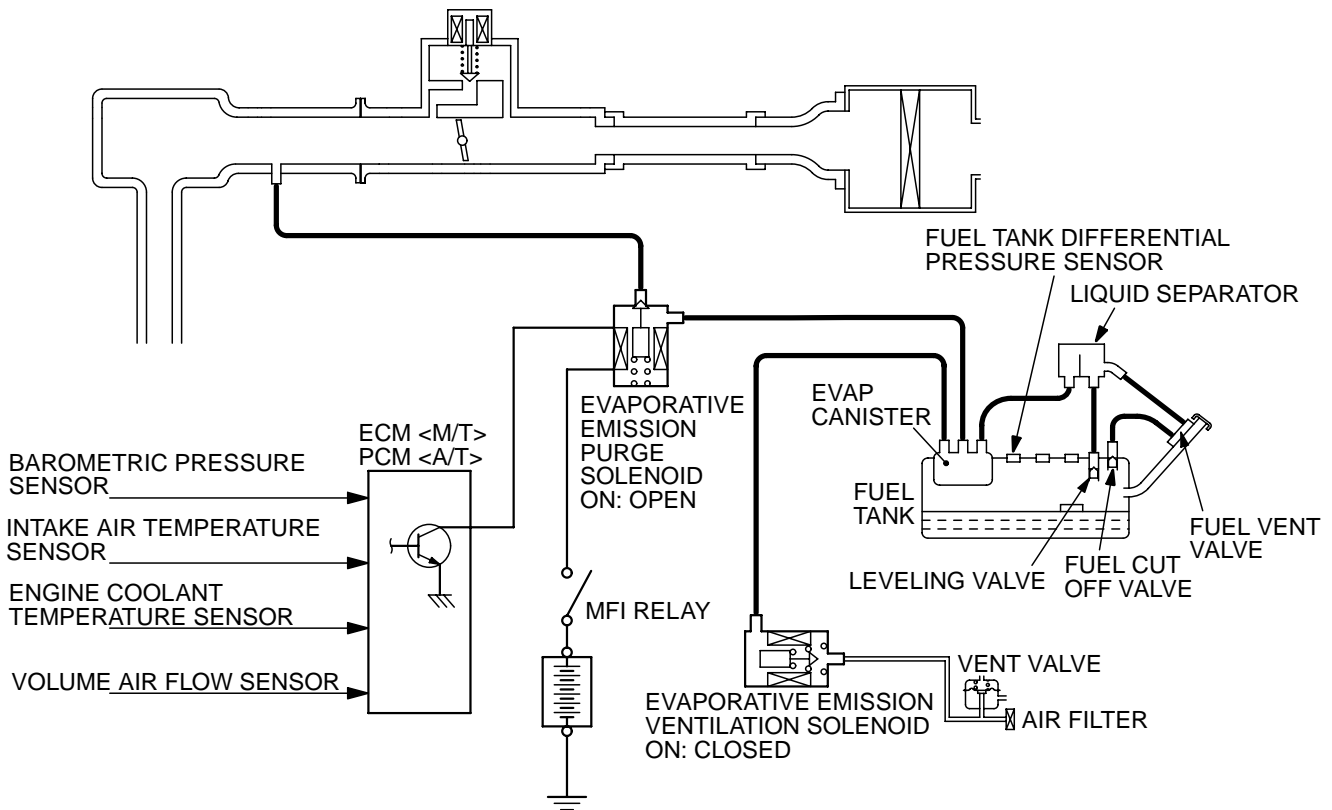

AK100068 AB

COMPONENT LOCATION

M1173007500056

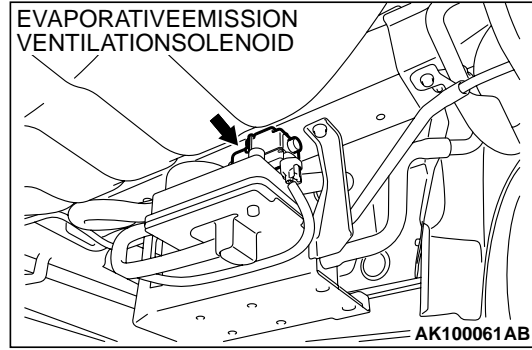
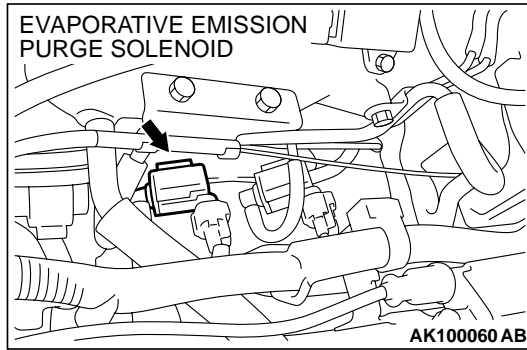

PURGE CONTROL SYSTEM CHECK (PURGE FLOW CHECK)

M1173001400062

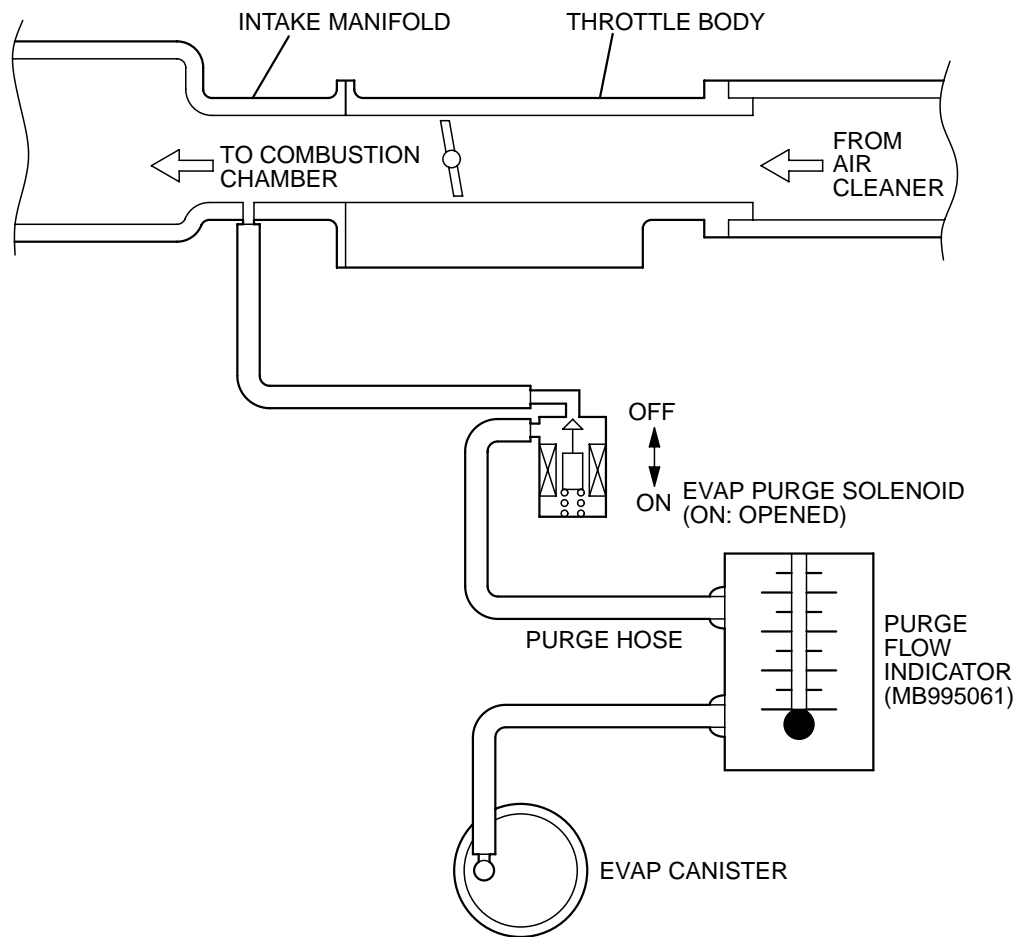

AKX00340AB

Required Special Tool:

MB995061: Purge Flow Indicator

1. Disconnect the purge hose from the evaporative emission (EVAP) purge solenoid, and connect special tool MB995061 between the EVAP purge solenoid and the purge hose.

2. Before inspection and adjustment, set the vehicle in the following conditions:
 - Engine coolant temperature: 80 – 95°C (176 – 203°F)
 - Lights, electric cooling fan and accessories: OFF
 - Transaxle: Neutral (A/T – P range)
3. Run the engine at idle for more than four minutes.
4. Check the purge flow volume when engine is revved suddenly several times.

Standard value: Momentarily 20 cm³/s (2.5 SCFH) or more.

5. If the purge flow volume is less than the standard value, check it again with the vacuum hose disconnected from the EVAP canister. If the purge flow volume is less than the standard value, check the vacuum port and the vacuum hose for clogging. Also check the evaporative emission purge solenoid. If the purge flow volume is at the standard value, replace the EVAP canister.

EVAPORATIVE EMISSION PURGE SOLENOID CHECK

M1173001700104

1. Disconnect the vacuum hose (black, black with red paint mark) from the EVAP purge solenoid.

NOTE: When disconnecting the vacuum hose, always place an identification mark so that it can be reconnected at its original position.

2. Disconnect the harness connector.
3. Connect a hand vacuum pump to nipple (A) of the EVAP purge solenoid (refer to the illustration at left).
4. As described in the chart below, check airtightness by applying a vacuum with voltage applied directly from the battery to the EVAP purge solenoid valve and without applying voltage.

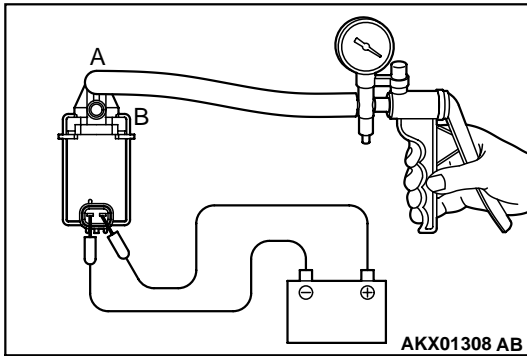

BATTERY POSITIVE VOLTAGE	NORMAL CONDITION
Applied	Vacuum leaks
Not applied	Vacuum maintained

5. Measure the resistance between the terminals of the EVAP purge solenoid.

Standard value: 30 – 34 Ω [at 20°C (68°F)]

6. Replace solenoid if resistance is out of specification.

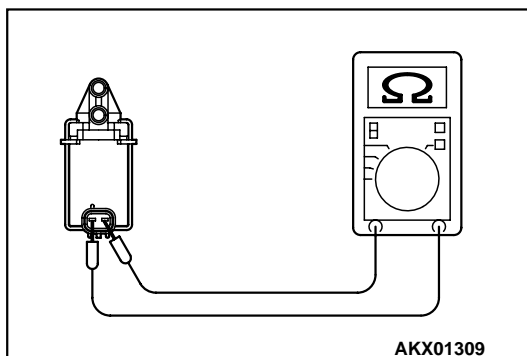

VOLUME AIR FLOW SENSOR CHECK

M1173007900292

To inspect the sensor, refer to GROUP 13A, Multiport Fuel Injection (MFI) Diagnosis – Diagnostic Trouble Code Chart [P.13Ab-19](#).

BAROMETRIC PRESSURE SENSOR CHECK

M1173008000140

To inspect the sensor, refer to GROUP 13A, Multiport Fuel Injection (MFI) Diagnosis – Diagnostic Trouble Code Chart [P.13Ab-19](#).

ENGINE COOLANT TEMPERATURE SENSOR CHECK

M1173008100299

To inspect the sensor, refer to GROUP 13A, Multiport Fuel Injection (MFI) Diagnosis – Diagnostic Trouble Code Chart [P.13Ab-19](#).

INTAKE AIR TEMPERATURE SENSOR CHECK

M1173008200144

To inspect the sensor, refer to GROUP 13A, Multiport Fuel Injection (MFI) Diagnosis – Diagnostic Trouble Code Chart [P.13Ab-19](#).

FUEL TANK DIFFERENTIAL PRESSURE SENSOR CHECK

M1173007700072

To inspect the sensor, refer to GROUP 13B, Fuel Supply – Fuel Tank – Fuel Tank Inspection – Fuel Tank Differential Pressure Sensor Check [P.13B-14](#).

EVAPORATIVE EMISSION VENTILATION SOLENOID CHECK

M1173007800079

Refer to Evaporative Emission Canister And Fuel Tank Pressure Relief Valve – Fuel Tank Pressure Relief Valve Inspection [P.17-120](#).

EXHAUST GAS RECIRCULATION (EGR) SYSTEM

GENERAL INFORMATION

M1173005200071

The exhaust gas recirculation (EGR) system lowers the oxides of nitrogen (NO_x) emission level. When the air/fuel mixture combustion temperature is high, a large quantity of NO_x is generated in the combustion chamber. Therefore, this system recirculates part of exhaust gas from the exhaust port of the cylinder head to the combustion chamber through the intake manifold to decrease the air/fuel mixture combustion temperature, resulting in reduction of NO_x. The EGR flow rate is controlled by the EGR valve so as not to decrease the driveability.

OPERATION

When the engine coolant temperature is low, when the engine is at idle or when a wide open throttle operation is performed, the EGR valve is kept closed, achieving no EGR. After warming up of the engine, the EGR valve can be opened by the engine control module. The engine control module monitors the EGR system and illuminates the check engine/malfunction indicator lamp to indicate that there is a malfunction.

SYSTEM DIAGRAM

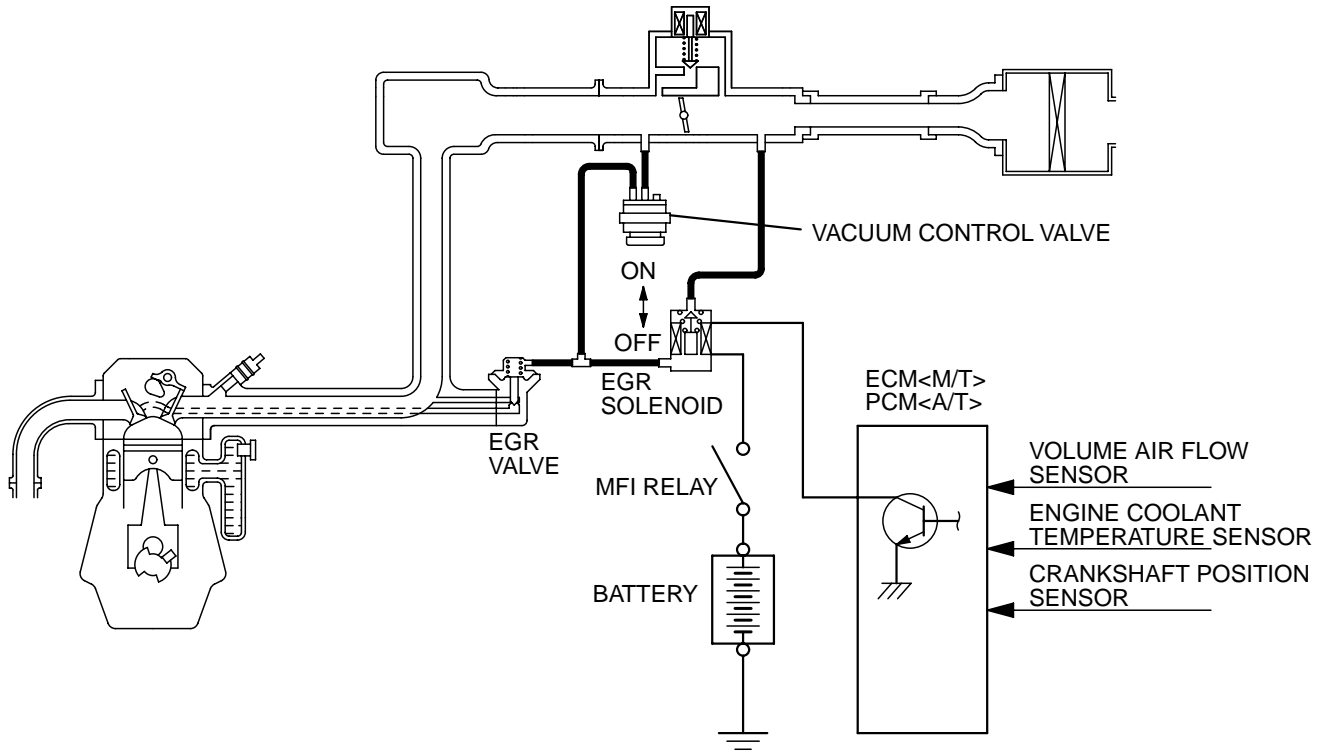

AK100086AB

COMPONENT LOCATION

M1173007600053

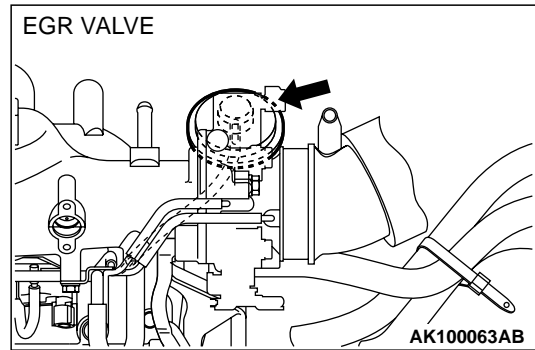
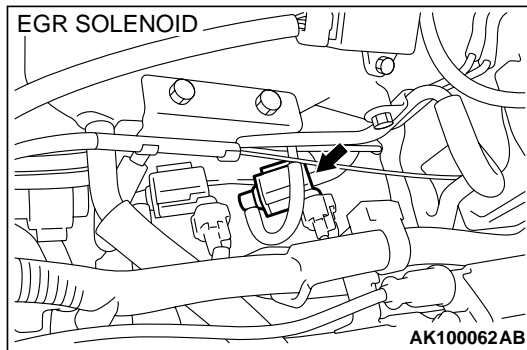

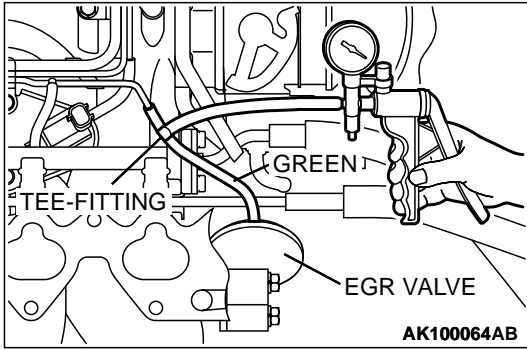

EGR SYSTEM CHECK

M1173002600199

1. Disconnect the vacuum hose (green) from the EGR valve, and then connect a hand vacuum pump via the Tee-fitting.
2. Start the engine. As described in the chart below, check the vacuum condition when the throttle valve is opened suddenly (revving) during cold and hot engine conditions. If the engine is hot and the vacuum does not rise over 13 kPa (3.9 in Hg), perform the vacuum control valve check and EGR port vacuum check. Then continue to Step 3. If vacuum rises momentarily, proceed to Step 3.

When engine is cold

[Engine coolant temperature: 20°C (68°F) or less]

THROTTLE VALVE	NORMAL VACUUM CONDITION
Open quickly	No vacuum (Remained as barometric pressure).

When engine is hot

[Engine coolant temperature: 80°C (176°F) or more]

THROTTLE VALVE	NORMAL VACUUM CONDITION
Open quickly	Momentarily rises over 13 kPa (3.9 in Hg)

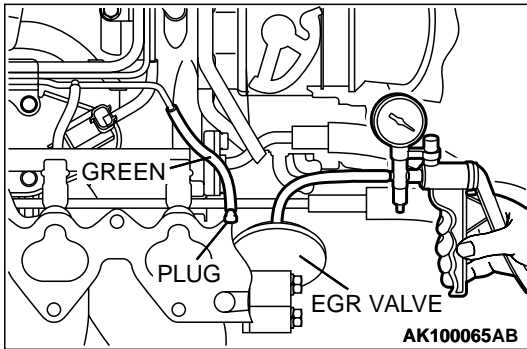

3. Stop the engine. Remove the Tee-fitting and the hand vacuum pump.
4. Connect the hand vacuum pump directly to the EGR valve.
5. Start the engine and run at idle until warm.
6. The engine idling speed should be rough when a vacuum of 27 kPa (7.9 in Hg) or more is applied to the EGR valve.
7. If engine idles rough, EGR passage is open and the system is OK. If engine idle is not rough, the EGR passage and the valve must be checked for restrictions. Perform the EGR valve check. Then repeat the EGR system check.

VACUUM CONTROL VALVE CHECK

M1173002700130

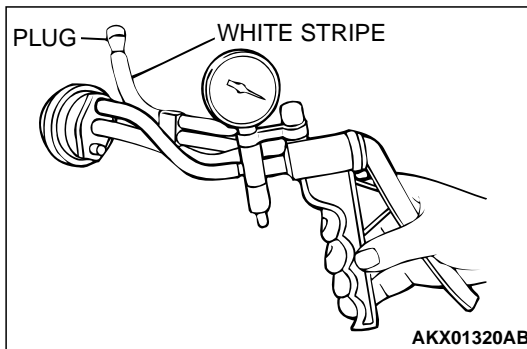

1. Disconnect the vacuum hose (white stripe) from the vacuum control valve and connect the hand vacuum pump to the vacuum control valve.
2. Plug the end of the removed vacuum hose.
3. Start the engine and run at idle.
4. As described in the chart below, check the vacuum condition.

ENGINE CONDITION	NORMAL VACUUM CONDITION
Idling	Approximately 21.3 – 24.0 kPa (6.3 – 7.1 in Hg)

EGR VALVE CHECK

M1173002800148

1. Remove the EGR valve and inspect for sticking, carbon deposits, etc. If found, clean with a suitable solvent so that the valve seats correctly.
2. Connect a hand vacuum pump to the EGR valve.
3. Apply 67 kPa (20 in Hg) of vacuum, and check to be sure that the vacuum is maintained.
4. As described in the chart below, apply a vacuum and check the passage of air by blowing through one side of the EGR passage.

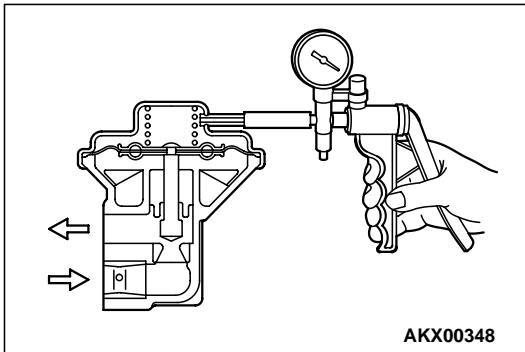

VACUUM	PASSAGE OF AIR
5.3 kPa (1.6 in Hg) or less	Air is not blown out
27 kPa (7.9 in Hg) or more	Air is blown out

NOTE: Passage of air should be checked by blowing the valve port.

5. Reinstall the EGR valve, using a new gasket, and tighten to the specified torque.

Tightening torque: 22 ± 4 N·m (16 ± 3 ft-lb)

EGR PORT VACUUM CHECK

M1173002900060

1. Disconnect the vacuum hose (green stripe) from the throttle body EGR vacuum nipple and connect a hand vacuum pump to the nipple.

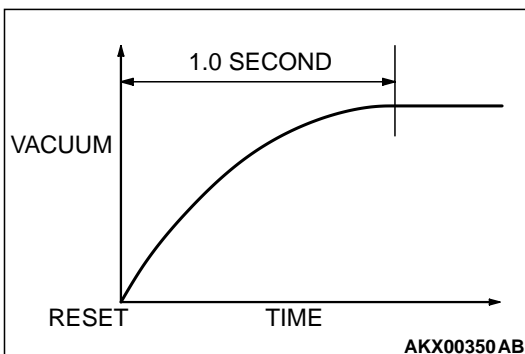
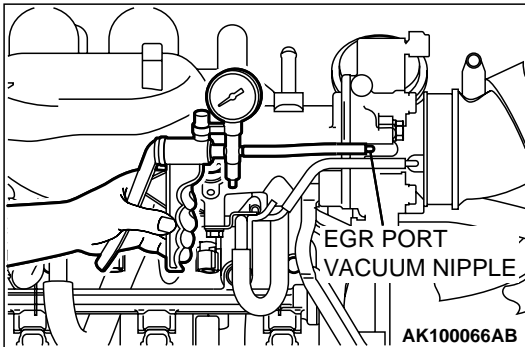

2. Start the engine.
3. Measure engine vacuum at idle.

Standard value: 51 kPa (15 in Hg) or more
4. Reset the vacuum pump to "0" (Release vacuum).
5. Using a stop watch, measure how long it takes for the vacuum gauge to reach 51 kPa (15 in Hg).

Standard value: 1.0 second or less
6. If it takes more than 1.0 second for the gauge to reach 51 kPa (15 in Hg), the EGR may be restricted and should be cleaned.

EGR SOLENOID CHECK

M1173003100131

1. Disconnect the vacuum hose from the EGR solenoid.
NOTE: When disconnecting the vacuum hose, always make sure that it can be reconnected at its original position.
2. Disconnect the harness connector.
3. Connect a hand vacuum pump to nipple (A) of the EGR solenoid. (Refer to the illustration at left.)
4. As described in the chart below, check airtightness by applying a vacuum with voltage applied directly from the battery to the EGR solenoid and without applying voltage.

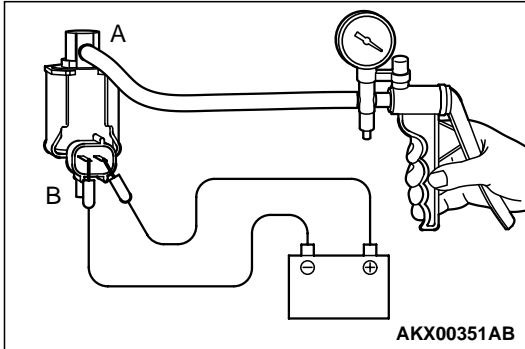

BATTERY POSITIVE VOLTAGE	NORMAL CONDITION
Not applied	Vacuum leaks
Applied	Vacuum maintained

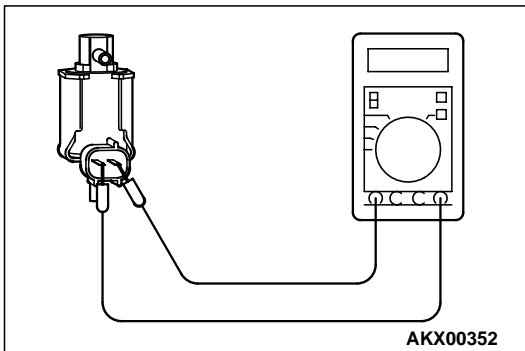

5. Measure the resistance between the terminals of the EGR solenoid.
Standard value: 29 – 35 Ω [at 20°C (68°F)]
6. Replace the solenoid if resistance is out of specification.

VOLUME AIR FLOW SENSOR CHECK

M1173007900300

To inspect the sensor, refer to GROUP 13A, Multiport Fuel Injection (MFI) Diagnosis – Diagnostic Trouble Code Chart [P.13Ab-19](#).

ENGINE COOLANT TEMPERATURE SENSOR CHECK

M1173008100307

To inspect the sensor, refer to GROUP 13A, Multiport Fuel Injection (MFI) Diagnosis – Diagnostic Trouble Code Chart [P.13Ab-19](#).

CRANKSHAFT POSITION SENSOR CHECK

M1173008300163

To inspect the sensor, refer to GROUP 13A, Multiport Fuel Injection (MFI) Diagnosis – Diagnostic Trouble Code Chart [P.13Ab-19](#).

EVAPORATIVE EMISSION CANISTER AND FUEL TANK PRESSURE RELIEF VALVE

REMOVAL AND INSTALLATION

M1173004800241

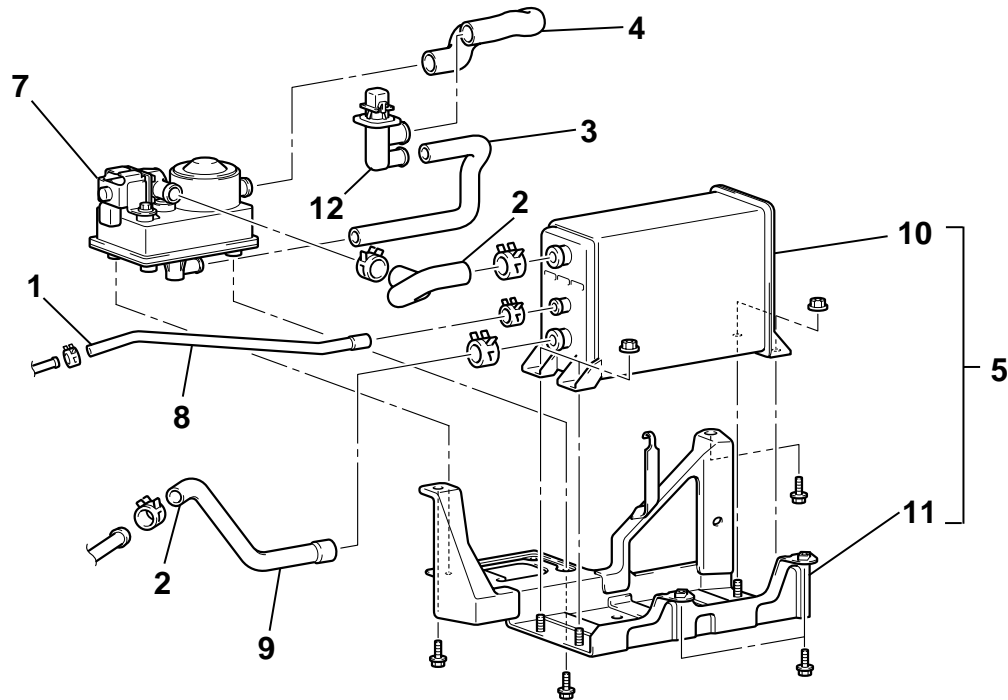

AC100460AB

REMOVAL STEPS

1. PURGE HOSE B CONNECTION
2. VAPOR HOSE CONNECTION
3. VENT HOSE C
4. VENT HOSE B
5. ON-BOARD REFUELING VAPOR RECOVERY (ORVR) VENT VALVE MODULE AND EVAPORATIVE EMISSION CANISTER ASSEMBLY
6. VENT HOSE A
7. ORVR VENT VALVE MODULE

REMOVAL STEPS (Continued)

8. PURGE HOSE B
9. VAPOR HOSE
10. EVAPORATIVE EMISSION CANISTER
11. BRACKET
12. VENT PIPE ASSEMBLY

INSPECTION

M1173004600184

ORVR VENT VALVE MODULE CHECK

1. Blow air through orvr vent valve module nipple (A). Check that the air flows out of nipple (B) and nipple (C).

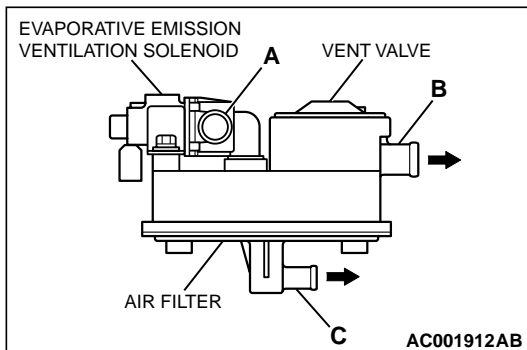

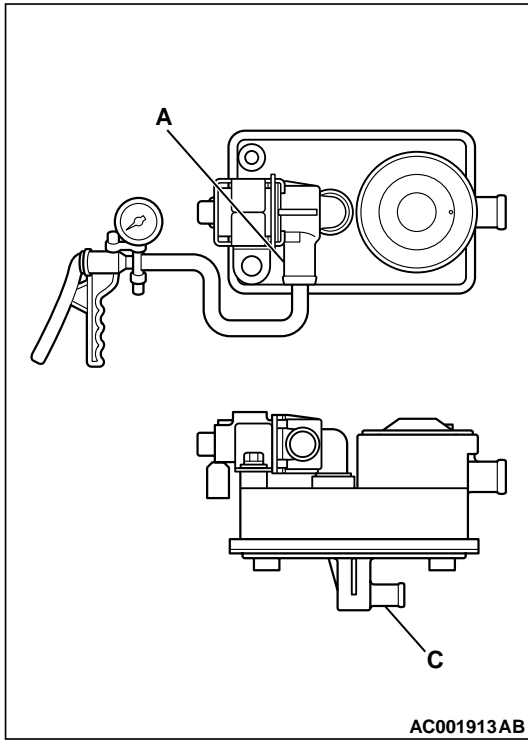

2. Connect a hand vacuum pump to nipple (A) of the orvr vent valve module.
3. With air flow through nipple (C) obstructed, apply a vacuum and check that the vacuum is maintained.

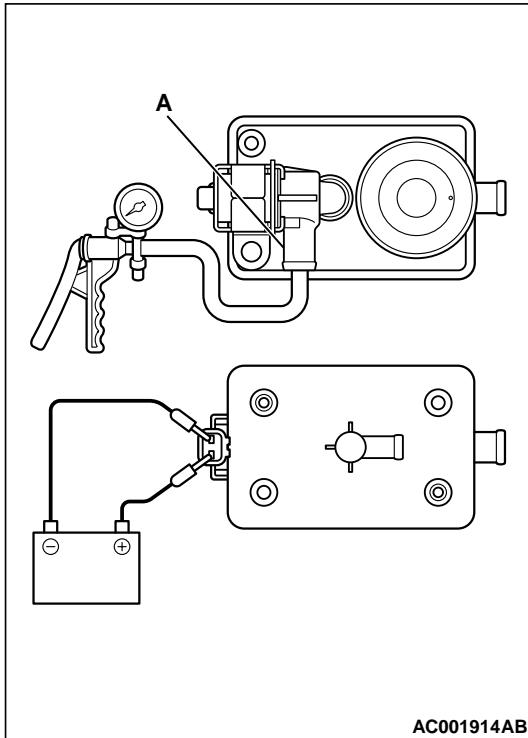

4. Check air tightness by applying a vacuum with voltage applied directly from the battery to the orvr vent valve module and without applying voltage.

BATTERY VOLTAGE	NORMAL CONDITION
Applied	Vacuum maintained
Not applied	Vacuum leaks

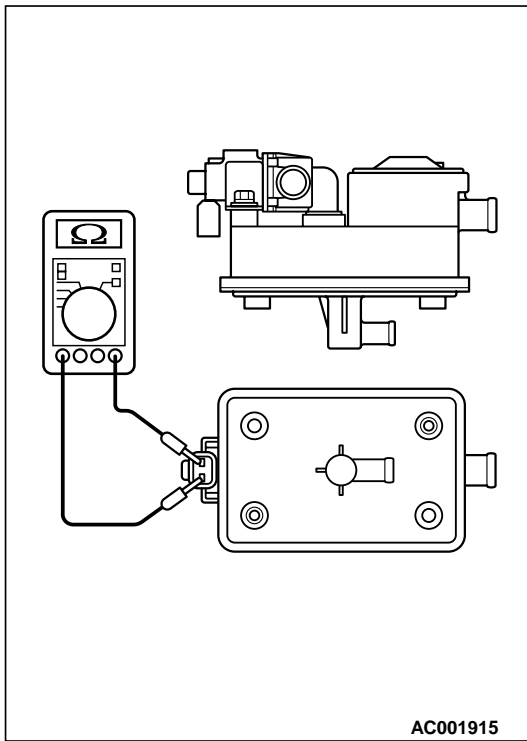

AC001915

5. Measure the resistance between the terminals of the solenoid.

Standard value: 17 – 21 Ω [at 20°C (68°F)]

6. Replace orvr vent valve module if resistance is out of specification.

CATALYTIC CONVERTER

GENERAL INFORMATION (CATALYTIC CONVERTER)

The three-way catalytic converter, together with the closed loop air-fuel ratio control based on the oxygen sensor signal, oxidizes carbon monoxides (CO) and hydrocarbons (HC) and reduces nitrogen oxides (NOx).

When the mixture is controlled at stoichiometric air-fuel ratio, the three-way catalytic converter provides the highest purification against the three constituents, namely, CO, HC and NOx.

M1173005300067

REMOVAL AND INSTALLATION

M1173003900104

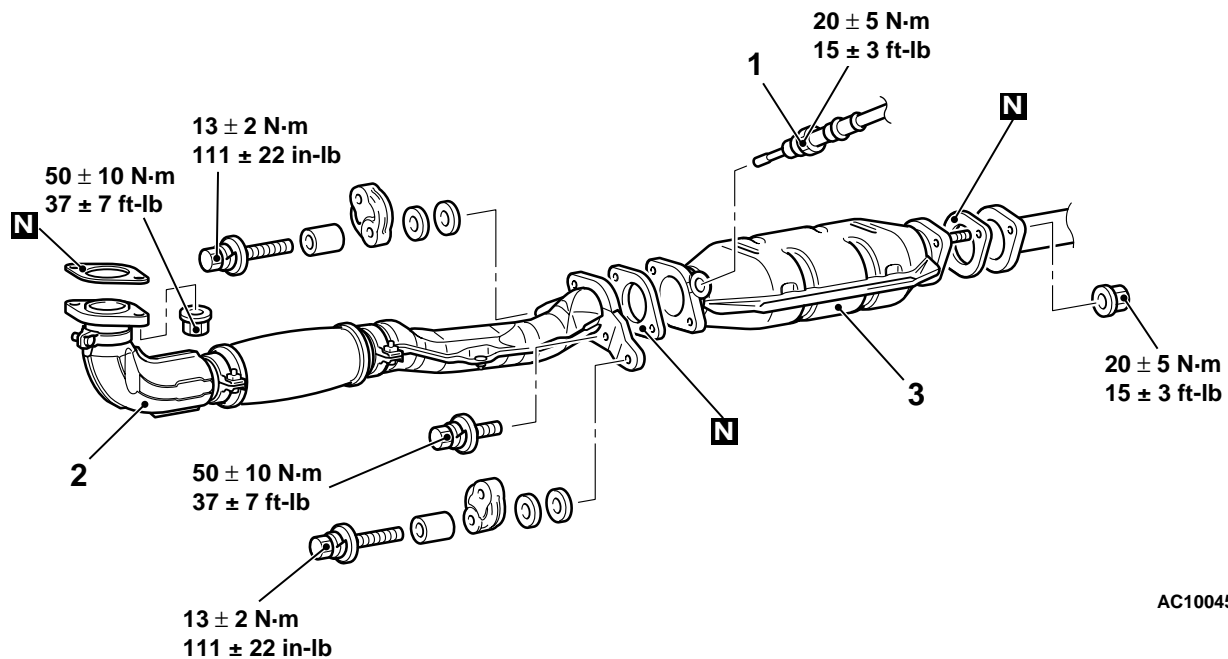

AC100454AB

- REMOVAL STEPS**
1. CATALYST TEMPERATURE SENSOR

- REMOVAL STEPS (Continued)**
2. FRONT EXHAUST PIPE
 3. CATALYTIC CONVERTER

SPECIFICATIONS

FASTENER TIGHTENING SPECIFICATIONS

M1173006400108

ITEMS	SPECIFICATIONS
Engine control system	
Accelerator cable attaching bolt	5.0 ± 1.0 N·m (44 ± 9 in-lb)
Accelerator cable clump attaching bolt	10 ± 2 N·m (89 ± 17 in-lb)
Accelerator pedal bracket installation nut	12 ± 2 N·m (102 ± 22 in-lb)
Auto-cruise control system	
Vacuum pump bracket attaching bolt	5.0 ± 1.0 N·m (44 ± 9 in-lb)
Auto-cruise control-ECU installation nut	5.0 ± 1.0 N·m (44 ± 9 in-lb)
Auto-cruise control-ECU bracket attaching bolt	5.0 ± 1.0 N·m (44 ± 9 in-lb)
Emission control system	
EGR valve bolt	22 ± 4 N·m (16 ± 3 ft-lb)
Catalyst temperature sensor	20 ± 5 N·m (15 ± 3 ft-lb)
Catalytic converter nut	20 ± 5 N·m (15 ± 3 ft-lb)
Front exhaust pipe nut	50 ± 10 N·m (37 ± 7 ft-lb)
Front exhaust pipe bolt	50 ± 10 N·m (37 ± 7 ft-lb)
Hanger bolt	13 ± 2 N·m (111 ± 22 in-lb)

SERVICE SPECIFICATIONS

M1173000300169

ITEMS	STANDARD VALUE
Engine control system	
Accelerator cable free play mm (in)	1 – 2 (0.04 – 0.08)
Curb idle speed r/min	700 ± 50
Emission control system	
EGR solenoid coil resistance [at 20°C (68°F)] Ω	29 – 35
Evaporative emission purge solenoid coil resistance [at 20°C (68°F)] Ω	30 – 34
Evaporative emission ventilation solenoid coil resistance [at 20°C (68°C)] Ω	17 – 21
Purge flow cm ³ /s (SCFH) [at 80 – 95°C (176 – 205°F) with sudden revving]	20 (2.5)

NOTES