

GROUP 13Aa

MULTIPOINT FUEL INJECTION (MFI)

CONTENTS

GENERAL DESCRIPTION	13Aa-2	THROTTLE POSITION SENSOR CHECK	13Aa-20
SPECIAL TOOLS	13Aa-5	HEATED OXYGEN SENSOR CHECK	13Aa-21
ON-VEHICLE SERVICE	13Aa-6	INJECTOR CHECK.....	13Aa-23
COMPONENT LOCATION	13Aa-6	IDLE AIR CONTROL MOTOR (STEPPER MOTOR) CHECK	13Aa-24
THROTTLE BODY CLEANING.....	13Aa-11	EVAPORATIVE EMISSION PURGE SOLENOID CHECK	13Aa-26
THROTTLE POSITION SENSOR ADJUSTMENT	13Aa-12	EGR SOLENOID CHECK	13Aa-26
FIXED SAS ADJUSTMENT	13Aa-12	EVAPORATIVE EMISSION VENTILATION SOLENOID CHECK	13Aa-26
BASIC IDLE SPEED ADJUSTMENT	13Aa-13	INJECTOR	13Aa-26
FUEL PRESSURE TEST	13Aa-14	REMOVAL AND INSTALLATION	13Aa-26
FUEL PUMP CONNECTOR DISCONNECTION (HOW TO REDUCE PRESSURIZED FUEL LINES)	13Aa-17	THROTTLE BODY ASSEMBLY	13Aa-28
FUEL PUMP OPERATION CHECK	13Aa-17	REMOVAL AND INSTALLATION	13Aa-28
MULTIPOINT FUEL INJECTION (MFI) RELAY CONTINUITY CHECK.....	13Aa-18	DISASSEMBLY AND ASSEMBLY	13Aa-30
FUEL PUMP RELAY CONTINUITY CHECK	13Aa-18	SPECIFICATIONS	13Aa-32
INTAKE AIR TEMPERATURE SENSOR CHECK	13Aa-19	FASTENER TIGHTENING SPECIFICATIONS.....	13Aa-32
ENGINE COOLANT TEMPERATURE SENSOR CHECK.....	13Aa-19	GENERAL SPECIFICATIONS	13Aa-33
		SERVICE SPECIFICATIONS	13Aa-34
		SEALANT AND ADHESIVE	13Aa-34

GENERAL DESCRIPTION

M1131000100370

The Multiport Fuel Injection System consists of sensors, actuators and the engine control module (ECM) <M/T> or powertrain control module (PCM) <A/T>. The sensors detect the engine condition. The module controls the system based on signals from these sensors. The actuators work under the control of the ECM <M/T> or PCM <A/T>. The ECM <M/T> or PCM <A/T> carries out activities such as fuel injection control, idle air control, and ignition timing control. In addition, the ECM <M/T> or PCM <A/T> is equipped with several diagnostic test modes which simplify troubleshooting when a problem develops.

FUEL INJECTION CONTROL

The ECM <M/T> or PCM <A/T> controls injection drive times and injector timing to supply the optimum air/fuel mixture to the engine according to the continually-changing engine operation conditions. A single injector is mounted at the intake port of each cylinder. The fuel pump supplies pressurized fuel from the fuel tank to the fuel injectors. The fuel pressure regulator controls the fuel pressure. Thus, the regulated fuel is distributed to each injector. Fuel is normally injected for each cylinder every two rotations of the crankshaft. The firing order is 1-3-4-2. Each cylinder has a dedicated fuel injector. This is called "multiport". The ECM <M/T> or PCM <A/T> provides a richer air/fuel mixture by carrying out "open-loop" control when the engine is cold or running under high load conditions. Thus, engine performance is maintained. In addition, when the engine is under normal operating temperature after warming-up, the ECM <M/T> or PCM <A/T> controls the air/fuel mixture according to the heated oxygen sensor signal. This control is a "closed-loop" control. The closed-loop control achieves the theoretical air/fuel mixture ratio where the catalytic converter can obtain the maximum cleaning performance.

IDLE AIR CONTROL

The engine control module controls the amount of air that bypasses the throttle valve according to changes in idling conditions and engine load during idling. Thus, idle speed is kept at an optimum speed. The ECM <M/T> or PCM <A/T> drives the idle air

control (IAC) motor according to engine coolant temperature, A/C, and other electrical load. Thus, idle speed is kept at an optimum speed. In addition, when the A/C switch is turned off and on while the engine is idling, the IAC motor adjusts the throttle valve bypass air amount. Thus, idle speed is maintained at constant speed regardless of various engine load conditions.

IGNITION TIMING CONTROL

The ignition power transistor located in the ignition primary circuit turns on and off to control primary current flow to the ignition coil. This maintains ignition timing at an optimum level regardless of various engine operating conditions. The ECM <M/T> or PCM <A/T> determines the ignition timing according to engine speed, intake air volume, engine coolant temperature, and atmospheric pressure.

DIAGNOSTIC TEST MODE

- When a fault is detected in any of the sensors or actuators related to emission control, the Malfunction Indicator Lamp (SERVICE ENGINE SOON) illuminates to warn the driver.
- When a fault is detected in one of the sensors or actuators, a diagnostic trouble code corresponding to the fault is stored in the ECM <M/T> or PCM <A/T>.
- The RAM data inside the ECM <M/T> or PCM <A/T> that is related to the sensors and actuators can be read with the scan tool. In addition, the actuators can be controlled by the scan tool MUT-II (MB991502) under certain circumstances.

OTHER CONTROL FUNCTIONS

Fuel Pump Control

- Turns the fuel pump relay ON so that current is supplied to the fuel pump while the engine is cranking or running.

A/C Compressor Clutch Relay Control

- Turns the compressor clutch of the A/C ON and OFF.

Fan Relay Control

- The radiator fan and condenser fan speeds are controlled in response to the engine coolant temperature and vehicle speed.

Generator Output Current Control

- Prevents generator output current from increasing suddenly and idle speed from dropping at times such as when the headlights are turned on.

Evaporative Emission Purge Control

- (Refer to GROUP 17, Emission Control System – Evaporative Emission Control System – General Information [P.17-111.](#))

EGR Control

- (Refer to GROUP 17, Emission Control System – Exhaust Gas Recirculation (EGR) System – General Information [P.17-115.](#))

MULTIPOINT FUEL INJECTION (MFI) SYSTEM DIAGRAM

SENSE

- ★ 1 HEATED OXYGEN SENSOR (FRONT)
 - ★ 2 VOLUME AIR FLOW SENSOR
 - ★ 3 INTAKE AIR TEMPERATURE SENSOR
 - ★ 4 THROTTLE POSITION SENSOR
 - ★ 5 CAMSHAFT POSITION SENSOR
 - ★ 6 CRANKSHAFT POSITION SENSOR
 - ★ 7 BAROMETRIC PRESSURE SENSOR
 - ★ 8 ENGINE COOLANT TEMPERATURE SENSOR
 - ★ 9 KNOCK SENSOR
 - ★ 10 HEATED OXYGEN SENSOR (REAR)
 - ★ 11 MANIFOLD DIFFERENTIAL PRESSURE SENSOR
 - ★ 12 FUEL TANK DIFFERENTIAL PRESSURE SENSOR
 - ★ 13 FUEL TEMPERATURE SENSOR
 - ★ 14 FUEL LEVEL SENSOR
-
- POWER SUPPLY
 - VEHICLE SPEED SENSOR <M/T>
 - OUTPUT SHAFT SPEED SENSOR <A/T>
 - A/C SWITCH
 - PARK/NEUTRAL POSITION SWITCH <A/T>
 - POWER STEERING PRESSURE SWITCH
 - IGNITION SWITCH - ST

DECIDE

ECM <M/T>
PCM <A/T>

ACT

- ◆ 1 INJECTOR
 - ◆ 2 EVAPORATIVE EMISSION PURGE SOLENOID
 - ◆ 3 IDLE AIR CONTROL MOTOR
 - ◆ 4 EGR SOLENOID
 - ◆ 5 EVAPORATIVE EMISSION VENTILATION SOLENOID
-
- FUEL PUMP RELAY 1, 2
 - MULTIPOINT FUEL INJECTION (MFI) RELAY
 - A/C COMPRESSOR CLUTCH RELAY
 - MALFUNCTION INDICATOR LAMP (SERVICE ENGINE SOON)
 - DIAGNOSTIC OUTPUT
 - IGNITION COIL, IGNITION POWER TRANSISTER

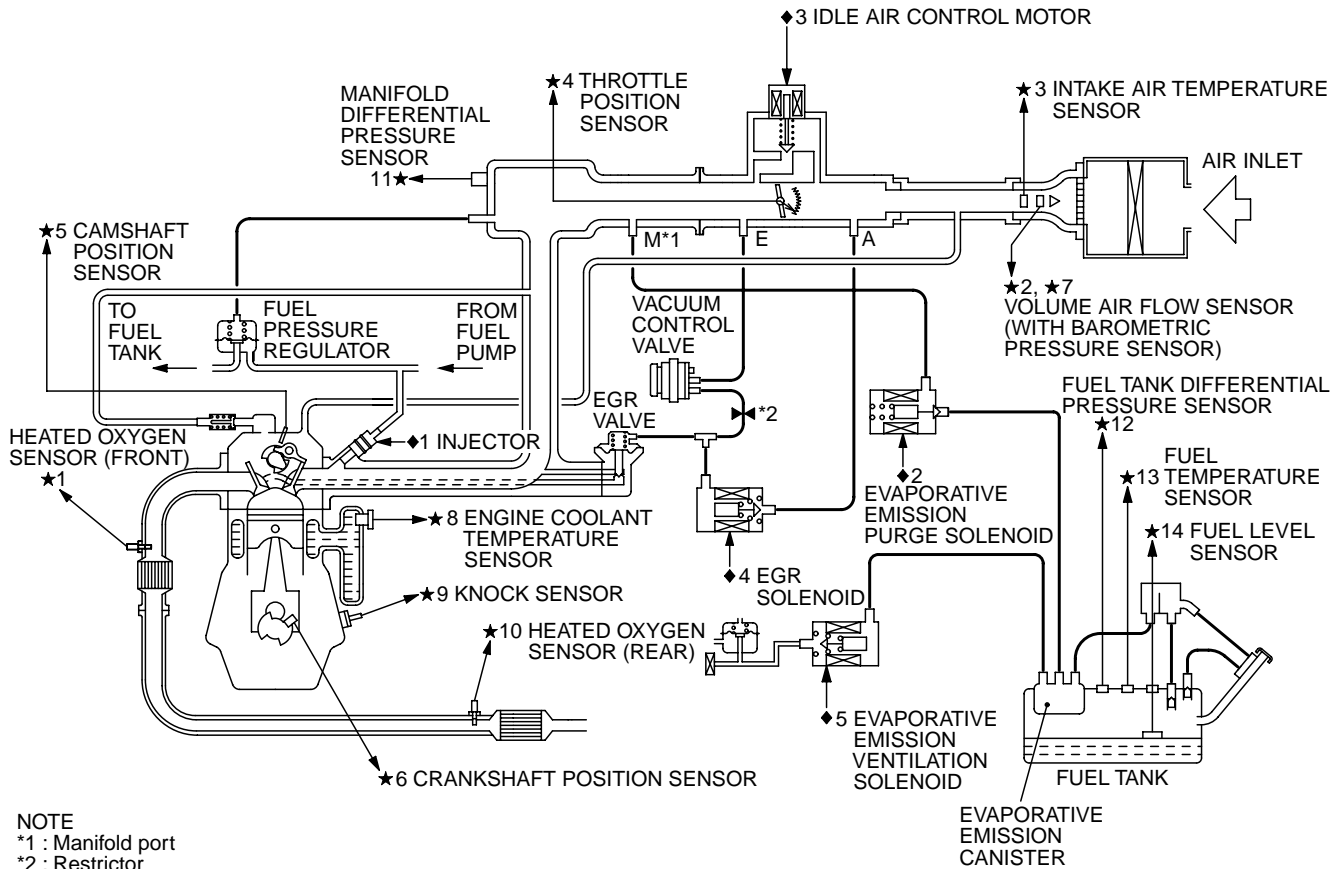





AK200981

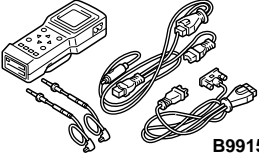

NOTE: For the vacuum hose routing, refer to GROUP 17, Vacuum Hoses P.17-108.

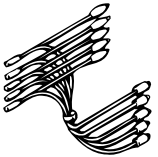
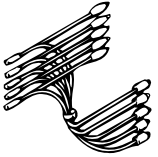
SPECIAL TOOLS

M1131000600148

TOOL	TOOL NUMBER AND NAME	SUPERSESSON	APPLICATION
 <p>B991502</p>	<p>MB991502 Scan tool <MUT-II></p>	<p>MB991496-OD</p>	<ul style="list-style-type: none"> • Reading diagnostic trouble code • MFI system inspection
 <p>MB991348</p>	<p>MB991348 Test harness set</p>	<p>MB991348-01</p>	<ul style="list-style-type: none"> • Inspection using an oscilloscope
	<p>MB991709 Test harness set</p>	<p>MB991709-01</p>	<ul style="list-style-type: none"> • Inspection using an oscilloscope • Inspection of idle air control motor • Adjustment of throttle position sensor
 <p>MB991658</p>	<p>MB991223 Test harness set A: MB991219 Inspection harness B: MB991220 LED harness C: MB991221 LED harness adaptor D: MB991222 Probe</p>	<p>MB991223</p>	<ul style="list-style-type: none"> • A: Inspection of heated oxygen sensor (rear) • A: Inspection using an oscilloscope
 <p>MB991658</p>	<p>MB991658 Test harness SET</p>	<p>Tool not available</p>	<ul style="list-style-type: none"> • Inspection using an oscilloscope
	<p>MD998464 Test harness (4 pin, square)</p>	<p>MD998464-01</p>	<ul style="list-style-type: none"> • Inspection of heated oxygen sensor (front) • Inspection using an oscilloscope

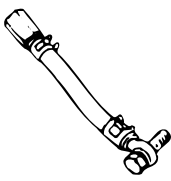
cardiagn.com

TOOL	TOOL NUMBER AND NAME	SUPERSESSION	APPLICATION
	MD998709 Adaptor hose	MIT210196	Measurement of fuel pressure
	MD998742 Hose adaptor	MD998742-01	
 MB991637	MB991637 Fuel pressure gauge set	Tool not available	

ON-VEHICLE SERVICE

COMPONENT LOCATION

M1131002100387

NAME	SYMBOL	NAME	SYMBOL
Air conditioning compressor clutch relay	K	Heated oxygen sensor (front)	M
Camshaft position sensor	Q	Heated oxygen sensor (rear)	V
Crankshaft position sensor	A	Idle air control motor	G
Data link connector	T	Ignition coil	B
EGR solenoid	D	Injector	C
Engine control module (ECM) <M/T>	U	Knock sensor	N
Engine coolant temperature sensor	P	Manifold differential pressure sensor	E
Engine speed detection connector	J	Multiport fuel injection (MFI) relay	K
Evaporative emission purge solenoid	D	Park/neutral position switch <A/T>	I
Evaporative emission ventilation solenoid	Y	Powertrain control module (PCM) <A/T>	U
Fan controller	O	Power steering pressure switch	L
Fuel tank differential pressure sensor	W	Throttle position sensor	F
Fuel temperature sensor	X	Vehicle speed sensor <M/T>	R
Fuel pump relay 1, 2	S	Volume air flow sensor (with built-in intake air temperature sensor and barometric pressure sensor)	H

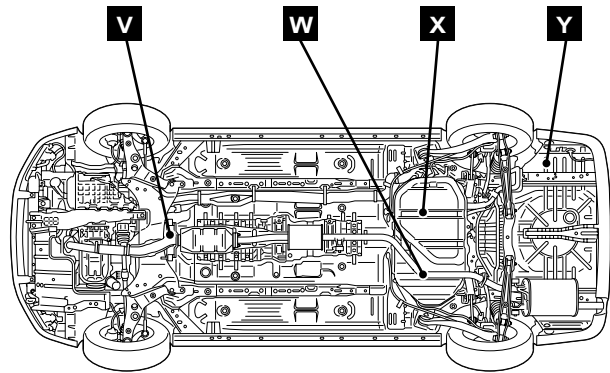
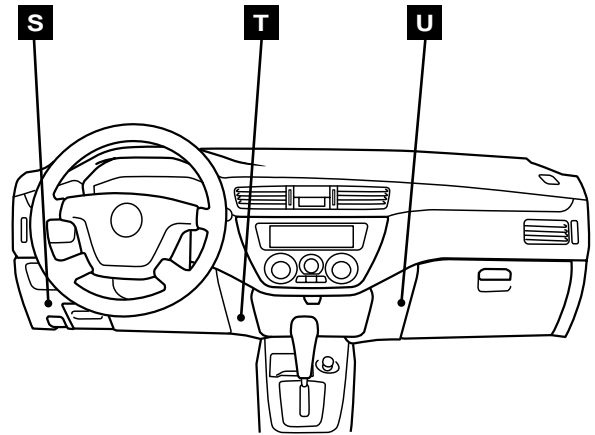
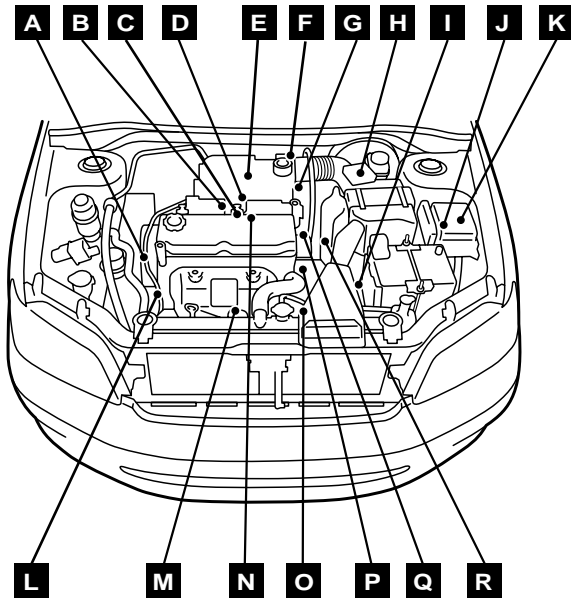

AK101267AB

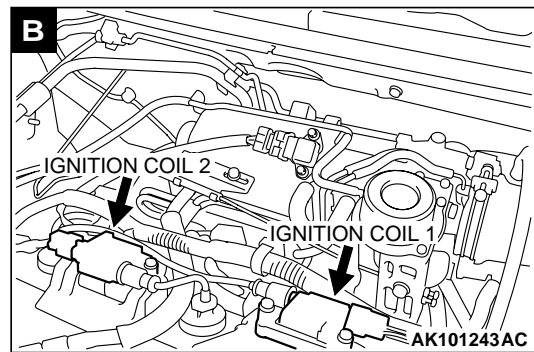
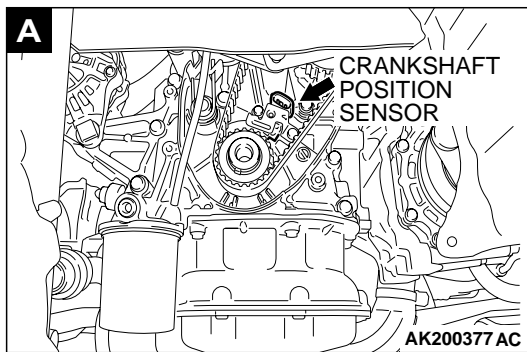

cardiagn.com

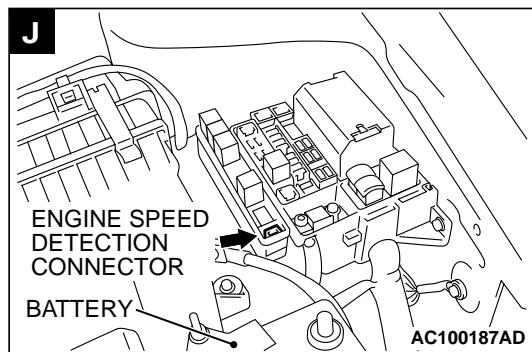
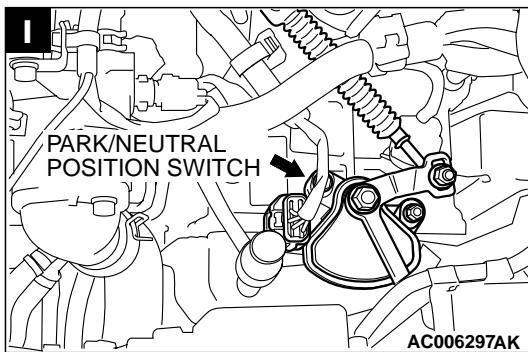
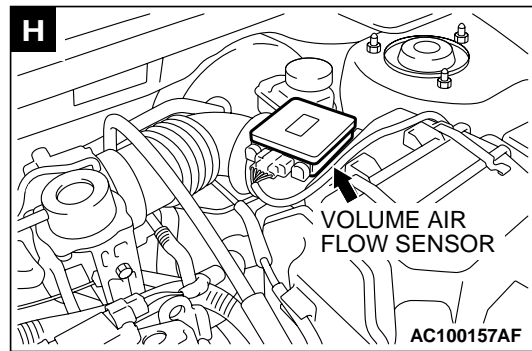
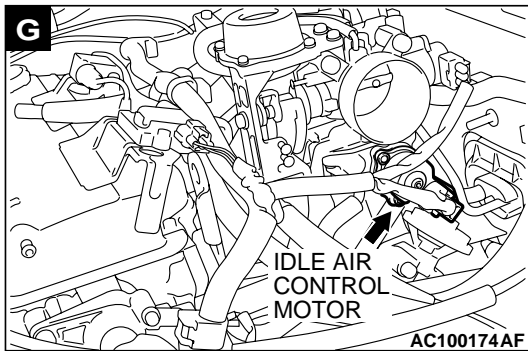
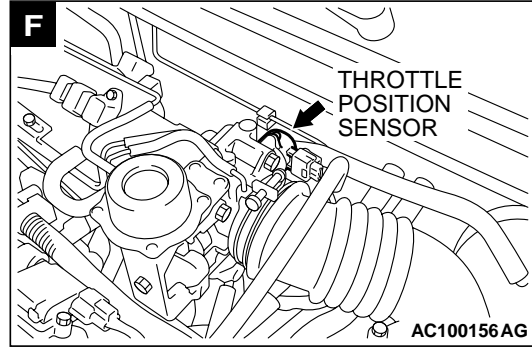
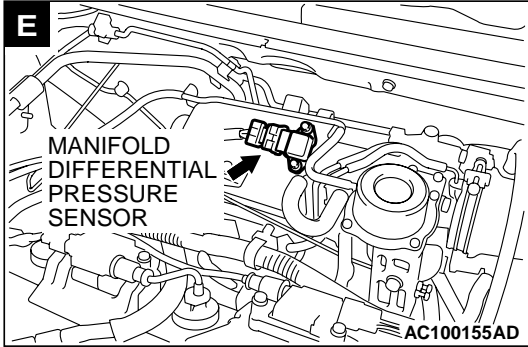
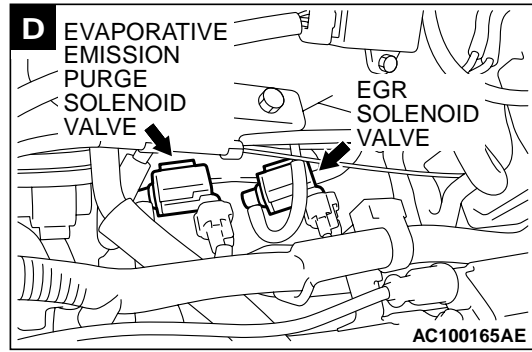
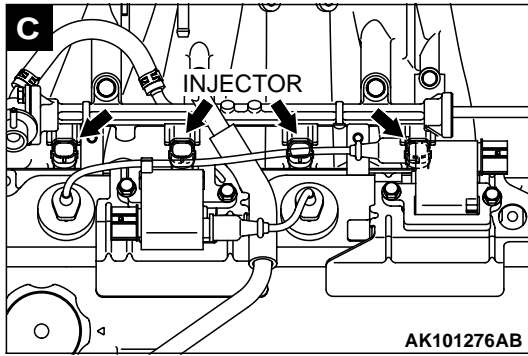

cardiagn.com

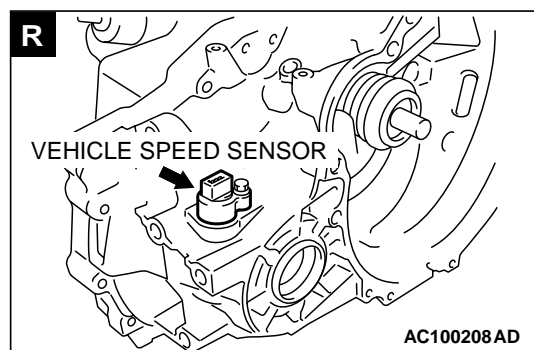
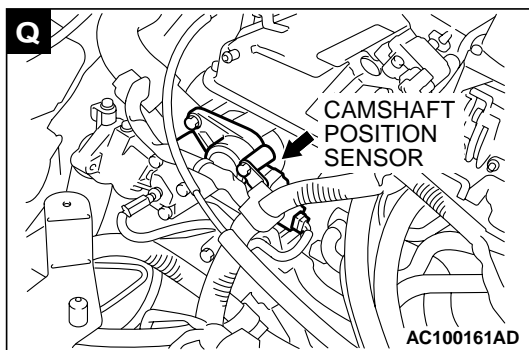
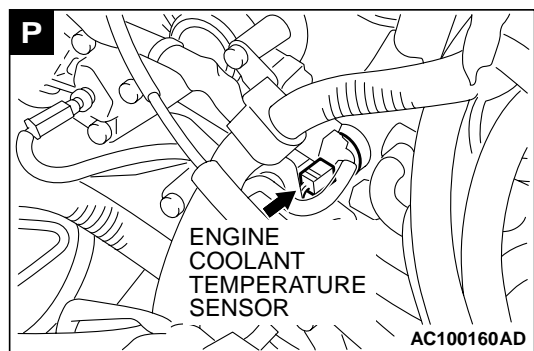
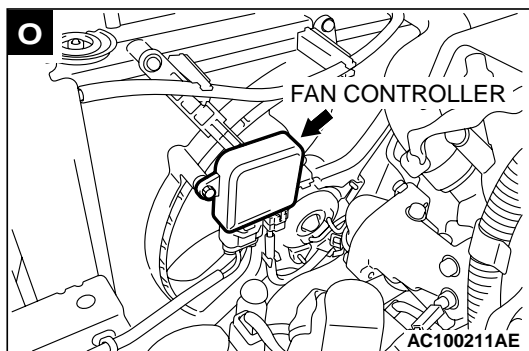
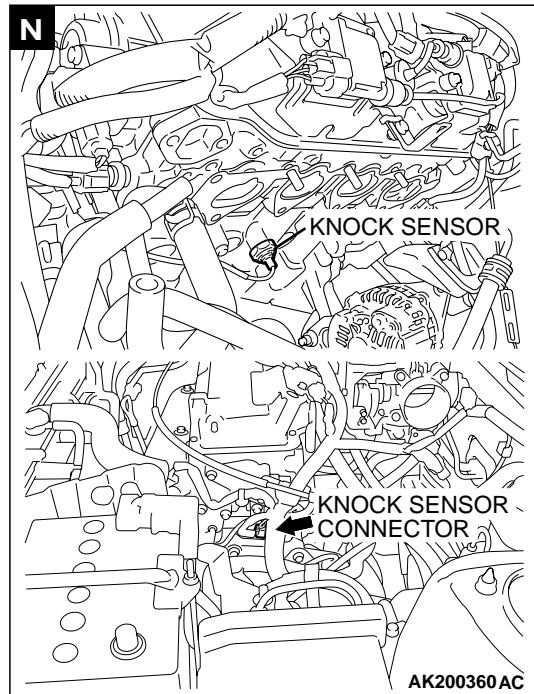
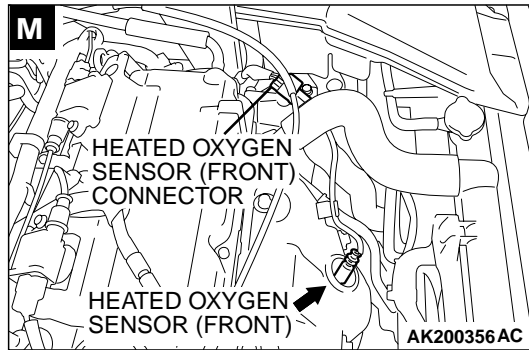
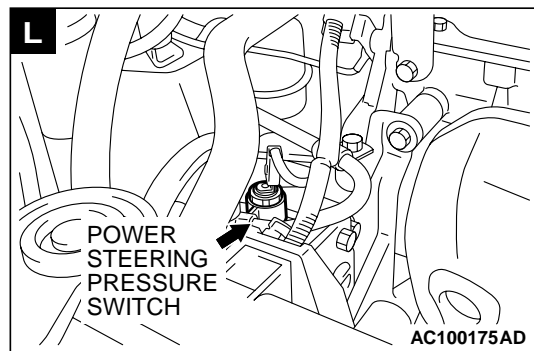
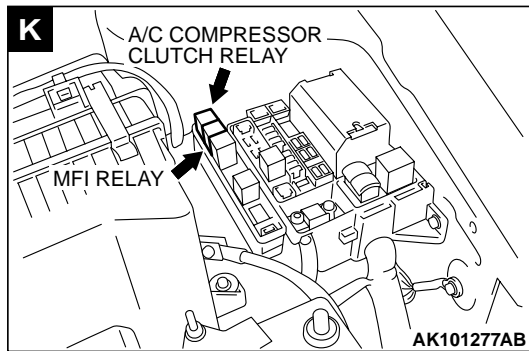

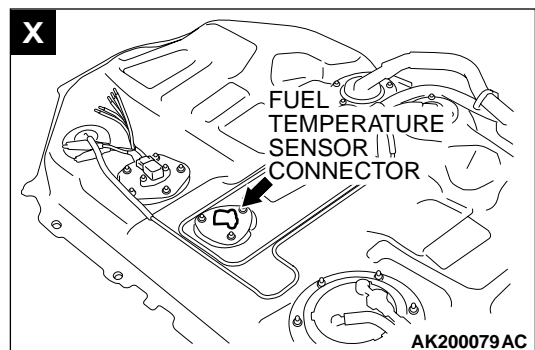
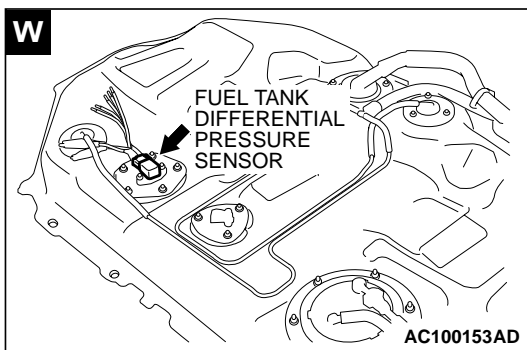
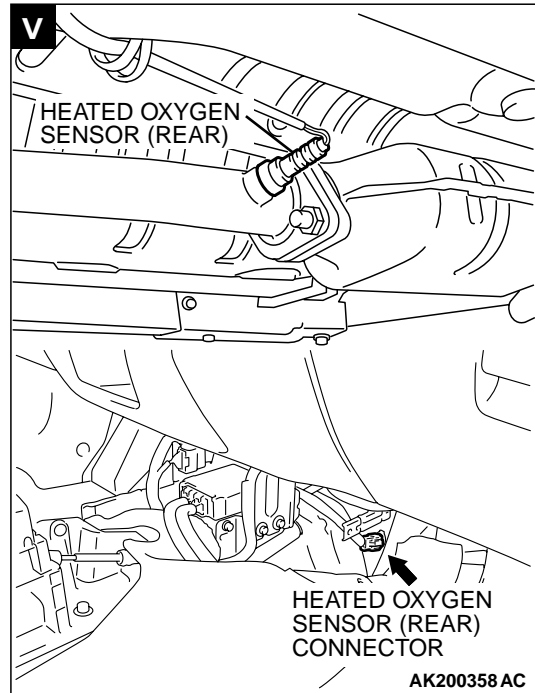
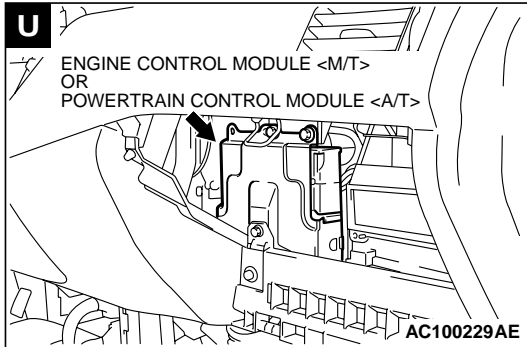
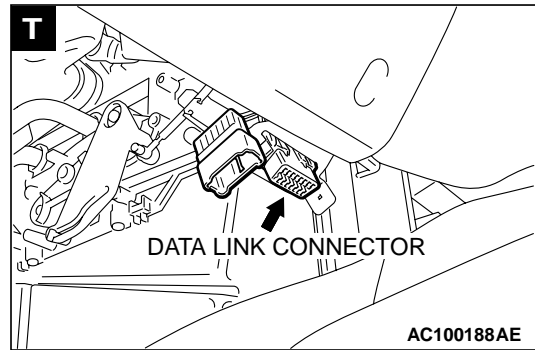
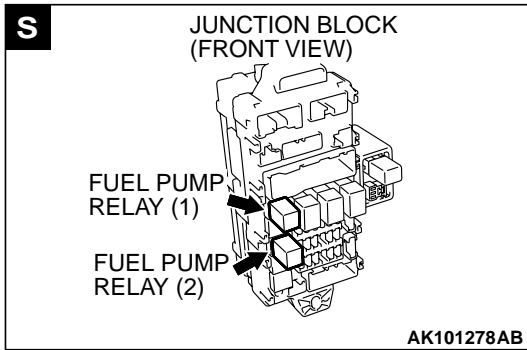

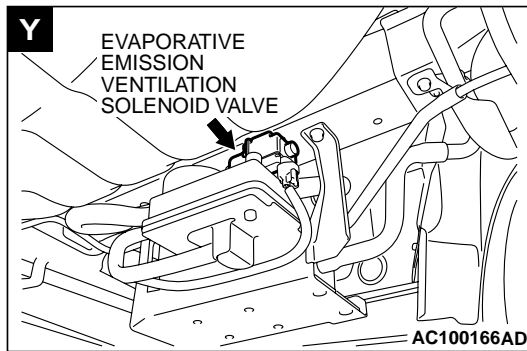

THROTTLE BODY CLEANING

M1131001000127

Required Special Tool:

- MB991502: Scan Tool (MUT-II)

1. Start the engine and warm it up until the coolant is heated to 80°C (176°F) or higher. Then stop the engine.
2. Remove the air intake hose from the throttle body.

CAUTION

Do not allow cleaning solvent to enter the bypass passage.

3. Plug the bypass passage inlet (arrow) of the throttle body.
4. Spray cleaning solvent into the valve through the throttle body intake port and leave it for approximately five minutes.
5. Start the engine, rev it several times and then idle it for about one minute. If the idling speed becomes unstable (or if the engine stalls) due to the bypass passage being plugged, slightly open the throttle valve to keep the engine running.
6. If the throttle valve deposits are not removed, repeat steps 4 and 5.
7. Unplug the bypass passage inlet.
8. Attach the air intake hose.

CAUTION

To prevent damage to scan tool MB991502, always turn the ignition switch to the "LOCK" (OFF) position before connecting or disconnecting the scan tool MB991502.

9. Use the scan tool to erase any diagnostic trouble code.
10. Adjust the basic idle speed. (Refer to P.13Aa-13.)

WARNING

Battery posts, terminals and related accessories contain lead and lead compounds. WASH HANDS AFTER HANDLING.

NOTE: If the engine hunts while idling after adjustment of the basic idle speed, disconnect the negative cable from the battery for 10 seconds or more, and then reconnect it and run the engine at idle for about 10 minutes after the engine is warmed up.

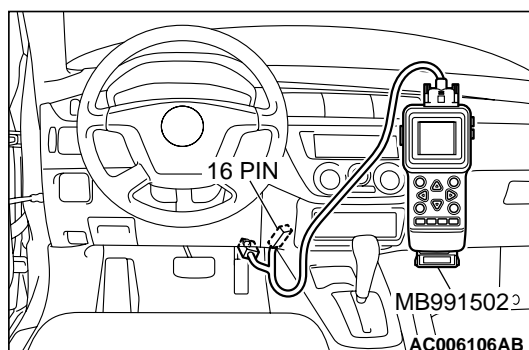
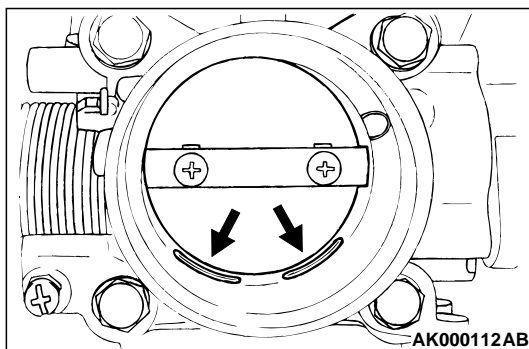

THROTTLE POSITION SENSOR ADJUSTMENT

M1131001100287

Required Special Tools:

- MB991502: Scan Tool (MUT-II)
- MB991709: Test Harness Set

CAUTION

To prevent damage to scan tool MB991502, always turn the ignition switch to the "LOCK" (OFF) position before connecting or disconnecting the scan tool MB991502.

1. Connect scan tool MB991502 to the data link connector. When not using scan tool follow the steps below.

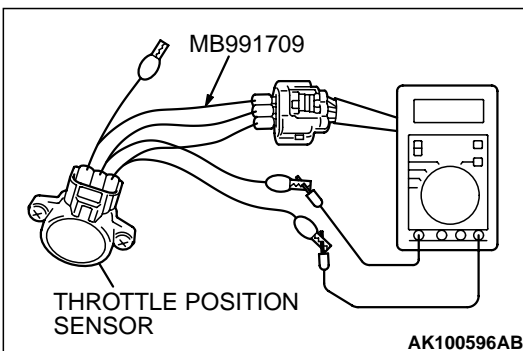
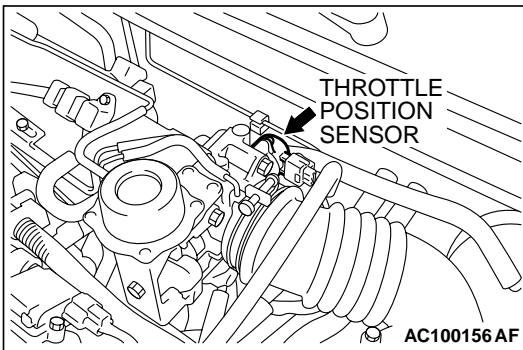
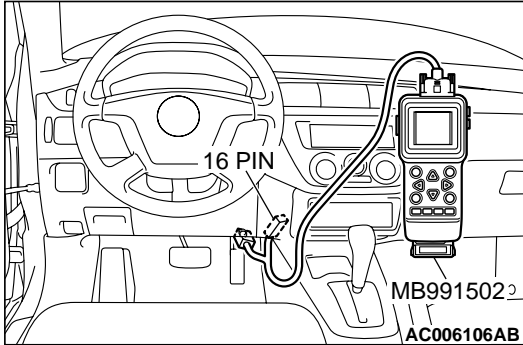

- (1) Disconnect the throttle position sensor connector, and connect the special tool MB991709 in between. (All terminals should be connected.)

- (2) Connect a digital voltmeter between throttle position sensor terminal 1 (sensor output) and terminal 2 (sensor ground).

2. Turn the ignition switch to the "ON" position (but do not start the engine).

3. Check the throttle position sensor output voltage.

Standard value: 335 – 935 mV

4. If not within the standard value range, adjust by loosening throttle position sensor mounting bolts and turning the throttle position sensor body. After adjusting, tighten the bolts securely.
5. Turn the ignition switch to the "LOCK" (OFF) position.
6. Disconnect scan tool MB991502. When the scan tool is not used, remove special tool MB991709, and connect the throttle position sensor connector.

FIXED SAS ADJUSTMENT

M1131001500047

CAUTION

The fixed SAS should not be moved unnecessarily; it has been precisely adjusted by the manufacturer. If the adjustment is disturbed for any reason, readjust as follows.

1. Loosen the tension of the accelerator cable sufficiently.

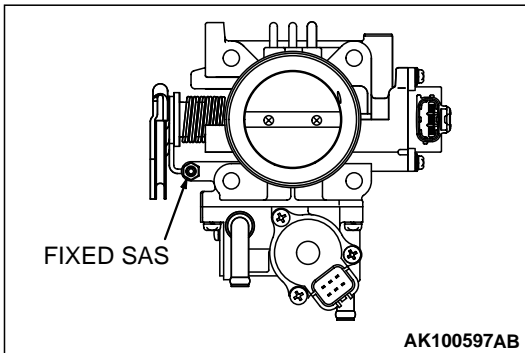

2. Back out the fixed SAS lock nut.
3. Turn the fixed SAS counterclockwise until it is sufficiently backed out, and fully close the throttle valve.
4. Turn the fixed SAS clockwise until the throttle lever is touched (i.e., the point at which the throttle valve begins to open).
From that point, turn the fixed SAS clockwise another 1-1/4 turn.
5. While holding the fixed SAS so that it doesn't move, tighten the lock nut securely.
6. Adjust the tension of the accelerator cable.
7. Adjust the basic idle speed. (Refer to P.13Aa-13.)
8. Adjust the throttle position sensor. (Refer to P.13Aa-12.)

BASIC IDLE SPEED ADJUSTMENT

M1131001800253

Required Special Tool:

- MB991502: Scan Tool (MUT-II)

NOTE: The standard idle speed has been adjusted with the speed adjusting screw (SAS), by the manufacturer, and there should be no need for readjustment.

NOTE: If the adjustment has been changed by mistake, the idle speed may become too high or the idle speed may drop too low when loads A/C, defogger, etc. are placed on the engine. If this occurs, adjust by the following procedure.

NOTE: The adjustment, if made, should be made after first confirming that the spark plugs, the injectors, the idle air control motor, compression, etc., are all normal.

1. The vehicle should be prepared as follows before the inspection and adjustment.
 - Engine coolant temperature: 80 – 95°C (176 – 203°F)
 - Lights, electric cooling fan and accessories: OFF
 - Transaxle: Neutral (A/T for "P" range)

⚠ CAUTION

To prevent damage to scan tool MB991502, always turn the ignition switch to the "LOCK" (OFF) position before connecting or disconnecting scan tool MB991502.

2. Connect scan tool MB991502 to the data link connector (16-pin).
3. Start the engine and run at idle.
4. Select the item number 30 of the scan tool Actuator test.
NOTE: Use the scan tool to hold the IAC motor at the basic step to adjust the basic idle speed.
5. Check the idle speed.

Standard value: 700 ± 50 r/min

NOTE: The engine speed may be 20 to 100 r/min lower than indicated above for a new vehicle [driven approximately 500 km (300 mile) or less], but no adjustment is necessary.

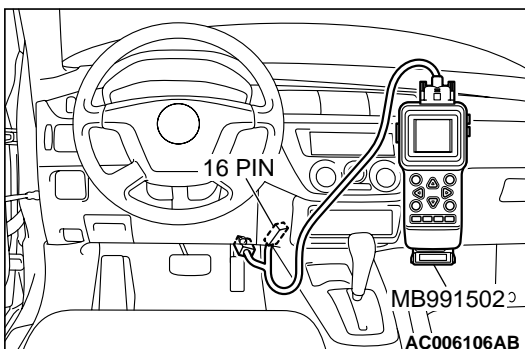

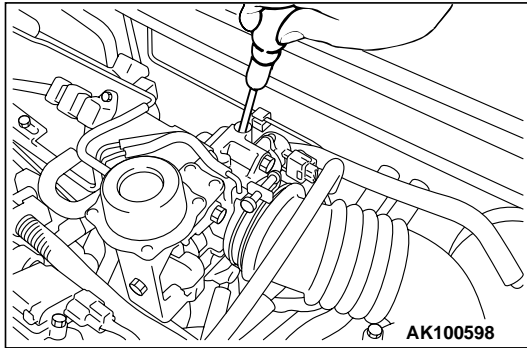

NOTE: If the engine stalls or the engine speed is low even though the vehicle has been driven approximately 500 km (300 mile) or more, it is probable that deposits are adhered to the throttle valve, so clean it. (Refer to P.13Aa-11.)

- If not within the standard value range, turn the speed adjusting screw (SAS) to make the necessary adjustment.

NOTE: If the idling speed is higher than the standard value range even when the SAS is fully closed, check whether or not there is any indication that the fixed SAS has been moved. If there is an indication that it has been moved, adjust the fixed SAS. (Refer to P.13Aa-12.)

- Press the scan tool clear key, and release the IAC motor Actuator test mode.

NOTE: Unless the IAC motor is released, the Actuator test mode will continue for 27 minutes.

- Turn the ignition switch to the "LOCK" (OFF) position.
- Disconnect scan tool MB991502.
- Start the engine again and let it idle for about 10 minutes. Check that the idling condition is normal.

FUEL PRESSURE TEST

M1131001900119

Required Special Tools:

- MB991502: Scan Tool (MUT-II)
- MB991637: Fuel Pressure Gauge Set
- MD998709: Adaptor Hose
- MD998742: Hose Adaptor

- Release residual pressure from the fuel line to prevent fuel spray. (Refer to P.13Aa-17.)

⚠ WARNING

To prevent a fire, cover the hose connection with shop towels to prevent splashing of fuel that could be caused by some residual pressure in the fuel pipe line.

- Disconnect the high-pressure fuel hose at the fuel rail side.
- Assemble the fuel pressure measurement tools as follows.

<When using the fuel pressure gauge>

- Remove the union joint and bolt from special tool MD998709 (adaptor hose) and instead attach special tool MD998742 (hose adaptor) to the adaptor hose.
- Place a suitable O-ring or gasket on assembled special tools MD998709 and MD998742 and install the fuel pressure gauge.
- Install the assembled fuel pressure measurement tools between the fuel rail and high-pressure fuel hose.

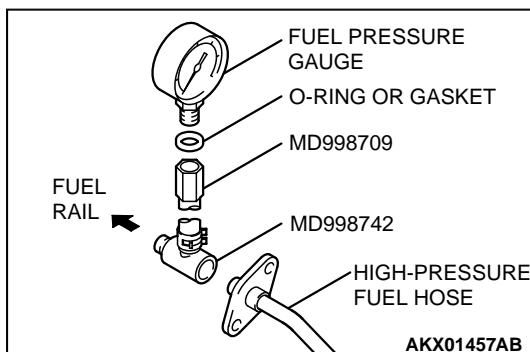

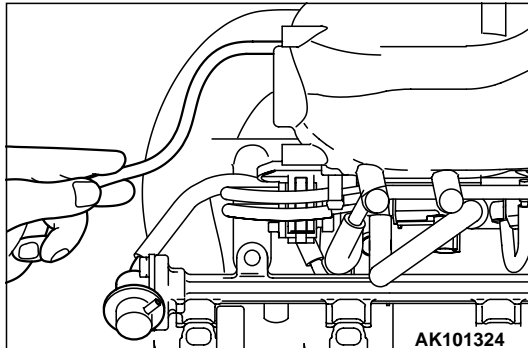
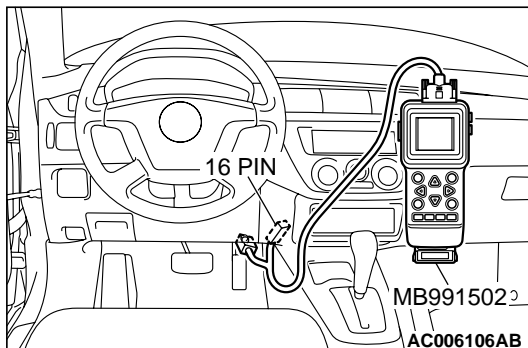
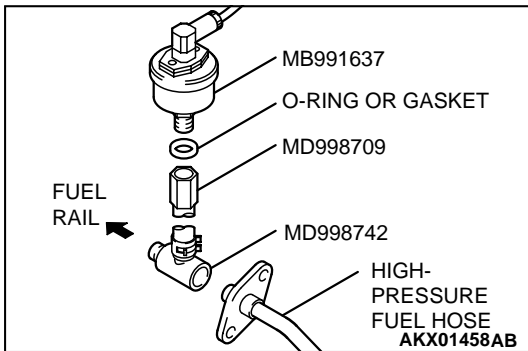

<When using the special tool MB991637 (fuel pressure gauge set)>

1. Remove the union joint and bolt from special tool MD998709 (adaptor hose) and instead attach special tool MD998742 (hose adaptor) to the adaptor hose.
2. Install special tool MB991637 (fuel pressure gauge set) to assembled special tools MD998709 and MD998742 via a gasket.
3. Install the assembled fuel pressure measurement tools between the fuel rail and the high-pressure fuel hose.

CAUTION

To prevent damage to scan tool MB991502, always turn the ignition switch to the "LOCK" (OFF) position before connecting or disconnecting scan tool MB991502.

4. Connect scan tool MB991502 to the data link connector.
5. Use the Actuator test 07 to drive the fuel pump. Check that there is no fuel leaking from any section when the fuel pump is operating.
6. Stop the fuel pump.
7. Start the engine and run at idle.
8. Measure fuel pressure while the engine is running at idle.

Standard value: Approximately 270 kPa (38 psi) at curb idle

9. Disconnect the vacuum hose from the fuel pressure regulator and measure fuel pressure with the hose end closed with your finger.
10. Check to see that fuel pressure at idle does not drop even after the engine has been revved several times.
11. Revving the engine repeatedly, hold the fuel return hose lightly with your fingers to feel that fuel pressure is present in the return hose.

NOTE: If the fuel flow rate is low, there will be no fuel pressure in the return hose.

12. If any of fuel pressure measured in steps 10 to 13 is out of specification, troubleshoot and repair according to the table below.

SYMPTOM	PROBABLE CAUSE	REMEDY
<ul style="list-style-type: none"> • Fuel pressure too low • Fuel pressure drops after racing • No fuel pressure in fuel return hose 	Clogged fuel filter	Replace fuel filter
	Fuel leaking to return side due to poor fuel regulator valve seating or settled spring	Replace fuel pressure regulator
	Low fuel pump delivery pressure	Replace fuel pump

SYMPTOM	PROBABLE CAUSE	REMEDY
Fuel pressure too high	Binding valve in fuel pressure regulator	Replace fuel pressure regulator
	Clogged fuel return hose or pipe	Clean or replace hose or pipe
Same fuel pressure when vacuum hose is connected and when disconnected	Damaged vacuum hose or clogged nipple	Replace vacuum hose or clean nipple
	Defective fuel pressure regulator	Replace fuel pressure regulator

13. Stop the engine and observe fuel pressure gauge reading. It is normal if the reading does not drop within two minutes. If it does, observe the rate of drop and troubleshoot and repair according to the table below. Start, then stop the engine.

- (1) Squeeze the fuel return line closed to confirm leak-down occurs from defective fuel pressure regulator.
- (2) Squeeze the fuel supply line closed to confirm leak-down occurs from defective fuel pump check valve.
- (3) If pressure continues to drop with both fuel lines squeezed closed, injector(s) are leaking.

SYMPTOM	PROBABLE CAUSE	REMEDY
Fuel pressure drops gradually after engine is stopped	Leaky injector	Replace injector
	Leaky fuel regulator valve seat	Replace fuel pressure regulator
Fuel pressure drops sharply immediately after engine is stopped	Check valve in fuel pump is held open	Replace fuel pump

14. Release residual pressure from the fuel pipe line. (Refer to P.13Aa-17.)

⚠ WARNING

Cover the hose connection with shop towels to prevent splash of fuel that could be caused by some residual pressure in the fuel pipe line.

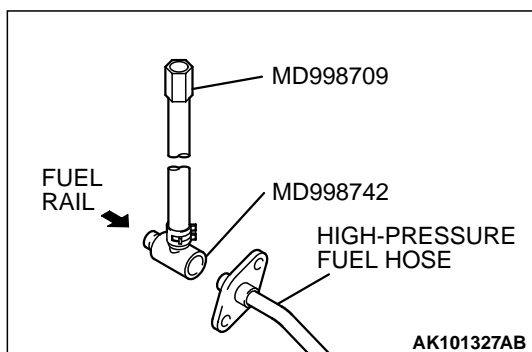

15. Remove the fuel pressure gauge or special tool MB991637, and special tools MD998709 and MD998742 from the fuel rail.

16. Replace the O-ring at the end of the high-pressure fuel hose with a new one.

17. Fit the high-pressure fuel hose into the fuel rail and tighten the bolts to specified torque.

Tightening torque: 4.9 ± 1.0 (44 ± 8 in-lb)

18. Check for fuel leaks.

- (1) Use scan tool MB991502 to operate the fuel pump.
- (2) Check the fuel line for leaks, and repair as needed.

19. Disconnect scan tool MB991502.

FUEL PUMP CONNECTOR DISCONNECTION (HOW TO REDUCE PRESSURIZED FUEL LINES)

M1131000900440

⚠ WARNING

When removing the fuel pipe, etc., release fuel pressure to prevent fuel spray.

1. Remove the rear seat assembly (Refer to GROUP 52A P.52A-18.)
2. Remove the protector.
3. Disconnect the fuel pump module connector.
4. After starting the engine and letting it run until it stops naturally, turn the ignition switch to the "LOCK" (OFF) position.
5. Connect the fuel pump module connector.
6. Install the protector and rear seat assembly (Refer to GROUP 52A P.52A-18.)

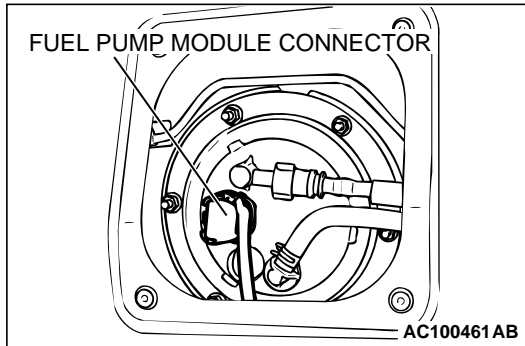

FUEL PUMP OPERATION CHECK

M1131002000465

Required Special Tool:

- MB991502: Scan Tool (MUT-II)

⚠ CAUTION

To prevent damage to scan tool MB991502, always turn the ignition switch to the "LOCK" (OFF) position before connecting or disconnecting scan tool MB991502.

1. Check the operating of the fuel pump by using scan tool MB991502 to force-drive the fuel pump.

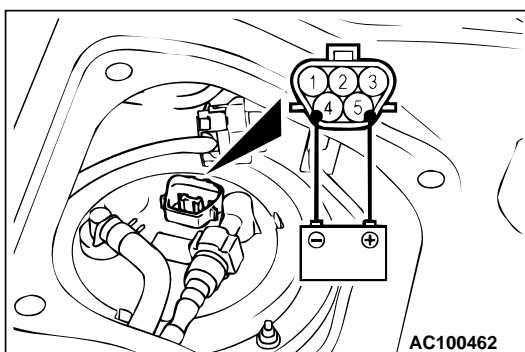
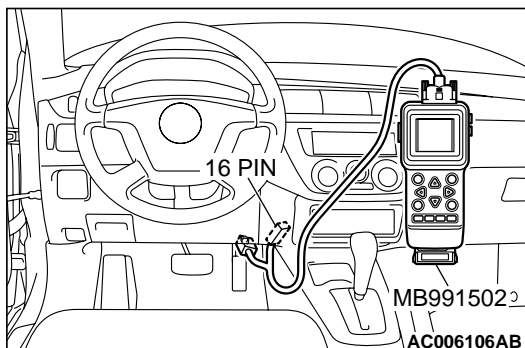

2. If the fuel pump will not operate, check by using the following procedure. If normal, check the fuel pump drive circuit.
 - (1) Turn the ignition switch to the "LOCK" (OFF) position.
 - (2) Remove the rear seat assembly (Refer to GROUP 52A P.52A-18.)
 - (3) Remove the protector.
 - (4) Disconnect the fuel pump module connector.
 - (5) When the fuel pump drive connector is attached directly to the battery, check if the sound of the fuel pump operation can be heard.

NOTE: As the fuel pump is an in-tank type, the fuel pump sound is hard to hear. Remove the fuel tank filler tube cap and check from the tank inlet.

- (6) Check for fuel pressure by pinching the fuel hose with fingertips.
- (7) Connect the fuel pump module connector.

(8) Install the protector and rear seat assembly (Refer to GROUP 52A P.52A-18.)

MULTIPOINT FUEL INJECTION (MFI) RELAY CONTINUITY CHECK

M113105000011

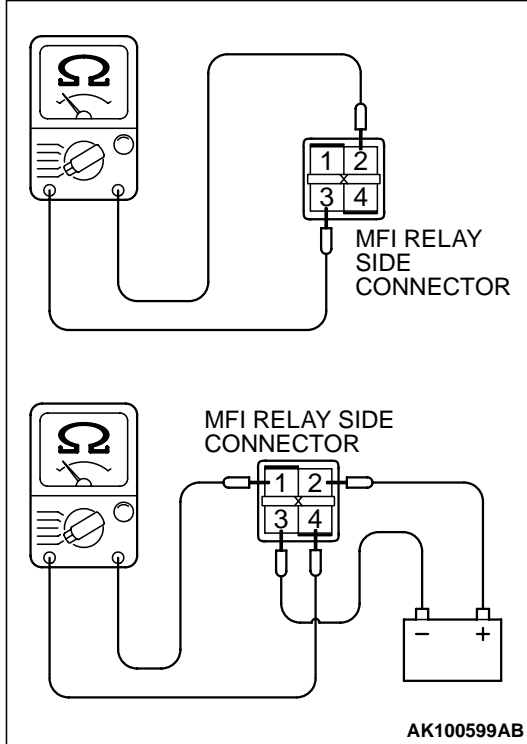

BATTERY VOLTAGE	TERMINAL NO. TO BE CONNECTED TO BATTERY	TERMINAL NO. TO BE CONDUCTED
Not supplied	-	2 - 3
Supplied	2 - 3	1 - 4

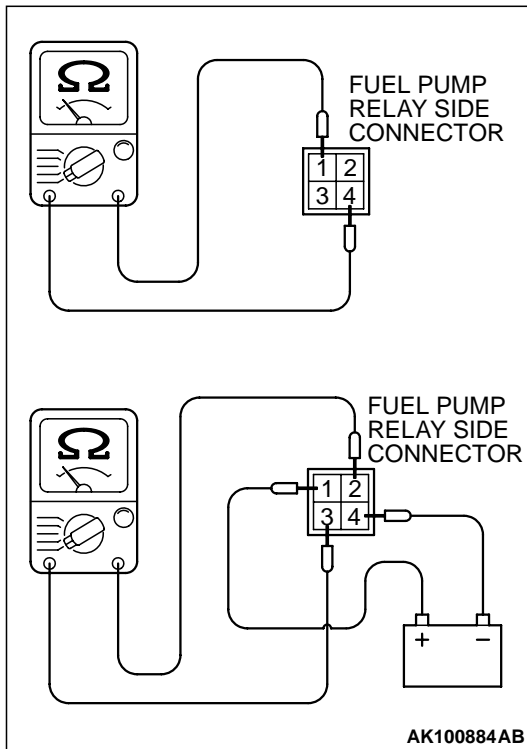

FUEL PUMP RELAY CONTINUITY CHECK

M113103300018

BATTERY VOLTAGE	TERMINAL NO. TO BE CONNECTED TO BATTERY	TERMINAL NO. TO BE CONDUCTED
Not supplied	-	1 - 4
Supplied	1 - 4	2 - 3

cardiagn.com

INTAKE AIR TEMPERATURE SENSOR CHECK

M1131002800148

1. Disconnect the volume air flow sensor connectors.
2. Measure resistance between terminals 5 and 6.

Standard value:

- 13 – 17 kΩ [at -20°C (-4°F)]
- 5.3 – 6.7 kΩ [at 0°C (32°F)]
- 2.3 – 3.0 kΩ [at 20°C (68°F)]
- 1.0 – 1.5 kΩ [at 40°C (104°F)]
- 0.56 – 0.76 kΩ [at 60°C (140°F)]
- 0.30 – 0.42 kΩ [at 80°C (176°F)]

3. If not within specifications, replace the volume air flow sensor.

4. Measure resistance while heating the sensor using a hair dryer.

Normal condition:

TEMPERATURE	RESISTANCE (kΩ)
Higher	Smaller

5. If resistance does not decrease as heat increases, replace the volume air flow sensor assembly.

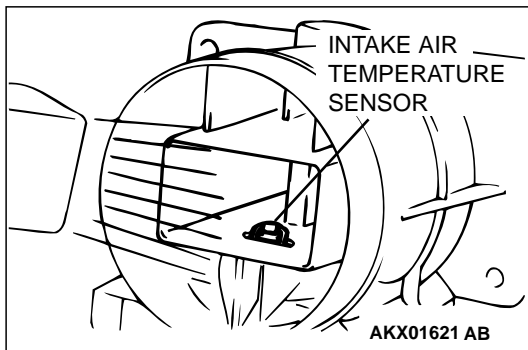
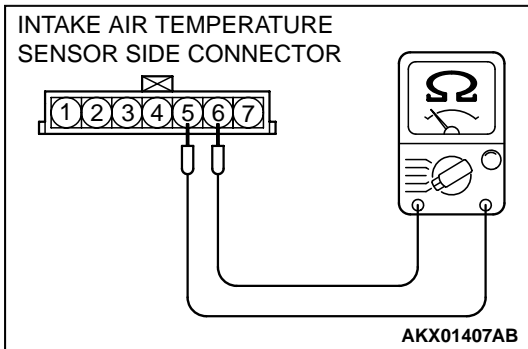

ENGINE COOLANT TEMPERATURE SENSOR CHECK

M1131003100142

CAUTION

Be careful not to touch the connector (resin section) with the tool when removing and installing.

1. Drain engine coolant, then remove the engine coolant temperature sensor.
2. With the temperature sensing portion of engine coolant temperature sensor immersed in hot water, check the resistance.

Standard value:

- 14 – 17 kΩ [at -20°C (-4°F)]
- 5.1 – 6.5 kΩ [at 0°C (32°F)]
- 2.1 – 2.7 kΩ [at 20°C (68°F)]
- 0.9 – 1.3 kΩ [at 40°C (104°F)]
- 0.48 – 0.68 kΩ [at 60°C (140°F)]
- 0.26 – 0.36 kΩ [at 80°C (176°F)]

3. If resistance deviates from the standard value greatly, replace the sensor.

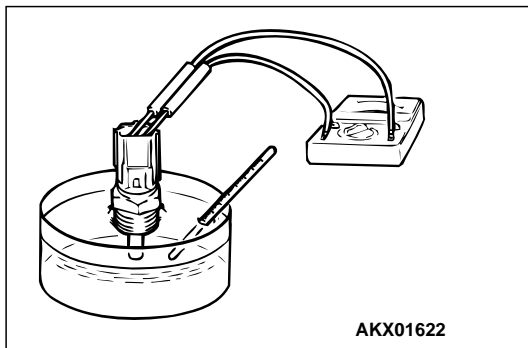

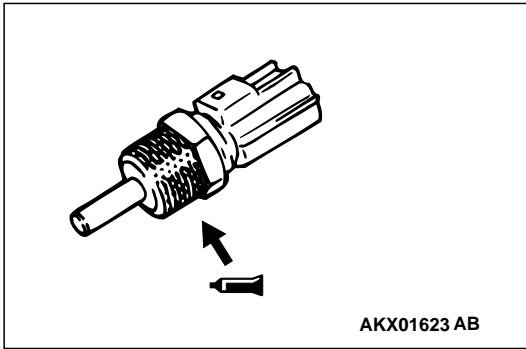

4. Apply 3M™ AAD part number 8731 or equivalent to threaded portion.
5. Install the engine coolant temperature sensor and tighten it to the specified torque.

Tightening torque: 29 ± 10 N·m (22 ± 7 ft-lb)

THROTTLE POSITION SENSOR CHECK

M1131003200138

Required Special Tool:

- MB991709: Test Harness Set

Checking the Terminal Resistance

1. Disconnect the throttle position sensor connector.
2. Measure resistance between the throttle position sensor side connector terminal 2 and terminal 3.

Standard value: 2.0 – 4.0 kΩ

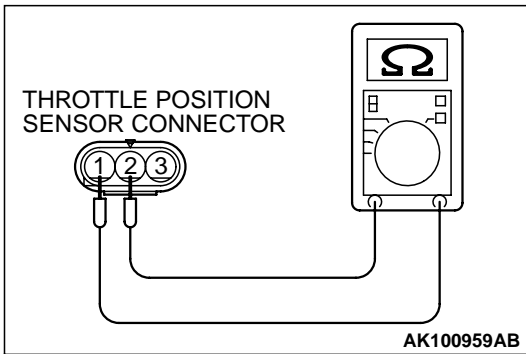
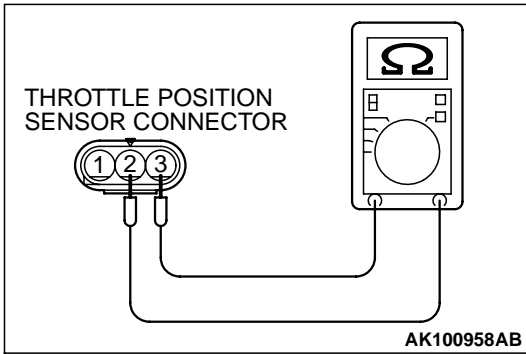

3. Measure resistance between the throttle position sensor side connector terminal 1 and terminal 2.

Normal condition:

Throttle valve slowly open until fully open from the idle position	Changes smoothly in proportion to the opening angle of the throttle valve
--	---

4. If resistance is outside the standard value, or if it doesn't change smoothly, replace the throttle position sensor.

NOTE: After replacement, the throttle position sensor should be adjusted. (Refer to P.13Aa-12.)

Check using oscilloscope

1. Disconnect the throttle position sensor connector and connect the test harness special tool (MB991709) in between.(All terminals should be connected.)

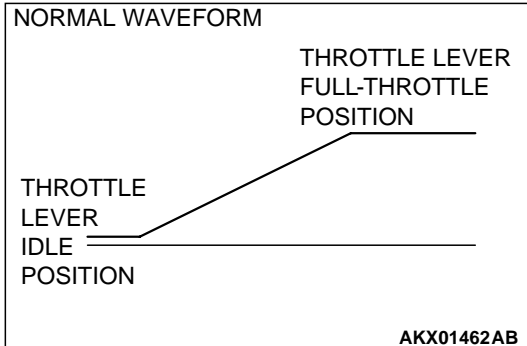
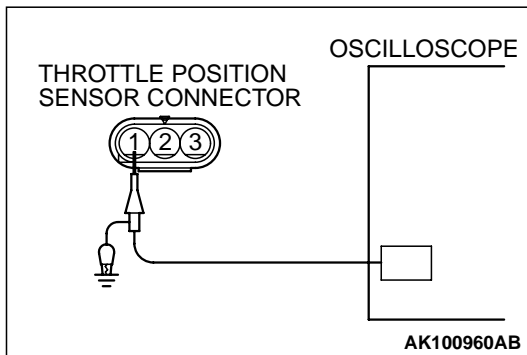

2. Connect the oscilloscope probe to the throttle position sensor side connector terminal 1.
3. Turn the ignition switch "ON" position.

4. Slowly move the throttle lever from the idle position to the full-throttle position and check then if the waveform is free from any noise.
5. If any noise is recognized, replace the throttle position sensor.

NOTE: After replacement, the throttle position sensor should be adjusted. (Refer to P.13Aa-12.)

HEATED OXYGEN SENSOR CHECK

M1131005000152

Required Special Tools:

- MB991658: Test Harness Set
- MD998464: Test Harness

<Heated oxygen sensor (front)>

1. Using the scan tool MB991502, observe HO₂S reading. If values are unsatisfactory, or if Scan tool is not available, use the following procedure:
 - (1) Disconnect the heated oxygen sensor connector and connect special tool MD998464 to the connector on the heated oxygen sensor side.
 - (2) Make sure that there is continuity [4.5 – 8.0 Ω at 20°C (68°F)] between terminal 1 (red clip of special tool) and terminal 3 (blue clip of special tool) on the heated oxygen sensor connector
 - (3) If there is no continuity, replace the heated oxygen sensor.
 - (4) Warm up the engine until engine coolant is 80°C (176°F) or higher.

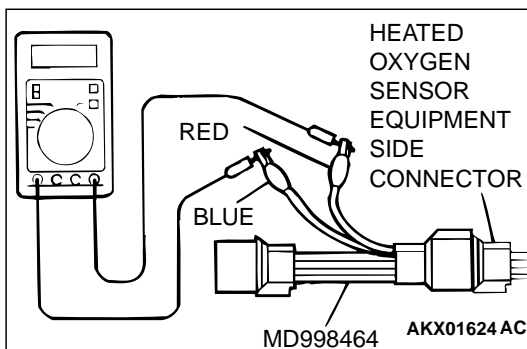

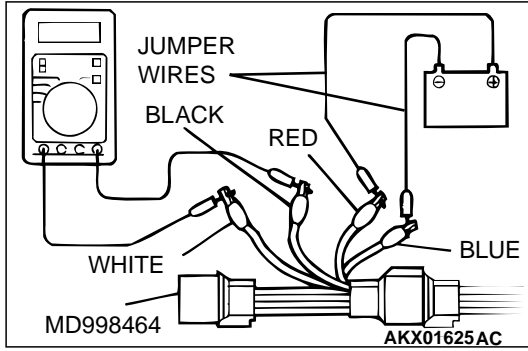

CAUTION

Be very careful when connecting the jumper wires; incorrect connection can damage the heated oxygen sensor.

- (5) Use the jumper wires to connect terminal 1 (red clip) of the heated oxygen sensor connector to the positive battery terminal and terminal 3 (blue clip) to the negative battery terminal.
 - (6) Connect a digital voltage meter between terminal 2 (black clip) and terminal 4 (white clip).
2. While repeatedly revving the engine, measure the heated oxygen sensor output voltage.

Standard value:

ENGINE	HEATED OXYGEN SENSOR OUTPUT VOLTAGE	REMARKS
When revving engine	0.6 – 1.0 volt	If you make the air/fuel ratio rich by revving the engine repeatedly, a normal heated oxygen sensor will output a voltage of 0.6 – 1.0 volt.

3. If the sensor is defective, replace the heated oxygen sensor.

NOTE: For removal and installation of the heated oxygen sensor, refer to GROUP 15, Exhaust Manifold P.15-7.

<Heated oxygen sensor (rear)>

1. Using scan tool MB991502, observe HO₂S reading. If values are unsatisfactory, or if Scan tool is not available, use the following procedure:
 - (1) Disconnect the heated oxygen sensor connector and connect special tool MB991658 to the connector on the heated oxygen sensor side.
 - (2) Make sure that there is continuity [11 – 18 Ω at 20°C (68°F)] between terminal 3 and terminal 4 on the heated oxygen sensor connector
 - (3) If there is no continuity, replace the heated oxygen sensor.
 - (4) Warm up the engine until engine coolant is 80°C (176°F) or higher.

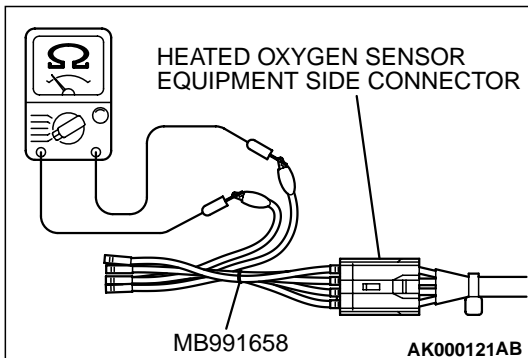

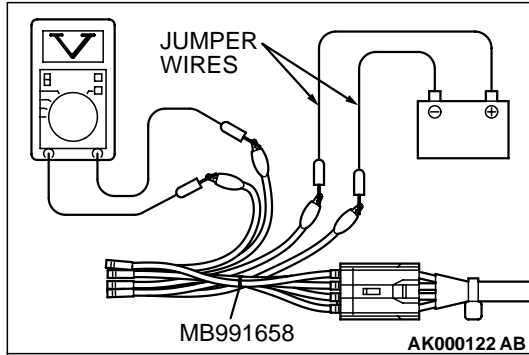

CAUTION

Be very careful when connecting the jumper wires; incorrect connection can damage the heated oxygen sensor.

- (5) Use the jumper wires to connect terminal 3 of the heated oxygen sensor connector to the positive battery terminal and terminal 4 to the negative battery terminal.
 - (6) Connect a digital voltage meter between terminal 1 and terminal 2.
2. While repeatedly revving the engine, measure the heated oxygen sensor output voltage.

Standard value:

ENGINE	HEATED OXYGEN SENSOR OUTPUT VOLTAGE	REMARKS
When revving engine	0.6 – 1.0 volt	If you make the air/fuel ratio rich by revving the engine repeatedly, a normal heated oxygen sensor will output a voltage of 0.6 – 1.0 volt.

3. If the sensor is defective, replace the heated oxygen sensor.
NOTE: For removal and installation of the heated oxygen sensor, refer to GROUP 15, Exhaust Pipe and Main Muffler P.15-9.

INJECTOR CHECK

M1131005200189

Measurement of Resistance between Terminals

1. Disconnect the injector connector.
2. Measure resistance between terminals.

Standard value: 13 – 16 Ω [at 20°C (68°F)]

3. If not within specification, replace the injector.
4. Install the injector connector

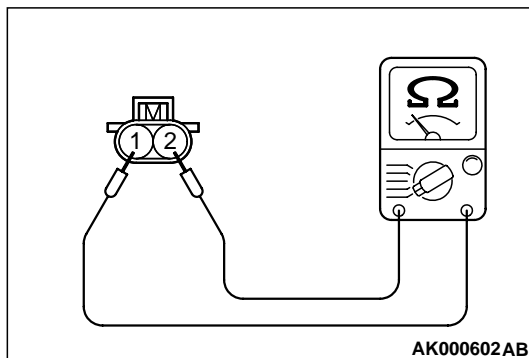

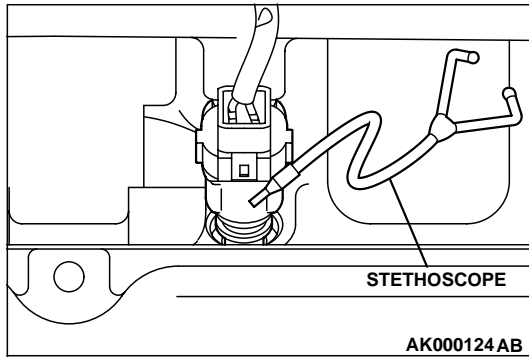
**Checking operation sound**

Using a stethoscope or long blade screwdriver, check the operation sound ("tick-tick-tick") of injectors during idling or during cranking. Check that as the engine speed increases, the frequency of the operating sound also increases.

1. If the injector you are checking is not operating, you may hear the operating sound of the other injectors.
2. If no operating sound is heard from the injector that is being checked, check the injector drive circuit. If there is nothing wrong with the circuit, a defective injector or engine control module (ECM) <M/T> or powertrain control module (PCM) <A/T> is suspected.

IDLE AIR CONTROL MOTOR (STEPPER MOTOR) CHECK

M1131005400075

Required Special Tool:

- MB991709: Test Harness Set

Checking the Operation Sound

1. Check that the engine coolant temperature is 20°C (68°F) or below.

NOTE: If necessary, you can disconnect the engine coolant temperature sensor connector and connect the harness-side of the connector to another engine coolant temperature sensor that is at 20°C (68°F) or below.

2. Check that the operation sound of the stepper motor can be heard after the ignition is switched ON (but do not start the engine).
3. If the operation sound cannot be heard, check the stepper motor's activation circuit. If the circuit is normal, it is probable that there is a malfunction of the stepper motor or engine control module (ECM) <M/T> or powertrain control module (PCM) <A/T>.

Checking the Coil Resistance

1. Disconnect the idle air control motor connector.

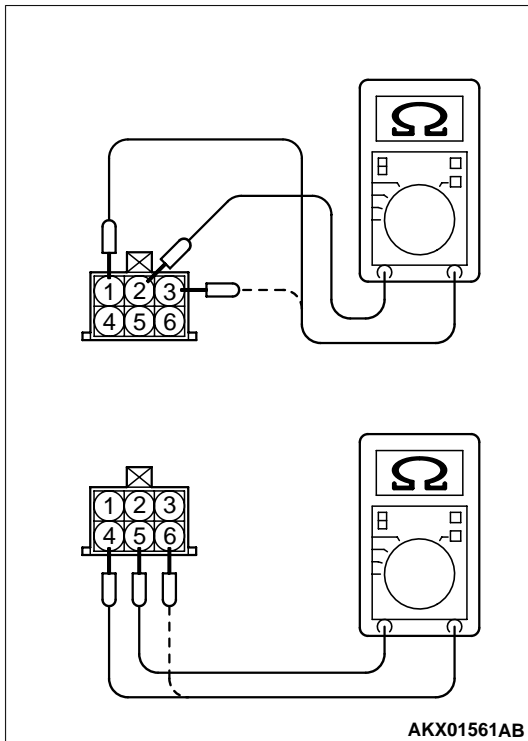

2. Measure resistance between terminal 2 and either terminal 1 or terminal 3 of the connector at the idle air control motor side.

Standard value: 28 – 33 Ω [at 20°C (68°F)]

3. If resistance is not within the standard value, replace the IAC motor.

4. Measure the resistance between terminal 5 and either terminal 6 or terminal 4 of the connector at the idle air control motor side.

Standard value: 28 – 33 Ω [at 20°C (68°F)]

5. If resistance is not within the standard value, replace the IAC motor.

<Operation Check>

1. Remove the throttle body.
2. Remove the idle air control motor.
3. Connect special tool MB991709 to the idle air control motor connector.

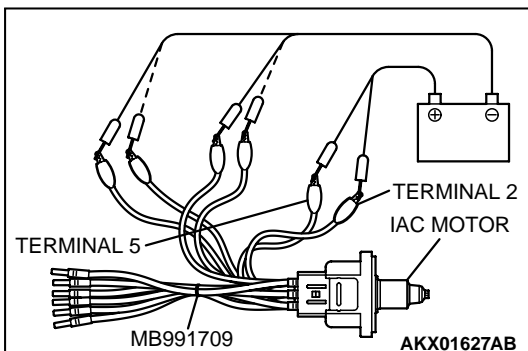

4. Connect the positive (+) terminal of a power supply (approximately 6 volts) to terminal 2 and the terminal 5.
5. Connect the negative (-) terminal of the power supply to each clip as described in the following steps. Then check whether or not the stepper motor vibrates slightly as it operates.

- (1) Connect the negative terminal of the power supply to terminal 1 and terminal 4.

- (2) Connect the negative terminal of the power supply to terminal 3 and terminal 4.

- (3) Connect the negative terminal of the power supply to terminal 3 and terminal 6.

- (4) Connect the negative terminal of the power supply to terminal 1 and terminal 6.

- (5) Connect the negative terminal of the power supply to terminal 1 and terminal 4.

- (6) Repeat the tests in sequence from (5) to (1) to test opposite movement of the IAC.

6. If vibration is detected during the test, the stepper motor can be considered to be normal.

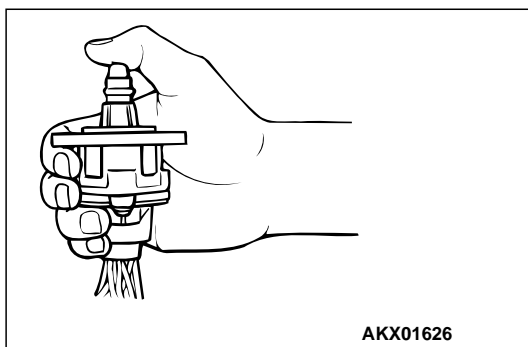

EVAPORATIVE EMISSION PURGE SOLENOID CHECK

M1131005600057

Refer to GROUP 17, Emission Control System – Evaporative Emission Control System – Evaporative Emission Purge Solenoid Check [P.17-114](#).

EGR SOLENOID CHECK

M1131005700054

Refer to GROUP 17, Emission Control System – Exhaust Gas Recirculation (EGR) System – EGR Solenoid Check [P.17-119](#).

EVAPORATIVE EMISSION VENTILATION SOLENOID CHECK

M1131012800031

Refer to GROUP 17, Emission Control System – Evaporative Emission Canister and Fuel Tank Pressure Relief Valve – Fuel Tank Pressure Relief Valve Inspection [P.17-120](#).

INJECTOR

REMOVAL AND INSTALLATION

M1131007100423

Pre-removal Operation

- Fuel Discharge Prevention (Refer to [P.13Aa-17](#).)

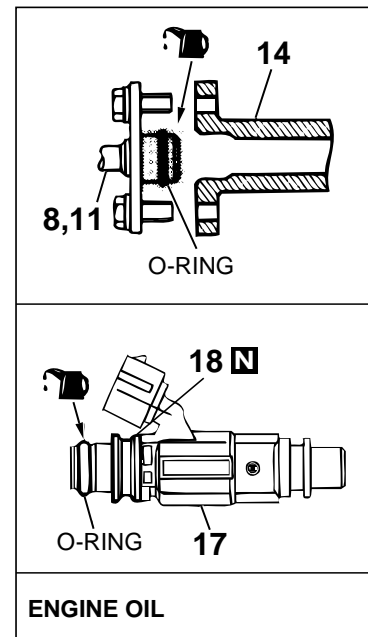
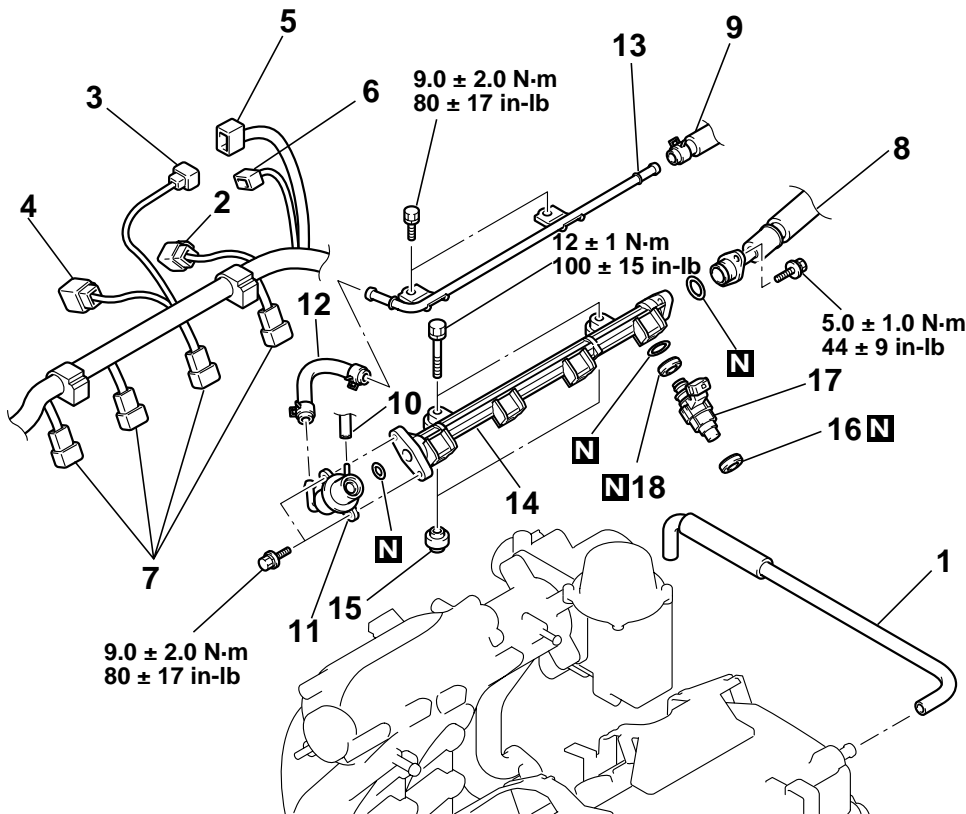

REMOVAL STEPS			REMOVAL STEPS (Continued)	
1.	PCV HOSE CONNECTION		>>A<<	8. HIGH-PRESSURE FUEL HOSE CONNECTION
2.	EGR SOLENOID VALVE CONNECTOR			9. FUEL RETURN HOSE CONNECTION
3.	MANIFOLD DIFFERENTIAL PRESSURESENSOR CONNECTOR		>>A<<	10. VACUUM HOSE CONNECTION
4.	PURGE CONTROL SOLENOID VALVE CONNECTOR			11. FUEL PRESSURE REGULATOR
5.	THROTTLE POSITION SENSOR CONNECTOR	<<A>>		12. FUEL HOSE
6.	IDLE AIR CONTROL MOTOR CONNECTOR	<<A>>	>>A<<	13. FUEL RETURN PIPE
7.	INJECTOR CONNECTOR			14. FUEL RAIL
				15. INSULATORS
				16. INSULATORS
				17. INJECTORS
				18. GROMMETS

REMOVAL SERVICE POINT

<<A>> FUEL RAIL/INJECTORS REMOVAL

CAUTION

Do not drop the injector.

Remove the fuel rail with the injectors attached to it.

INSTALLATION SERVICE POINT

>>A<< INJECTORS/FUEL PRESSURE REGULATOR/HIGH-PRESSURE FUEL HOSE INSTALLATION

CAUTION

Do not let the engine oil get into the fuel rail will be damaged.

1. Apply a drop of new engine oil to the O-ring.
2. Turn the injector. To the right and left to install to the fuel rail. Repeat for fuel pressure regulator and high-pressure fuel hose. Be careful not to damage the O-ring. After installing, check that the item turns smoothly.
3. If it dose not turn smoothly, the O-ring may be trapped, remove the item, re-install it into the fuel rail and check again.
4. Tighten the fuel pressure regulator and high-pressure fuel hose to the specified torque.

Tightening torque:

9.0 ± 2.0 N·m (80 ± 17 in-lb) <Fuel pressure regulator>

5.0 ± 1.0 N·m (44 ± 9 in-lb) <High-pressure fuel hose>

THROTTLE BODY ASSEMBLY

REMOVAL AND INSTALLATION

M1131007700395

Pre-removal Operation

- Engine Coolant Draining [Refer to GROUP 00, Maintenance Service – Engine Coolant (Change)P.00-45.]
- Air Cleaner Removal (Refer to GROUP 15, Air CleanerP.15-4.)

Post-installation Operation

- Air Cleaner Installation (Refer to GROUP 15, Air CleanerP.15-4.)
- Engine Coolant Refilling [Refer to GROUP 00, Maintenance Service – Engine Coolant (Change)P.00-45.]
- Accelerator Cable Adjustment (Refer to GROUP 17, On-vehicle Service – Accelerator Cable Check and AdjustmentP.17-4.)

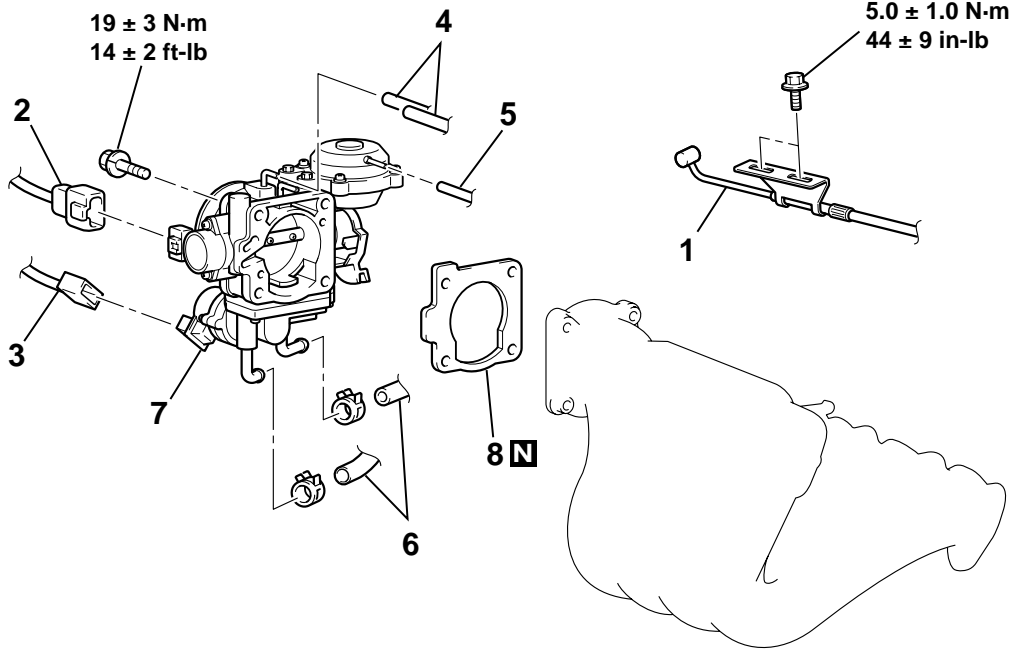

AC100464 AB

REMOVAL STEPS

1. ACCELERATOR CABLE CONNECTION
2. THROTTLE POSITION SENSOR CONNECTOR
3. IDLE AIR CONTROL MOTOR CONNECTOR
4. VACUUM HOSE CONNECTION

REMOVAL STEPS (Continued)

5. VACUUM HOSE CONNECTION <VEHICLES WITH AUTO-CRUISE CONTROL SYSTEM>
 6. WATER HOSE CONNECTION
 7. THROTTLE BODY
 8. THROTTLE BODY GASKET
- >>A<<

INSTALLATION SERVICE POINT

>>A<<THROTTLE BODY GASKET INSTALLATION

⚠ CAUTION

Poor idling etc. may result if the throttle body gasket is installed incorrectly.

Install the throttle body gasket as shown in the illustration.

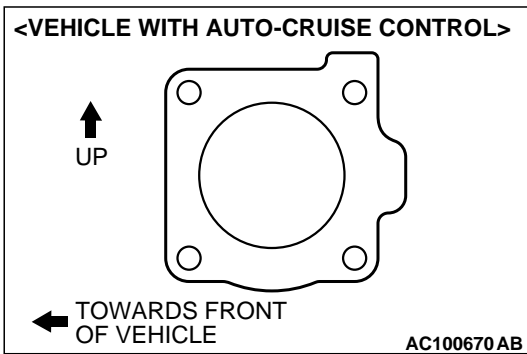
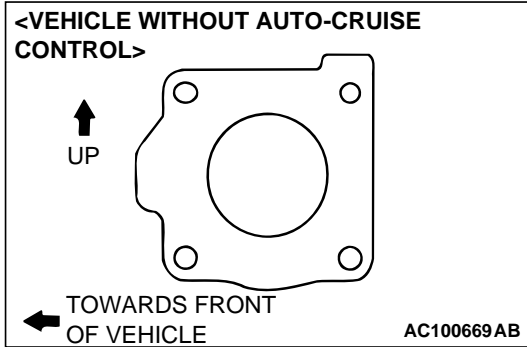

DISASSEMBLY AND ASSEMBLY

M1131009700346

<VEHICLES WITHOUT AUTO-CRUISE CONTROL SYSTEM>

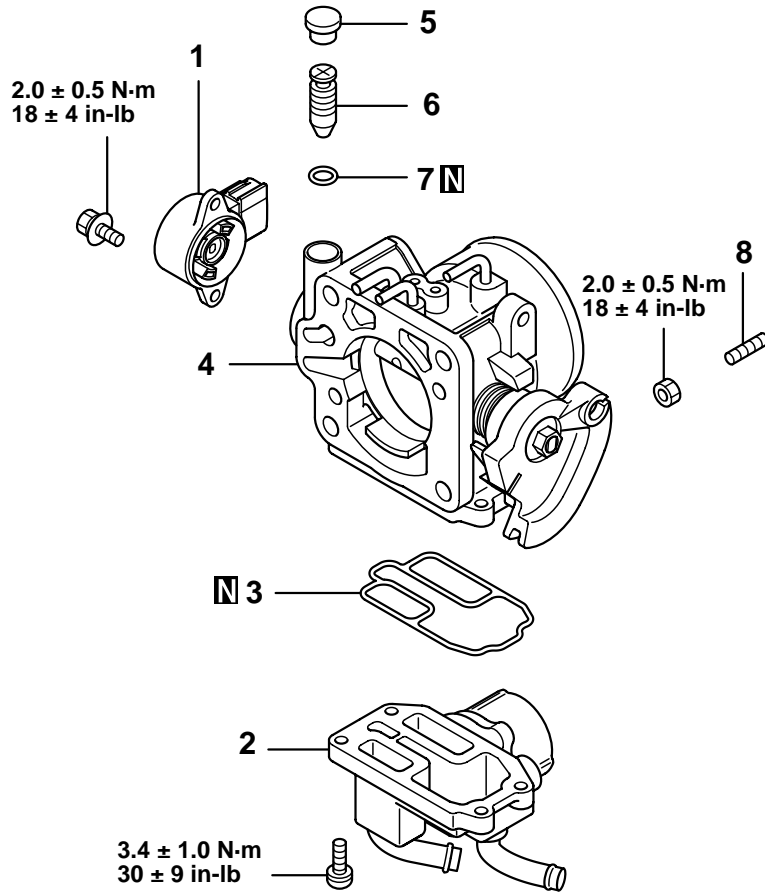

AK200501AB

- <<A>> >>A<<
- REMOVAL STEPS**
1. THROTTLE POSITION SENSOR
 2. FAST IDLE AIR VALVE
 3. GASKET
- <>
4. THROTTLE BODY
 5. CAP
 6. SPEED ADJUSTING SCREW

- REMOVAL STEPS (Continued)**
7. O-RING
 8. THROTTLE SPEED ADJUSTING SCREW

NOTE: IF THE ADJUSTING SCREW WAS HAPPEN TO HAVE BEEN REMOVED, PERFORM SPEED ADJUSTING SCREW ADJUSTMENT.

cardiagn.com

<VEHICLES WITH AUTO-CRUISE CONTROL SYSTEM>

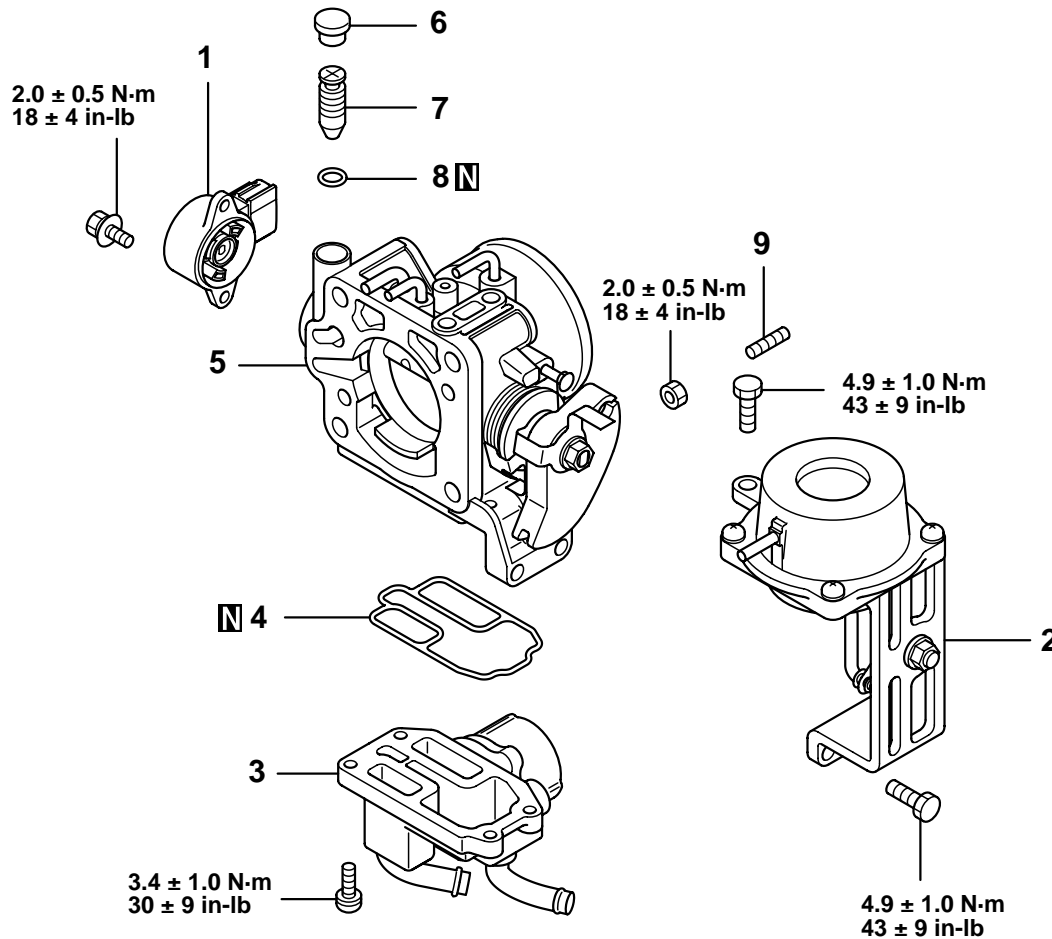

AK200502AB

- <<A>> >>A<<
- REMOVAL STEPS**
1. THROTTLE POSITION SENSOR
 2. LEVER ASSEMBLY
 3. FAST IDLE AIR VALVE
- <>
4. GASKET
 5. THROTTLE BODY
 6. CAP
 7. SPEED ADJUSTING SCREW

- REMOVAL STEPS (Continued)**
8. O-RING
 9. THROTTLE SPEED ADJUSTING SCREW

NOTE: IF THE ADJUSTING SCREW WAS HAPPEN TO HAVE BEEN REMOVED, PERFORM SPEED ADJUSTING SCREW ADJUSTMENT.

DISASSEMBLY SERVICE POINTS

<<A>> THROTTLE POSITION SENSOR DISASSEMBLY

1. Do not disassemble the sensor and motor.
2. Do not clean the sensor and motor by dipping them into cleaning solvent. Clean them with shop towel.

<> THROTTLE BODY DISASSEMBLY

1. Do not disassemble the throttle body.

2. Check if the vacuum port or passage is clogged. Use compressed air to clean the vacuum passage.

ASSEMBLY SERVICE POINTS

>>A<< THROTTLE POSITION SENSOR (TPS) INSTALLATION

1. Install the throttle position sensor to the throttle body as shown in the illustration.

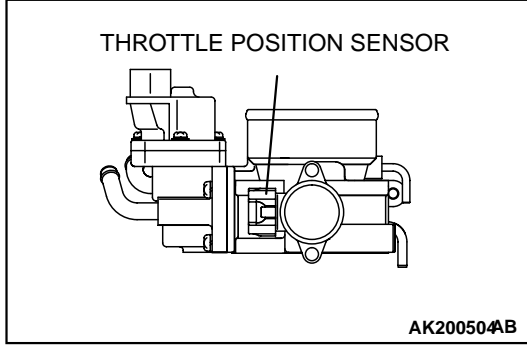

2. Turn the throttle position sensor 90 degrees clockwise to set it, and tighten the screws.

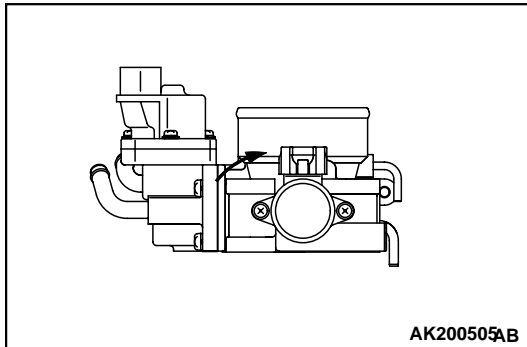

3. Connect an ohmmeter between terminals 2 (ground) and 1 (output), or between terminals 1 (output) and 3 (power). Then, make sure that the resistance changes smoothly when the throttle valve is slowly moved to the fully open position.

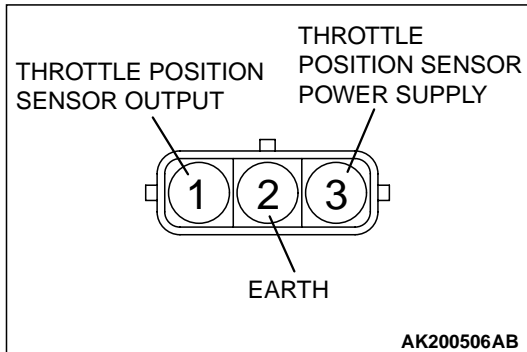

SPECIFICATIONS

FASTENER TIGHTENING SPECIFICATIONS

M1131011600410

ITEM	SPECIFICATION
Accelerator cable mounting bolts	5.0 ± 1.0 N·m (44 ± 9 in-lb)
Fuel pressure regulator	9.0 ± 2.0 N·m (80 ± 17 in-lb)
Fuel rail mounting bolt	12 ± 1 N·m (100 ± 15 in-lb)
High-pressure fuel hose	5.0 ± 1.0 N·m (44 ± 9 in-lb)
Idle air control motor	2.0 N·m (18 in-lb)

ITEM	SPECIFICATION
Lever assembly	4.9 N·m (44 in-lb)
Throttle body bracket M6	4.9 N·m (44 in-lb)
Throttle body bracket M8	6.9 N·m (61 in-lb)
Throttle body mounting bolt	19 ± 3 N·m (14 ± 2 ft-lb)
Throttle position sensor	2.0 N·m (18 in-lb)
Throttle speed adjusting screw mounting nut	2.0 N·m (18 in-lb)

GENERAL SPECIFICATIONS

M1131000200344

ITEMS		SPECIFICATIONS	
Throttle body	Throttle bore mm (in.)	55 (2.2)	
	Throttle position sensor	Variable resistor type	
	Idle air control motor	Stepper motor (stepper motor type bypass air control system)	
Engine control module (ECM) <M/T>	Identification model No.	Vehicles for federal emission regulation	E6T34976
		Vehicles for california emission regulation	E6T34975
Powertrain control module (PCM) <A/T>	Identification model No.	Vehicles for federal emission regulation	E6T31088 <Tire size: 185/65 R14> E6T31087 <Tire size: 195/60 R15>
		Vehicles for california emission regulation	E6T31086 <Tire size: 185/65 R14> E6T31085 <Tire size: 195/60 R15>
Sensors	Volume air flow sensor	Karman vortex type	
	Barometric pressure sensor	Semiconductor type	
	Intake air temperature sensor	Thermistor type	
	Engine coolant temperature sensor	Thermistor type	
	Heated oxygen sensor	Zirconia type	
	Vehicle speed sensor <M/T>	Electromagnetic resistance element type	
	Park/neutral position switch <A/T>	Contact switch type	
	Camshaft position sensor	Electromagnetic resistance element type	
	Crankshaft position sensor	Hall element type	
	Knock sensor	Piezoelectric type	
	Power steering pressure switch	Contact switch type	
	Manifold differential pressure sensor	Semiconductor type	

cardiagn.com

ITEMS		SPECIFICATIONS
Actuators	Multipoint fuel injection (MFI) relay	Contact switch type
	Fuel pump relay	Contact switch type
	Injector type and number	Electromagnetic type, 4
	Injector identification mark	CDH240
	EGR solenoid	Duty cycle type solenoid valve
	Evaporative emission purge solenoid	Duty cycle type solenoid valve
Fuel pressure regulator	Regulator pressure kPa (psi)	335 (47.6)

SERVICE SPECIFICATIONS

M1131000300169

ITEMS		STANDARD VALUE
Throttle position sensor adjusting voltage mV		335 – 935
Basic idle speed r/min		700 ± 50
Fuel pressure kPa (psi)	Vacuum hose disconnected	330 – 350 (47 – 50) at curb idle
	Vacuum hose connected	Approximately 270 (38) at curb idle
Intake air temperature sensor resistance kΩ	-20°C (-4°F)	13 – 17
	0°C (32°F)	5.3 – 6.7
	20°C (86°F)	2.3 – 3.0
	40°C (104°F)	1.0 – 1.5
	60°C (140°F)	0.56 – 0.76
	80°C (176°F)	0.30 – 0.42
Engine coolant temperature sensor resistance kΩ	-20°C (-4°F)	14 – 17
	0°C (32°F)	5.1 – 6.5
	20°C (86°F)	2.1 – 2.7
	40°C (104°F)	0.9 – 1.3
	60°C (140°F)	0.48 – 0.68
	80°C (176°F)	0.26 – 0.36
Throttle position sensor resistance kΩ		2.0 – 4.0
Heated oxygen sensor output voltage V		0.6 – 1.0
Heated oxygen sensor heater resistance Ω	<Front>	4.5 – 8.0
	<Rear>	11 – 18
Injector coil resistance Ω		13 – 16 [at 20°C (68°F)]
Idle air control motor coil resistance Ω		28 – 33 [at 20°C (68°F)]

SEALANT AND ADHESIVE

M1131000500022

ITEM	SPECIFIED SEALANT
Engine coolant temperature sensor threaded portion	3M™ AAD part number 8731 or equivalent